

Security Plus Online Uninterruptible Power Supply



GENERAL SAFETY INSTRUCTIONS

Warnings in this manual appear in any of four ways:



DANGER

Danger- The danger symbol is a lightning bolt mark enclosed in a triangle which precedes the 3/16-inch high letters spelling the word "DANGER". The danger symbol is used to indicate imminently hazardous situations, locations, and conditions which, if not avoided, WILL result in death, serious injury, and/or severe property damage.



CAUTION

Caution- The caution symbol is an exclamation mark enclosed in a triangle which precedes the 3/16-inch high letters spelling the word "CAUTION". The caution symbol is used to indicate potentially hazardous situations and conditions which, if not avoided may result in injury. Equipment damage may also occur.



WARNING

Warning- The warning symbol is an exclamation mark in a triangle which precedes the 3/16-inch high letters spelling the word "WARNING". The warning symbol is used to indicate potentially hazardous situations and conditions which, if not avoided COULD result in serious injury or death. Severe property damage COULD also occur.



ATTENTION

Attention warnings- The attention warning symbol is an exclamation mark enclosed in a triangle which precedes the 3/16-inch high letters spelling the word "ATTENTION". The Attention warning symbol is used to indicate situations and conditions that can cause operator injury and/or equipment damage.



Other warning symbols may appear along with the *Danger* and *Caution* symbol and are used to specify special hazards. These warnings describe particular areas where special care and/or procedures are required in order to prevent serious injury and possible death:

Electrical warnings- The electrical warning symbol is a lightning bolt mark enclosed in a triangle. The Electrical warning symbol is used to indicate high voltage locations and conditions may cause serious injury or death if the proper p



Explosion warnings- The explosion warning symbol is an explosion mark enclosed in a triangle. The Explosion warning symbol is used to indicate locations and conditions where molten, exploding parts may cause serious injury or death if the proper precautions are not observed

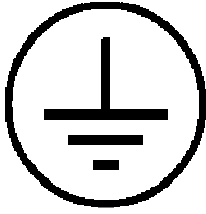

Protective earth (Ground)

N

Connection point for the neutral conductor on PERMANENTLY INSTALLED EQUIPMENT

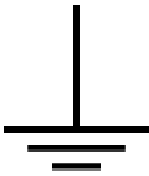

Earth Ground

NOTE TO USERS

To ensure correct operation of the UPS, please read this instruction manual carefully. Please keep this manual handy for future reference.

 <p>WARNING ELECTRICAL HAZARD AUTHORIZED PERSONNEL ONLY</p>	<p>This UPS has dangerously high voltages on both its Input and output connections. Contact with these voltages may be life threatening. Please follow the operating instructions carefully. Please give close attention to the warnings in this manual and those posted on the UPS. There are no user serviceable parts inside the UPS. Disassembly and/or maintenance should only be done by an authorized professional service technician.</p>
---	--

IMPORTANT INFORMATION FOR USERS OF THIS UNINTERRUPTIBLE POWER SUPPLY

1. Before operating the UPS or connecting any load equipment, please ensure the UPS is connected to a properly grounded electrical supply.
2. This UPS has dangerously high voltages on both its input and output connections. Contact with these voltages may be life threatening.
3. Please do not disassemble the covers. There is a risk of electric shock.
4. In an emergency, immediately turn off the circuit breaker for the circuit supplying power to the UPS. Also immediately turn off the battery circuit breaker.
5. This UPS has two power sources. One is the circuit supplying the UPS with input power. The other is the UPS battery. Prior to any maintenance, both of these power sources must be disconnected to ensure that the UPS is de-energized. If only the input power is disconnected, the UPS can still operate from the battery, and hazardous voltages may still exist.
6. To prevent damage or a safety hazard, keep the UPS away from open flame and any other devices that may cause sparks.
7. Do not open or damage individual battery cases as spillage of caustic electrolyte may occur resulting in danger to life, safety, and the environment.
8. The charging characteristics of UPS batteries vary by both brand and type. For this reason, replacement batteries should be of the same brand and type as those specified by the manufacturer. Using batteries other than the brand and type specified by the manufacturer may affect the performance of the UPS. Before installing batteries of different brand or type, please consult with the manufacturer.
9. The UPS has an internal EMI filter for purposes of enhancing electromagnetic compatibility with the input mains supply. This filter produces leakage current to earth on the input mains. When selecting a circuit breaker for the branch circuit supplying power to the UPS, ensure that the breaker selected is not an ELCB type circuit breaker that detects earth leakage current.
10. Please contact the manufacturer or an authorized distributor for any assistance with troubleshooting.

11. The UPS should only be serviced or maintained by a factory authorized service technician.
12. This UPS meets FCC Class A electromagnetic compatibility requirements.
13. Depleted batteries must be disposed of in a proper manner. Contact your local recycling or hazardous waste center or the UPS manufacturer for instructions concerning proper disposal.

CONTENTS

1.0 Overview	
1.1 Primary Functions and Operating Characteristics	7
1.2 Precautions	7
1.3 Performance Specifications	8
2.0 Structure and Basic Principles	
2.1 General Structure	30
2.1.1 Security Plus Front Panel and Rear Panel Structure.....	30
2.1.2 Security Plus Display/Controls Operation.....	31
2.1.3 Security Plus Terminal Connection Block Illustration (2-6kVA)	37
2.1.4 Security Plus Terminal Connection Block Illustration (8-15kVA)...	40
2.1.5 RS232 Communications	43
2.1.6 Communication Port Maintenance.....	43
2.2 Basic Principles	43
3.0 Equipment Installation	
3.1 Site and Environment Requirements.....	45
3.1.1 Site Requirements.....	45
3.1.2 Environment Requirements	45
3.2 Procedures of Dismantling Containers.....	45
3.3 Installation of UPS	48
4.0 Equipment Use and Maintenance	
4.1 Preparations for Start-up	49
4.2 Routine UPS Start-up Sequence.....	49
4.3 Routine UPS Shutdown	49
4.4 Important Battery Issues	49
4.5 Frequent Trouble Causes	50
4.6 Troubleshooting	52
4.6.1 Overview	52
4.6.2 Troubleshooting Steps	52
5.0 Battery Tray Replacement	
5.1 Precautions	54
5.1.1 Battery Tray Replacement (2-6kVA)	55
5.1.2 Battery Tray Replacement (2-6kVA)	56
5.1.3 Battery Tray Replacement (8-15kVA)	57
6.0 Packing, Transportation and Storage	
6.1 Packing.....	58
6.2 Transportation.....	58
6.3 Storage	58
6.4 Fuse Replacements	58
7.0 Mechanical Characteristics	
7.1 Unit Dimensions/Weights	59
7.2 Shipping Dimensions/Weights	59
8.0 Warranty	
8.1 Basic Warranty	60
8.2 Limitations.....	60

1.0 Overview

The Security Plus UPS is a high frequency, double conversion (true online) intelligent UPS for use with file servers, enterprise servers, microcomputers, telecommunication systems, data centers, laboratory instrumentation, and other microprocessor-based equipment that requires high quality, conditioned uninterruptible power. It is designed for use in telecom, IT, LAN, banking and financial, or almost any application where the performance of computer systems is mission critical. The Security Plus UPS is designed for connection to a single-phase alternating current input and provides power output loads requiring single-phase alternating current power.

1.1 Primary Functions and Operating Characteristics

1. Intelligent RS232 communication - Using the available RS232 standard data interface or USB port and UPS power management software, you take advantage of three communications functions: (1) The connected host computer can supervise UPS operation and control electric parameters, (2) Remote control of power ON and OFF functions can be accomplished, (3) with an available internal SNMP network adapter inserted in the internal card SNMP option card slot, the UPS is discoverable by a network.
2. High input power factor and low input THDI – This UPS uses an advanced active power factor correction (PFC) technology, which improves the input power factor and makes the UPS friendlier to the input mains supply.
3. High performance to price ratio – This UPS uses high frequency pulse width modulation (PWM) technology to ensure high efficiency, reduced size and weight, and improved operational reliability.
4. Dependable self-protection functions – This UPS provides dependable self-protection functions such as output over-voltage protection, battery low voltage protection, and input over-voltage protection. These self-protection features improve reliability and adaptability to a variety of electronic applications and installation environments.
5. Wide input voltage window – This UPS has a wide input voltage operating window, which ensures that even in the presence of unusually low or high input voltage, the UPS will continue to supply high quality dependable power to the connected load without discharging its battery. This reduces battery discharge cycles and results in increased battery life.

1.2 Precautions



Please be careful to observe the following general safety precautions during operation or maintenance

1. There are no user serviceable parts inside this UPS. Please don't remove the covers. This system can only be maintained or repaired by trained authorized service technicians.
2. To improve electromagnetic compatibility (EMC), this UPS has an input EMI filter, which produces potentially dangerous leakage current to ground. Ensure the UPS is connected to a properly grounded input electrical source.

3. Install this UPS indoors in an environment that is temperature and humidity controlled.
4. Install this UPS in a dust-free environment.
5. This UPS has two sources of power. Before maintenance is performed, turn off the branch circuit breaker powering the UPS and turn off all battery switches.
6. Even with the AC input power supply turned off, the UPS's internal battery still represents a potentially dangerous source of high voltage electrical power.
7. If the battery circuit has not been disconnected from the AC input, dangerous voltage potential still exists between the battery terminal and the ground terminal.
8. UPS batteries represent a high voltage source and a potential hazard to personal safety. Please pay attention to proper safety precautions and use insulated tools during installation.
9. UPS batteries contain corrosive and caustic chemicals. Improper handling of batteries may lead to the unintended release or leakage of these substances. Please handle batteries carefully.
10. Condensation may occur when the UPS is moved from a low temperature, low humidity environment to a warm humid environment. Condensation may cause UPS damage or hazardous electrical shock. To ensure the safety of both the UPS and the personnel around it, make sure that the UPS is installed only after it has fully acclimated to its installation environment. This UPS is not intended to be operated in an environment of either low temperature or high humidity.
11. DC voltage is still present on the battery fuses even with the UPS turned off. The battery trays must be removed before servicing UPS.

1.3 Performance Specifications

The major specifications of the Security Plus UPS are shown in the individual specification sheets on the following pages.

Note: Specifications are subject to change without notice.

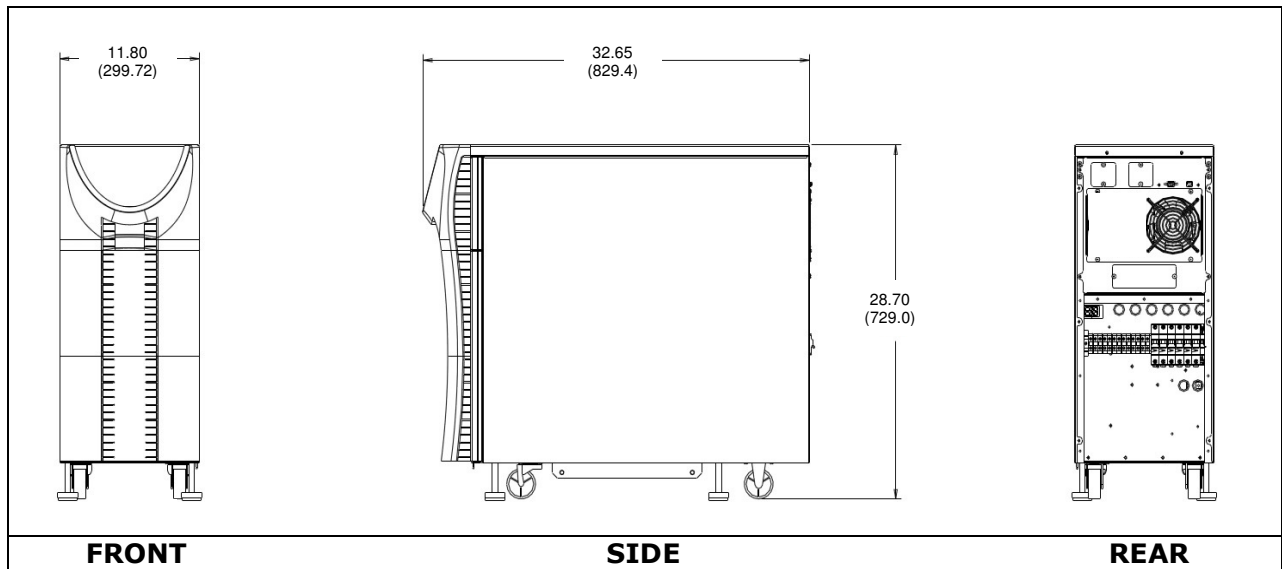

	Model	ABCDEF2000-11				ABCDEF2000-22			
	Topology	True On line, Double-Conversion, IGBT Design, Internal Isolation Transformer							
INPUT	Voltage (VAC)	100	115	120	200	208	220	230	240
	Voltage Range (VAC)	70-115	81-132	84-138	140-230	146-239	154-253	161-264	168-276
	Voltage Tolerance	+ 15% ~ -30% before switching to batteries							
	Frequency (Hz)	50/60							
	Frequency Tolerance	42 Hz to 69 Hz before switching to batteries							
	Input PF	> 0.95							
	Input Current THD	< 5.0%							
	Input Connection	Hardwired Standard; Line Cord Optional (Consult factory)							
Input Capacity	2160 VA				2160 VA				
OUTPUT	Capacity	2000VA/ 1800W							
	Voltage (VAC)	100	115	120	200	120 208 240	220	230	120 208 240
	Voltage Regulation	± 3.0% Max, ± 1.0% Normal							
	Output Voltage THD	< 3.0%							
	Power Factor	0.9							
	Step Load Response	± 4.0% for 50% step load change ± 6.0% for 100% step load change Return to ± 3.0% of nominal within 3 cycles							
	Crest Factor	3:1							
	Frequency (Hz)	50/60							
	Frequency Regulation	± 0.1Hz							
	Overload	125% for 2 minutes 150% for 30 seconds 300% for 500ms							
	Efficiency	AC-AC >85.0% DC-AC >71.0%				AC-AC >85.0% DC-AC >70.0%			
	Common Mode Noise	< 0.5 VRMS							
Output Connection	Hardwired Standard; Output Receptacles Optional (Consult factory)								
BYPASS	Input Voltage (VAC)	100	115	120	200	208	220	230	240
	Output Voltage (VAC)	100	115	120	200	120 208 240	220	230	120 208 240
	Transformer Voltage Regulation	± 3.0%							
	Overload	125% for 10 minutes 150% for 500ms 1000% for 1 cycle							
	Efficiency	> 95.0%							

BATTERY	Voltage (VDC)	96.0, nominal 109.2, float
	Battery	12V, 34W flame retardant High Rate, Sealed Lead-Acid
	Quantity	8
	Charge Current (ADC)	2.0
	Backup Time (min)	> 7.0
	Recharge Time	8 hours to 90%
ENVIRONMENT	Temperature (°C)	0 to 40, operating -20 to 60, transit
	Altitude (m)	2,000, operating 12,000, transit
	Humidity	5.0% to 90.0%, non condensing
	Audible (dBA)	50-55 @ 1m from front of unit
	Heat Dissipation (BTU/hr)	1084
AGENCIES	EMC	FCC Part 15J Class A EN 55022 Class A/ CISPR 22 EN 50091-2 IEC 61000-3-2
	Safety Agencies	UL1778 4 th Ed. cUL to CSA22.2 No.107.1 CE (-22 only): IEC62040, w/CB report and cert IEC62040, w/CB report and cert IEC61000-4-2, Electrostatic Discharge IEC61000-4-3, Radiated Electromagnetic Field Immunity IEC61000-4-4, Electrical Fast Transient/ Burst Immunity IEC61000-4-5, Surge Immunity IEC61000-4-6, Immunity to Conducted Radio Frequency Disturbances IEC61000-4-8, Power Frequency Magnetic Field Immunity IEC61000-4-11, Voltage Dips, Short Interruptions, and Voltage Variations
	RoHS	All units are RoHS compliant
OTHER	Communication	RS-232 USB DB-9 Dry Contacts Internal SNMP Adapter (option)
	Unit Weight	-11 Models 215 lbs. / 97 kg. -22 Models 221 lbs. / 100 kg.
	Shipping Weight	-11 Models 310 lbs. / 139 kg. -22 Models 316 lbs. / 142 kg.
	Plug & Receptacle*	L5-30P (2)5-20R (1)L5-30R 208 VAC Input L6-30P (2)5-20R (1)L6-30R 240 VAC Input L6-20P (2)5-20R (1)L6-20R

*Hardwired unit is standard. Plug & Receptacle is optional. Contact factory for part numbers.

NOISE REJECTION-ISOLATION: With unit under power and an ANSI/IEEE C62.41Cat. A pulse applied either normal or common mode at the input, the noise output voltage will be less than 10V normal mode and less than 0.5V common mode in all four quadrants (CM-NM, NM-NM, CM-CM, NM-CM).

SURGE VOLTAGE WITHSTAND CAPABILITY: Tested under power to ANSI/IEEE C62.41 Cat. A & B (formerly IEEE587-1980). Cat. A - 6000V @ 200 amps, 0.5 usec risetime, 100 kHz decay, Cat. B - 6000V @ 500 amps, 0.5 usec risetime, 100 kHz decay.

ABCDEF2000-11 Compatible External (Extended Run) Battery Cabinets:

Model: D9632-11 Description: 4 Pack (32 Batt) Extended Run Battery Cabinet

Model: D9648-11 Description: 6 Pack (48 Batt) Extended Run Battery Cabinet

ABCDEF2000-11 TYPICAL RUN-TIMES (MINs)				
	25% (450 W)	50% (900 W)	75% (1350 W)	100% (1800 W)
Internal Batteries Only	20	13	10	7
Internal + 1) D9632-11	170	110	80	65
Internal + 2) D9632-11	375	250	190	140
Internal + 3) D9632-11	625	400	300	225
Internal + 4) D9632-11	>12 Hrs	575	400	300
Internal + 5) D9632-11	>12 Hrs	>12 Hrs	575	450
Internal + 1) D9648-11	250	180	130	100
Internal + 2) D9648-11	625	400	300	230
Internal + 3) D9648-11	>12 Hrs	700	500	375
Internal + 4) D9648-11	>12 Hrs	>12 Hrs	>12 Hrs	575
Internal + 5) D9648-11	>12 Hrs	>12 Hrs	>12 Hrs	>12 Hrs

Note: Run-Times are based on new fully charged batteries at 25 deg C ambient.

ABCDEF2000-22 Compatible External (Extended Run) Battery Cabinets:

Model: D9632-22 Description: 4 Pack (32 Batt) Extended Run Battery Cabinet

Model: D9648-22 Description: 6 Pack (48 Batt) Extended Run Battery Cabinet

ABCDEF2000-22 TYPICAL RUN-TIMES (MINs)				
	25% (450 W)	50% (900 W)	75% (1350 W)	100% (1800 W)
Internal Batteries Only	18	12	9	7
Internal + 1) D9632-22	160	110	80	65
Internal + 2) D9632-22	325	230	180	140
Internal + 3) D9632-22	575	375	275	225
Internal + 4) D9632-22	>12 Hrs	575	425	325
Internal + 5) D9632-22	>12 Hrs	>12 Hrs	550	425
Internal + 1) D9648-22	240	170	130	100
Internal + 2) D9648-22	575	375	275	225
Internal + 3) D9648-22	>12 Hrs	650	475	375
Internal + 4) D9648-22	>12 Hrs	>12 Hrs	>12 Hrs	550
Internal + 5) D9648-22	>12 Hrs	>12 Hrs	>12 Hrs	>12 Hrs

Note: Run-Times are based on new fully charged batteries at 25 deg C ambient.

Battery Life Disclaimer: Powervar's standard battery warranty applies only to UPS and UPM products which are continuously connected to AC mains power, except during utility power outages. Products which are regularly and intentionally disconnected from AC mains power will experience battery discharge/charge cycles potentially far more numerous than those for which the battery was designed. As a result, products used in such applications will experience substantially reduced battery life. For that reason, Powervar's standard battery warranty does not apply for applications in which the UPS or UPM product is regularly and intentionally disconnected from AC mains power. Powervar UPS and UPM products used in such applications shall receive a 90 day warranty on batteries.

Warranty/Support: Powervar warrants the electronics and transformers used in its uninterruptible power supplies to be free from defects in materials and workmanship for a period of three years from the date of shipment. Batteries are warranted for a period of two years from the date of shipment for standby use; 90 days for cyclic use. For North American service or support on any Powervar product, please contact Powervar Technical Support at (800) 369-7179 (in Illinois call (847-596-7000)). For service and support in EMEA, contact Powervar, Ltd. in the United Kingdom at +44 (0) 1793 553980. Or visit the Powervar website at www.Powervar.com.

Powervar, Inc. - 1450 Lakeside Drive, Waukegan, IL 60085

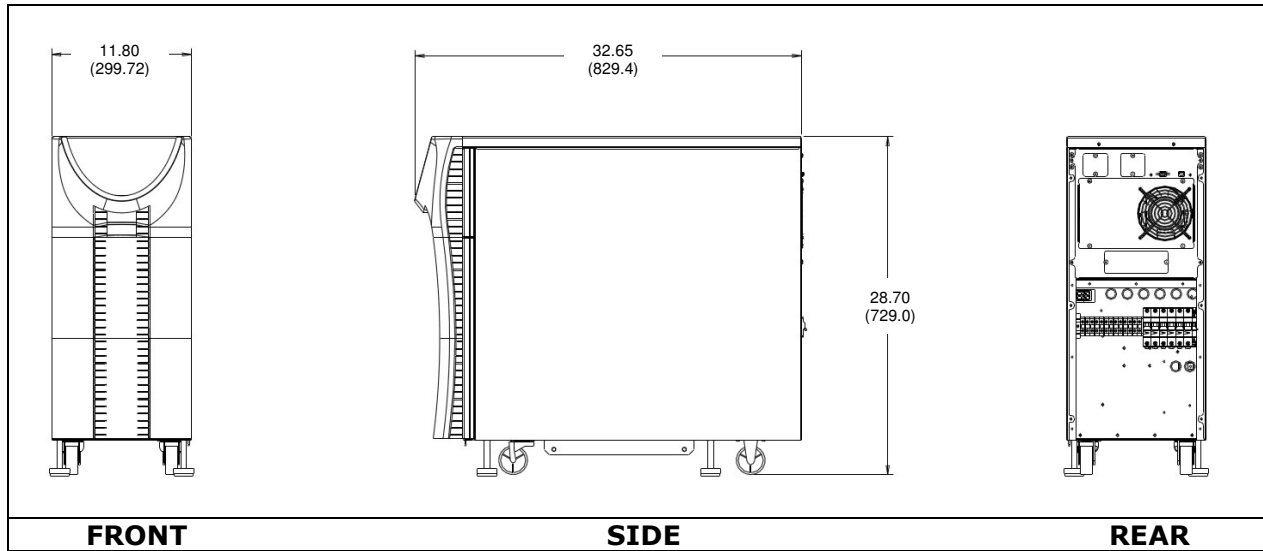

	Model	ABCDEF3000-11				ABCDEF3000-22			
	Topology	True On-line, Double-Conversion, IGBT Design, Internal Isolation Transformer							
INPUT	Voltage (VAC)	100	115	120	200	208	220	230	240
	Voltage Range (VAC)	70-115	81-132	84-138	140-230	146-239	154-253	161-264	168-276
	Voltage Tolerance	+ 15% ~ -30% before switching to batteries							
	Frequency (Hz)	50/60							
	Frequency Tolerance	42 Hz to 69 Hz before switching to batteries							
	Input PF	> 0.95							
	Input Current THD	< 5.0%							
	Input Connection	Hardwired Standard; Line Cord Optional (Consult factory)							
Input Capacity	3240 VA				3240 VA				
OUTPUT	Capacity	3000VA/ 2700W							
	Voltage (VAC)	100	115	120	200	120 208 240	220	230	120 208 240
	Voltage Regulation	± 3.0% Max, ± 1.0% Normal							
	Output Voltage THD	< 3.0%							
	Power Factor	0.9							
	Step Load Response	± 4.0% for 50% step load change ± 6.0% for 100% step load change Return to ±3.0% of nominal within 3 cycles							
	Crest Factor	3:1							
	Frequency (Hz)	50/60							
	Frequency Regulation	± 0.1Hz							
	Overload	125% for 2 minutes 150% for 30 seconds 300% for 500ms							
	Efficiency	AC-AC >85.0% DC-AC >77.0%				AC-AC >85.0% DC-AC >76.0%			
	Common Mode Noise	< 0.5 VRMS							
Output Connection	Hardwired Standard; Output Receptacles Optional (Consult factory)								
BYPASS	Input Voltage (VAC)	100	115	120	200	208	220	230	240
	Output Voltage (VAC)	100	115	120	200	120 208 240	220	230	120 208 240
	Transformer Voltage Regulation	± 3.0%							
	Overload	125% for 10 minutes 150% for 500ms 1000% for 1 cycle							
	Efficiency	> 95.0%							

BATTERY	Voltage (VDC)	96.0, nominal 109.2, float
	Battery	12V, 34W flame retardant High Rate, Sealed Lead-Acid
	Quantity	16
	Charge Current (ADC)	3.0
	Backup Time (min)	> 12.0
	Recharge Time	8 Hours to 90%
ENVIRONMENT	Temperature (°C)	0 to 40, operating -20 to 60, transit
	Altitude (m)	2,000, operating 12,000, transit
	Humidity	5.0% to 90.0%, non condensing
	Audible (dBA)	50-55 @ 1m from front of unit
	Heat Dissipation (BTU/hr)	1626
AGENCIES	EMC	FCC Part 15J Class A EN 55022 Class A/ CISPR 22 EN 50091-2 IEC 61000-3-2
	Safety Agencies	UL1778 4 th Ed. cUL to CSA22.2 No.107.1 CE (-22 only): IEC62040, w/CB report and cert IEC61000-4-2, Electrostatic Discharge IEC61000-4-3, Radiated Electromagnetic Field Immunity IEC61000-4-4, Electrical Fast Transient/ Burst Immunity IEC61000-4-5, Surge Immunity IEC61000-4-6, Immunity to Conducted Radio Frequency Disturbances IEC61000-4-8, Power Frequency Magnetic Field Immunity IEC61000-4-11, Voltage Dips, Short Interruptions, and Voltage Variations
	RoHS	All units are RoHS compliant
OTHER	Communication	RS-232 USB DB-9 Dry Contacts Internal SNMP Adapter (option)
	Unit Weight	-11 Models 294 lbs. / 132 kg. -22 Models 300 lbs. / 135 kg.
	Shipping Weight	-11 Models 389 lbs. / 175 kg. -22 Models 395 lbs. / 178 kg.
	Plug & Receptacle*	L5-30P (2)5-20R (1)L5-30R 208 VAC Input L6-30P (2)5-20R (1)L6-30R 240 VAC Input L6-20P (2)5-20R (1)L6-20R

*Hardwired unit is standard. Plug & Receptacle is optional. Contact factory for part numbers.

NOISE REJECTION-ISOLATION: With unit under power and an ANSI/IEEE C62.41 Cat. A pulse applied either normal or common mode at the input, the noise output voltage will be less than 10V normal mode and less than 0.5V common mode in all four quadrants (CM-NM, NM-NM, CM-CM, NM-CM).

SURGE VOLTAGE WITHSTAND CAPABILITY: Tested under power to ANSI/IEEE C62.41 Cat. A & B (formerly IEEE587-1980). Cat. A - 6000V @ 200 amps, 0.5 usec risetime, 100 kHz decay, Cat. B - 6000V @ 500 amps, 0.5 usec risetime, 100 kHz decay.

ABCDEF3000-11 Compatible External (Extended Run) Battery Cabinets:

Model: D9632-11 Description: 4 Pack (32 Batt) Extended Run Battery Cabinet

Model: D9648-11 Description: 6 Pack (48 Batt) Extended Run Battery Cabinet

ABCDEF3000-11 TYPICAL RUN-TIMES (MINs)				
	25% (675 W)	50% (1350 W)	75% (2025 W)	100% (2700 W)
Internal Batteries Only	40	24	17	12
Internal + 1) D9632-11	170	100	70	55
Internal + 2) D9632-11	325	200	140	110
Internal + 3) D9632-11	550	325	225	170
Internal + 4) D9632-11	>12 Hrs	450	310	230
Internal + 5) D9632-11	>12 Hrs	600	400	300
Internal + 1) D9648-11	250	150	100	80
Internal + 2) D9648-11	550	325	220	160
Internal + 3) D9648-11	>12 Hrs	525	350	250
Internal + 4) D9648-11	>12 Hrs	>12 Hrs	525	375
Internal + 5) D9648-11	>12 Hrs	>12 Hrs	700	525

Notes: Run-Times are based on new fully charged batteries at 25 deg C ambient.

ABCDEF3000-22 Compatible External (Extended Run) Battery Cabinets:

Model: D9632-22 Description: 4 Pack (32 Batt) Extended Run Battery Cabinet

Model: D9648-22 Description: 6 Pack (48 Batt) Extended Run Battery Cabinet

ABCDEF3000-22 TYPICAL RUN-TIMES (MINs)				
	25% (675 W)	50% (1350 W)	75% (2025 W)	100% (2700 W)
Internal Batteries Only	35	23	15	12
Internal + 1) D9632-22	160	100	70	55
Internal + 2) D9632-22	325	200	140	110
Internal + 3) D9632-22	500	300	210	165
Internal + 4) D9632-22	>12 Hrs	425	300	230
Internal + 5) D9632-22	>12 Hrs	575	400	300
Internal + 1) D9648-22	230	150	100	80
Internal + 2) D9648-22	500	300	210	160
Internal + 3) D9648-22	>12 Hrs	500	350	270
Internal + 4) D9648-22	>12 Hrs	>12 Hrs	525	375
Internal + 5) D9648-22	>12 Hrs	>12 Hrs	675	500

Notes: Run-Times are based on new fully charged batteries at 25 deg C ambient.

Battery Life Disclaimer: Powervar's standard battery warranty applies only to UPS and UPM products which are continuously connected to AC mains power, except during utility power outages. Products which are regularly and intentionally disconnected from AC mains power will experience battery discharge/charge cycles potentially far more numerous than those for which the battery was designed. As a result, products used in such applications will experience substantially reduced battery life. For that reason, Powervar's standard battery warranty does not apply for applications in which the UPS or UPM product is regularly and intentionally disconnected from AC mains power. Powervar UPS and UPM products used in such applications shall receive a 90 day warranty on batteries.

Warranty/Support: Powervar warrants the electronics and transformers used in its uninterruptible power supplies to be free from defects in materials and workmanship for a period of three years from the date of shipment. Batteries are warranted for a period of two years from the date of shipment for standby use; 90 days for cyclic use. For North American service or support on any Powervar product, please contact Powervar Technical Support at (800) 369-7179 (in Illinois call (847-596-7000). For service and support in EMEA, contact Powervar, Ltd. in the United Kingdom at +44 (0) 1793 553980. Or visit the Powervar website at www.Powervar.com.

Powervar, Inc. - 1450 Lakeside Drive, Waukegan, IL 60085

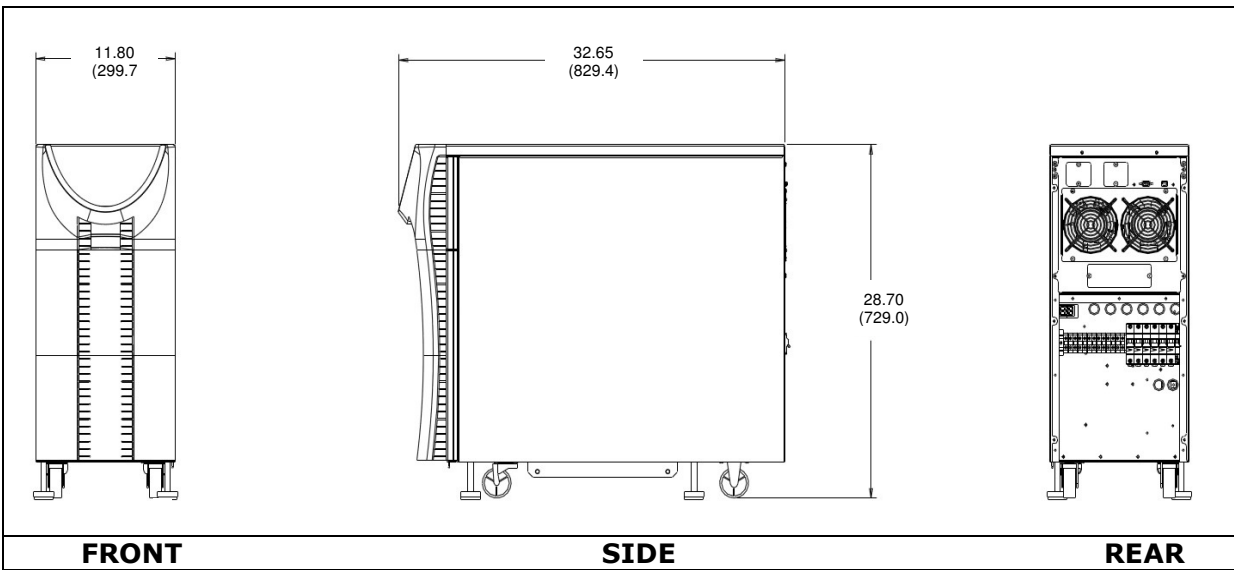

	Model	ABCDEF4000-22				
	Topology	True On-Line, Double-Conversion, IGBT Design, Internal Isolation Transformer				
INPUT	Voltage (VAC)	200	208	220	230	240
	Voltage Range (VAC)	140-230	146-239	154-253	161-264	168-276
	Voltage Tolerance	+ 15% ~ -30% before switching to batteries				
	Frequency (Hz)	50/60				
	Frequency Tolerance	42 Hz to 69 Hz before switching to batteries				
	Input PF	> 0.95				
	Input Current THD	< 5.0%				
	Input Connection	Hardwired Standard; Line Cord Optional (Consult factory)				
Input Capacity	4320 VA					
OUTPUT	Capacity	4000VA/ 3600W				
	Voltage (VAC)	200	120/208/240	220	230	120/208/240
	Voltage Regulation	± 3.0% Max, ± 1.0% Normal				
	Output Voltage THD	< 3.0%				
	Power Factor	0.9				
	Step Load Response	± 4.0% for 50% step load change ± 6.0% for 100% step load change Return to ±3.0% of nominal within 3 cycles				
	Crest Factor	3:1				
	Frequency (Hz)	50/60				
	Frequency Regulation	± 0.1Hz				
	Overload	125% for 2 minutes 150% for 30 seconds 300% for 500ms				
	Efficiency	AC-AC >85.0% DC-AC >78.0%				
	Common Mode Noise	< 0.5 VRMS				
Output Connection	Hardwired Standard; Output Receptacles Optional (Consult factory)					
BYPASS	Input Voltage (VAC)	200	208	220	230	240
	Output Voltage (VAC)	200	120/208/240	220	230	120/208/240
	Transformer Voltage Regulation	± 3.0%				
	Overload	125% for 10 minutes 150% for 500ms 1000% for 1 cycle				
	Efficiency	> 95.0%				

BATTERY	Voltage (VDC)	96.0, nominal 109.2, float
	Battery	12V, 34W flame retardant High Rate, Sealed Lead-Acid
	Quantity	16
	Charge Current (ADC)	3.0
	Backup Time (min)	> 8.0
	Recharge Time	8 Hours to 90%
ENVIRONMENT	Temperature (°C)	0 to 40, operating -20 to 60, transit
	Altitude (m)	2,000, operating 12,000, transit
	Humidity	5.0% to 90.0%, non condensing
	Audible (dBA)	50-55 @ 1m from front of unit
	Heat Dissipation (BTU/hr)	3252
AGENCIES	EMC	FCC Part 15J Class A EN 55022 Class A/ CISPR 22 EN 50091-2 IEC 61000-3-2
	Safety Agencies	UL1778 4 th Ed. cUL to CSA22.2 No.107.1 CE: IEC62040, w/CB report and certificate IEC61000-4-2, Electrostatic Discharge IEC61000-4-3, Radiated Electromagnetic Field Immunity IEC61000-4-4, Electrical Fast Transient/ Burst Immunity IEC61000-4-5, Surge Immunity IEC61000-4-6, Immunity to Conducted Radio Frequency Disturbances IEC61000-4-8, Power Frequency Magnetic Field Immunity IEC61000-4-11, Voltage Dips, Short Interruptions, and Voltage Variations
	RoHS	All units are RoHS compliant
OTHER	Communication	RS-232 USB DB-9 Dry Contacts Internal SNMP Adapter (option)
	Unit Weight	317 lbs. / 143 kg.
	Shipping Weight	412 lbs. / 185 kg.
	Plug & Receptacle*	L6-30P (2)5-20R (1)L6-30R

*Hardwire unit is standard. Plug & Receptacle is optional. Contact factory for part numbers.

NOISE REJECTION-ISOLATION: With unit under power and an ANSI/IEEE C62.41Cat. A pulse applied either normal or common mode at the input, the noise output voltage will be less than 10V normal mode and less than 0.5V common mode in all four quadrants (CM-NM, NM-NM, CM-CM, NM-CM).

SURGE VOLTAGE WITHSTAND CAPABILITY: Tested under power to ANSI/IEEE C62.41 Cat. A & B (formerly IEEE587-1980). Cat. A - 6000V @ 200 amps, 0.5 usec risetime, 100 kHz decay, Cat. B - 6000V @ 500 amps, 0.5 usec risetime, 100 kHz decay.

Compatible External (Extended Run) Battery Cabinets:

Model: D9632-22 Description: 4 Pack (32 Batt) Extended Run Battery Cabinet

Model: D9648-22 Description: 6 Pack (48 Batt) Extended Run Battery Cabinet

ABCDEF4000-22 TYPICAL RUN-TIMES (MINs)				
	25% (900 W)	50% (1800 W)	75% (2700 W)	100% (3600 W)
Internal Batteries Only	25	17	11	8
Internal + 1) D9632-22	120	75	50	35
Internal + 2) D9632-22	250	150	100	75
Internal + 3) D9632-22	375	220	150	110
Internal + 4) D9632-22	550	325	210	160
Internal + 5) D9632-22	>12 Hrs	425	275	210
Internal + 1) D9648-22	170	110	75	55
Internal + 2) D9648-22	375	220	150	120
Internal + 3) D9648-22	625	375	250	185
Internal + 4) D9648-22	>12 Hrs	525	350	275
Internal + 5) D9648-22	>12 Hrs	>12 Hrs	475	350

Notes: Run-Times are based on new fully charged batteries at 25 deg C ambient.

Battery Life Disclaimer: Powervar's standard battery warranty applies only to UPS and UPM products which are continuously connected to AC mains power, except during utility power outages. Products which are regularly and intentionally disconnected from AC mains power will experience battery discharge/charge cycles potentially far more numerous than those for which the battery was designed. As a result, products used in such applications will experience substantially reduced battery life. For that reason, Powervar's standard battery warranty does not apply for applications in which the UPS or UPM product is regularly and intentionally disconnected from AC mains power. Powervar UPS and UPM products used in such applications shall receive a 90 day warranty on batteries.

Warranty/Support: Powervar warrants the electronics and transformers used in its uninterruptible power supplies to be free from defects in materials and workmanship for a period of three years from the date of shipment. Batteries are warranted for a period of two years from the date of shipment for standby use; 90 days for cyclic use. For North American service or support on any Powervar product, please contact Powervar Technical Support at (800) 369-7179 (in Illinois call (847-596-7000)). For service and support in EMEA, contact Powervar, Ltd. in the United Kingdom at +44 (0) 1793 553980. Or visit the Powervar website at www.Powervar.com.

Powervar, Inc. - 1450 Lakeside Drive, Waukegan, IL 60085

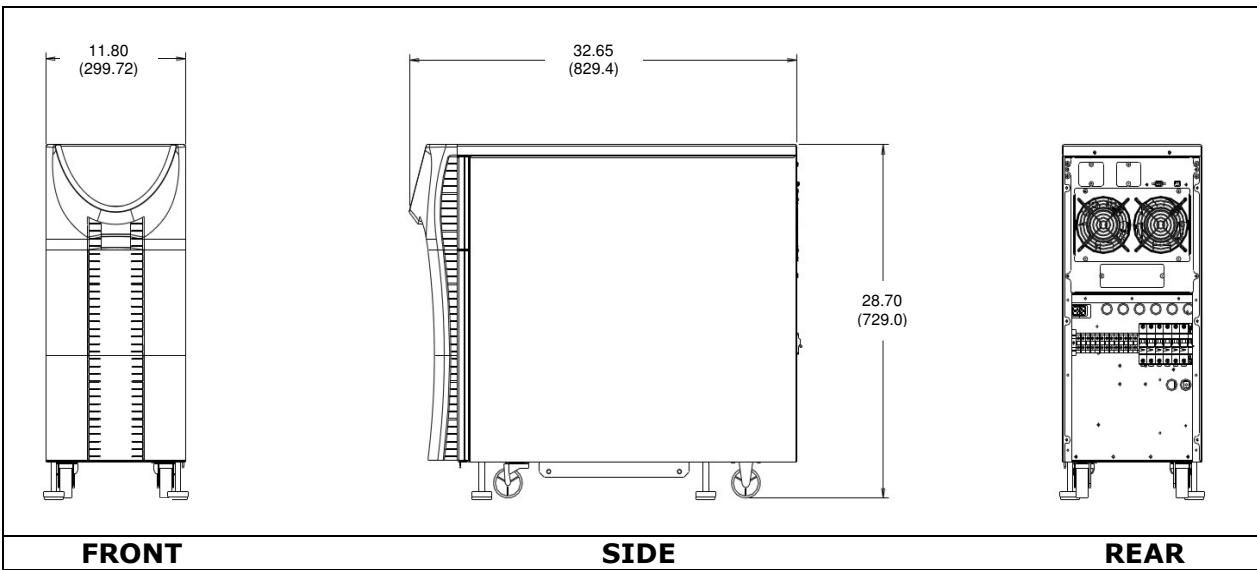

	Model	ABCDEF5200-22				
	Topology	True On-Line, Double-Conversion, IGBT Design, Internal Isolation Transformer				
INPUT	Voltage (VAC)	200	208	220	230	240
	Voltage Range (VAC)	140-230	146-239	154-253	161-264	168-276
	Voltage Tolerance	+ 15% ~ -30% before switching to batteries				
	Frequency (Hz)	50/60				
	Frequency Tolerance	42 Hz to 69 Hz before switching to batteries				
	Input PF	> 0.95				
	Input Current THD	< 5.0%				
	Input Connection	Hardwired Standard: Line cord Optional (Consult factory)				
Input Capacity	5616 VA					
OUTPUT	Capacity	5200VA/ 4680W				
	Voltage (VAC)	200	120/208/240	220	230	120/208/240
	Voltage Regulation	± 3.0% Max, ± 1.0% Normal				
	Output Voltage THD	< 3.0%				
	Power Factor	0.9				
	Step Load Response	± 4.0% for 50% step load change ± 6.0% for 100% step load change Return to ±3.0% of nominal within 3 cycles				
	Crest Factor	3:1				
	Frequency (Hz)	50/60				
	Frequency Regulation	± 0.1Hz				
	Overload	125% for 2 minutes 150% for 30 seconds 300% for 500ms				
	Efficiency	AC-AC >85.0% DC-AC >76.0%				
Common Mode Noise	< 0.5 VRMS					
Output Connection	Hardwired Standard; Output Receptacles Optional (Consult factory)					
BYPASS	Input Voltage (VAC)	200	208	220	230	240
	Output Voltage (VAC)	200	120/208/240	220	230	120/208/240
	Transformer Voltage Regulation	± 3.0%				
	Overload	125% for 10 minutes 150% for 500ms 1000% for 1 cycle				
	Efficiency	> 95.0%				

BATTERY	Voltage (VDC)	96.0, nominal 109.2, float
	Battery	12V, 34W flame retardant High Rate, Sealed Lead-Acid
	Quantity	16
	Charge Current (ADC)	3.0
	Backup Time (min)	> 6.0
	Recharge Time	8 Hours to 90%
ENVIRONMENT	Temperature (°C)	0 to 40, operating -20 to 60, transit
	Altitude (m)	2,000, operating 12,000, transit
	Humidity	5.0% to 90.0%, non condensing
	Audible (dBA)	50-55 @ 1m from front of unit
	Heat Dissipation (BTU/hr)	2819.56
AGENCIES	EMC	FCC Part 15J Class A EN 55022 Class A/ CISPR 22 EN 50091-2 IEC 61000-3-2
	Safety Agencies	UL1778 4 th Ed. cUL to CSA22.2 No.107.1 CE: IEC62040, w/CB report and certificate IEC61000-4-2, Electrostatic Discharge IEC61000-4-3, Radiated Electromagnetic Field Immunity IEC61000-4-4, Electrical Fast Transient/ Burst Immunity IEC61000-4-5, Surge Immunity IEC61000-4-6, Immunity to Conducted Radio Frequency Disturbances IEC61000-4-8, Power Frequency Magnetic Field Immunity IEC61000-4-11, Voltage Dips, Short Interruptions, and Voltage Variations
	RoHS	All units are RoHS compliant
OTHER	Communication	RS-232 USB DB-9 Dry Contacts Internal SNMP Adapter (option)
	Unit Weight	348 lbs. / 157 kg.
	Shipping Weight	443 lbs. / 200 kg.
	Plug & Receptacle*	L6-30P (2)5-20R (1)L6-30R (Standard)

* Hardwire unit is optional. Alternative Plug & Receptacle available - Contact factory for part numbers.

NOISE REJECTION-ISOLATION: With unit under power and an ANSI/IEEE C62.41 Cat. A pulse applied either normal or common mode at the input, the noise output voltage will be less than 10V normal mode and less than 0.5V common mode in all four quadrants (CM-NM, NM-NM, CM-CM, NM-CM).

SURGE VOLTAGE WITHSTAND CAPABILITY: Tested under power to ANSI/IEEE C62.41 Cat. A & B (formerly IEEE587-1980). Cat. A - 6000V @ 200 amps, 0.5 usec risetime, 100 kHz decay, Cat. B - 6000V @ 500 amps, 0.5 usec risetime, 100 kHz decay.

Compatible External (Extended Run) Battery Cabinets:

Model: D9632-22 Description: 4 Pack (32 Batt) Extended Run Battery Cabinet

Model: D9648-22 Description: 6 Pack (48 Batt) Extended Run Battery Cabinet

ABCDEF5200-22 TYPICAL RUN-TIMES (MINs)				
	25% (1170 W)	50% (2340 W)	75% (3510 W)	100% (4680 W)
Internal Batteries Only	20	11	8	6
Internal + 1) D9632-22	90	50	35	25
Internal + 2) D9632-22	170	100	70	50
Internal + 3) D9632-22	275	160	110	80
Internal + 4) D9632-22	375	220	150	110
Internal + 5) D9632-22	500	300	200	150
Internal + 1) D9648-22	130	75	50	35
Internal + 2) D9648-22	275	160	110	80
Internal + 3) D9648-22	425	250	170	130
Internal + 4) D9648-22	625	350	240	180
Internal + 5) D9648-22	>12 Hrs	475	325	240

Notes: Run-Times are based on new fully charged batteries at 25 deg C ambient.

Battery Life Disclaimer: Powervar's standard battery warranty applies only to UPS and UPM products which are continuously connected to AC mains power, except during utility power outages. Products which are regularly and intentionally disconnected from AC mains power will experience battery discharge/charge cycles potentially far more numerous than those for which the battery was designed. As a result, products used in such applications will experience substantially reduced battery life. For that reason, Powervar's standard battery warranty does not apply for applications in which the UPS or UPM product is regularly and intentionally disconnected from AC mains power. Powervar UPS and UPM products used in such applications shall receive a 90 day warranty on batteries.

Warranty/Support: Powervar warrants the electronics and transformers used in its uninterruptible power supplies to be free from defects in materials and workmanship for a period of three years from the date of shipment. Batteries are warranted for a period of two years from the date of shipment for standby use; 90 days for cyclic use. For North American service or support on any Powervar product, please contact Powervar Technical Support at (800) 369-7179 (in Illinois call (847-596-7000). For service and support in EMEA, contact Powervar, Ltd. in the United Kingdom at +44 (0) 1793 553980. Or visit the Powervar website at www.Powervar.com.

Powervar, Inc. - 1450 Lakeside Drive, Waukegan, IL 60085

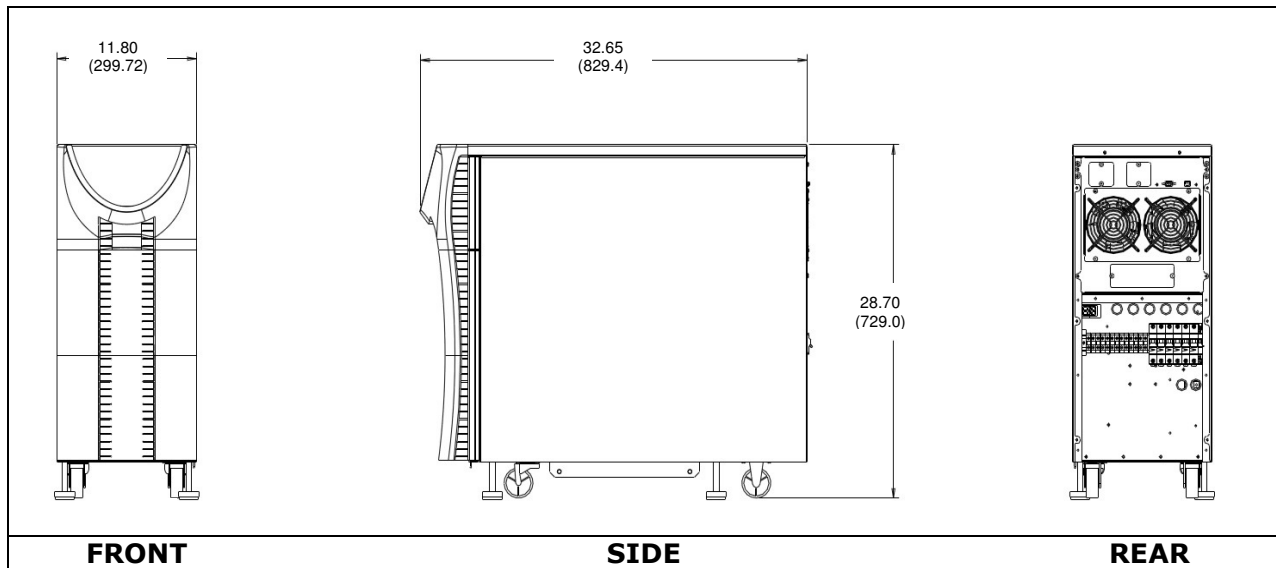

	Model	ABCDEF6000-22				
	Topology	True On-Line, Double-Conversion, IGBT Design, Internal Isolation Transformer				
INPUT	Voltage (VAC)	200	208	220	230	240
	Voltage Range (VAC)	140-230	146-239	154-253	161-264	168-276
	Voltage Tolerance	+ 15% ~ -30% before switching to batteries				
	Frequency (Hz)	50/60				
	Frequency Tolerance	42 Hz to 69 Hz before switching to batteries				
	Input PF	> 0.95				
	Input Current THD	< 5.0%				
	Input Connection	Hardwired Standard; Line Cord Optional (Consult factory)				
Input Capacity	6480 VA					
OUTPUT	Capacity	6000VA/ 5400W				
	Voltage (VAC)	200	120/208/240	220	230	120/208/240
	Voltage Regulation	± 3.0% Max, ± 1.0% Normal				
	Output Voltage THD	< 3.0%				
	Power Factor	0.9				
	Step Load Response	± 4.0% for 50% step load change ± 6.0% for 100% step load change Return to ±3.0% of nominal within 3 cycles				
	Crest Factor	3:1				
	Frequency (Hz)	50/60				
	Frequency Regulation	± 0.1Hz				
	Overload	125% for 2 minutes 150% for 30 seconds 300% for 500ms				
	Efficiency	AC-AC >85.0% DC-AC >78.0%				
	Common Mode Noise	< 0.5 VRMS				
Output Connection	Hardwired Standard; Output Receptacles Optional (Consult factory)					
BYPASS	Input Voltage (VAC)	200	208	220	230	240
	Output Voltage (VAC)	200	120/208/240	220	230	120/208/240
	Transformer Voltage Regulation	± 3.0%				
	Overload	125% for 10 minutes 150% for 500ms 1000% for 1 cycle				
	Efficiency	> 95.0%				

BATTERY	Voltage (VDC)	96.0, nominal 109.2, float
	Battery	12V, 34W flame retardant High Rate, Sealed Lead-Acid
	Quantity	16
	Charge Current (ADC)	3.0
	Backup Time (min)	> 5.0
	Recharge Time	8 Hours to 90%
ENVIRONMENT	Temperature (°C)	0 to 40, operating -20 to 60, transit
	Altitude (m)	2,000, operating 12,000, transit
	Humidity	5.0% to 90.0%, non condensing
	Audible (dBA)	50-55 @ 1m from front of unit
	Heat Dissipation (BTU/hr)	3252
AGENCIES	EMC	FCC Part 15J Class A EN 55022 Class A/ CISPR 22 EN 50091-2 IEC 61000-3-2
	Safety Agencies	UL1778 4 th Ed. cUL to CSA22.2 No.107.1 CE: IEC62040, w/CB report and certificate IEC61000-4-2, Electrostatic Discharge IEC61000-4-3, Radiated Electromagnetic Field Immunity IEC61000-4-4, Electrical Fast Transient/ Burst Immunity IEC61000-4-5, Surge Immunity IEC61000-4-6, Immunity to Conducted Radio Frequency Disturbances IEC61000-4-8, Power Frequency Magnetic Field Immunity IEC61000-4-11, Voltage Dips, Short Interruptions, and Voltage Variations
	RoHS	All units are RoHS compliant
OTHER	Communication	RS-232 USB DB-9 Dry Contacts Internal SNMP Adapter (option)
	Unit Weight	348 lbs. / 157 kg.
	Shipping Weight	443 lbs. / 200 kg.
	Plug & Receptacle*	*Hardwired unit is standard. Plug & Receptacle is optional. Contact factory for part numbers.

NOISE REJECTION-ISOLATION: With unit under power and an ANSI/IEEE C62.41 Cat. A pulse applied either normal or common mode at the input, the noise output voltage will be less than 10V normal mode and less than 0.5V common mode in all four quadrants (CM-NM, NM-NM, CM-CM, NM-CM).

SURGE VOLTAGE WITHSTAND CAPABILITY: Tested under power to ANSI/IEEE C62.41 Cat. A & B (formerly IEEE587-1980). Cat. A - 6000V @ 200 amps, 0.5 usec risetime, 100 kHz decay, Cat. B - 6000V @ 500 amps, 0.5 usec risetime, 100 kHz decay.

Compatible External (Extended Run) Battery Cabinets:

Model: D9632-22 Description: 4 Pack (32 Batt) Extended Run Battery Cabinet

Model: D9648-22 Description: 6 Pack (48 Batt) Extended Run Battery Cabinet

ABCDEF6000-22 TYPICAL RUN-TIMES (MIN)				
	25% (1350 W)	50% (2700 W)	75% (4050 W)	100% (5400 W)
Internal Batteries Only	18	10	7	5
Internal + 1) D9632-22	80	45	30	22
Internal + 2) D9632-22	160	90	60	45
Internal + 3) D9632-22	240	140	95	70
Internal + 4) D9632-22	325	190	120	90
Internal + 5) D9632-22	450	250	160	130
Internal + 1) D9648-22	120	65	45	30
Internal + 2) D9648-22	225	140	95	70
Internal + 3) D9648-22	400	220	150	110
Internal + 4) D9648-22	550	325	210	150
Internal + 5) D9648-22	> 12 Hrs	425	275	200

Notes: Run-Times are based on new fully charged batteries at 25 deg C ambient.

Battery Life Disclaimer: Powervar's standard battery warranty applies only to UPS and UPM products which are continuously connected to AC mains power, except during utility power outages. Products which are regularly and intentionally disconnected from AC mains power will experience battery discharge/charge cycles potentially far more numerous than those for which the battery was designed. As a result, products used in such applications will experience substantially reduced battery life. For that reason, Powervar's standard battery warranty does not apply for applications in which the UPS or UPM product is regularly and intentionally disconnected from AC mains power. Powervar UPS and UPM products used in such applications shall receive a 90 day warranty on batteries.

Warranty/Support: Powervar warrants the electronics and transformers used in its uninterruptible power supplies to be free from defects in materials and workmanship for a period of three years from the date of shipment. Batteries are warranted for a period of two years from the date of shipment for standby use; 90 days for cyclic use. For North American service or support on any Powervar product, please contact Powervar Technical Support at (800) 369-7179 (in Illinois call (847-596-7000). For service and support in EMEA, contact Powervar, Ltd. in the United Kingdom at +44 (0) 1793 553980. Or visit the Powervar website at www.Powervar.com.

Powervar, Inc. - 1450 Lakeside Drive, Waukegan, IL 60085

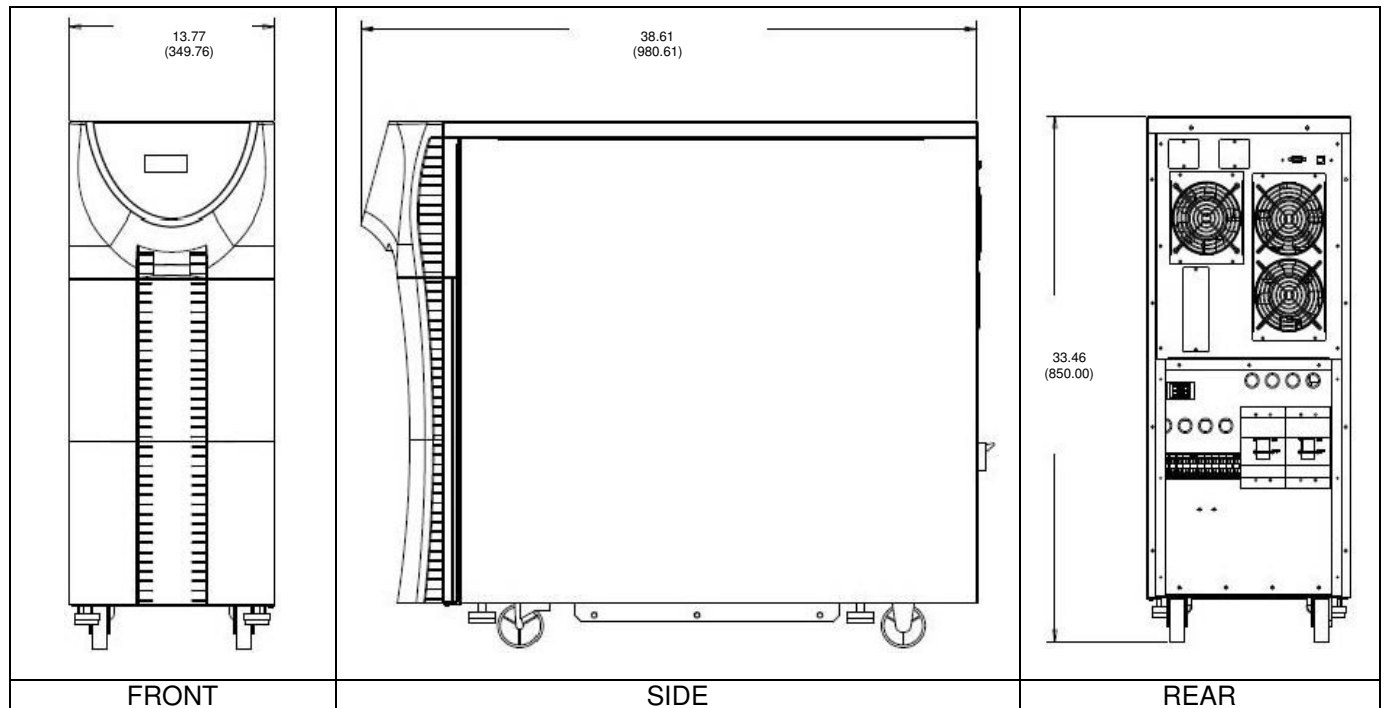

	Model	ABCDEF8000-22			ABCDEF10.0-22	
	Topology	True On line, Double-Conversion, IGBT Design, Internal Isolation Transformer				
INPUT	Voltage (VAC)	200	208	220	230	240
	Voltage Range (VAC)	140-230	146-239	154-253	161-264	168-276
	Voltage Tolerance	+ 15% ~ -30% before switching to batteries				
	Frequency (Hz)	50/60				
	Frequency Tolerance	42 Hz to 69 Hz before switching to batteries				
	Input PF	> 0.95				
	Input Current THD	< 5.0%				
	Input Connection	Hardwired Standard; Line Cord Optional (Consult factory)				
Input Capacity	9195W			11494W		
OUTPUT	Capacity	8000 VA / 7200W			10000 VA / 9000W	
	Voltage (VAC)	200	120 208 240	220	230	120 208 240
	Voltage Regulation	± 3.0% Max, ± 1.0% Normal				
	Output Voltage THD	< 3.0%				
	Power Factor	0.9				
	Step Load Response	± 4.0% for 50% step load change ± 6.0% for 100% step load change Return to ± 3.0% of nominal within 3 cycles				
	Crest Factor	3:1				
	Frequency (Hz)	50 or 60				
	Frequency Regulation	± 0.1Hz				
	Overload	125% for 2 minutes 150% for 30 seconds 300% for 500ms				
	Efficiency	AC-AC >87.0% DC-AC >85.0%				
	Common Mode Noise	< 0.5 VRMS				
	Output Connection	Hardwired Standard; Output Receptacles Optional (Consult factory)				

BYPASS	Input Voltage (VAC)	200	208	220	230	240
	Output Voltage (VAC)	200	120 208 240	220	230	120 208 240
	Transformer Voltage Regulation	± 3.0%				
	Overload	125% for 10 minutes 150% for 500ms 1000% for 1 cycle				
	Efficiency	> 95.0%				
BATTERY	Voltage (VDC)	288.0, nominal 327.6, float				
	Battery	12V, 34W flame retardant High Rate, Sealed Lead-Acid				
	Quantity	24				
	Charge Current (ADC)	2.5				
	Backup Time (min)	> 5.0				
	Recharge Time	8 hours to 90%				
ENVIRONMENT	Temperature (°C)	0 to 40, operating -20 to 60, transit				
	Altitude (m)	2,000, operating 12,000, transit				
	Humidity	5.0% to 90.0%, non condensing				
	Audible (dBA)	55-60 @ 1m from front of unit				
	Heat Dissipation (BTU/hr)	4239				
AGENCIES	EMC	FCC Part 15J Class A EN 55022 Class A/ CISPR 22 EN 50091-2 IEC 61000-3-2				
	Safety Agencies	UL1778 4 th Ed. cUL to CSA22.2 No.107.1 IEC62040, w/CB report and certificate IEC61000-4-2, Electrostatic Discharge IEC61000-4-3, Radiated Electromagnetic Field Immunity IEC61000-4-4, Electrical Fast Transient/ Burst Immunity IEC61000-4-5, Surge Immunity IEC61000-4-6, Immunity to Conducted Radio Frequency Disturbances IEC61000-4-8, Power Frequency Magnetic Field Immunity IEC61000-4-11, Voltage Dips, Short Interruptions, and Voltage Variations				
	RoHS	All units are RoHS compliant				
OTHER	Communication	RS-232 USB DB-9 Dry Contacts Internal SNMP Adapter (optional)				
	Unit Weight	449.0 lbs. / 203.7 kg				
	Shipping Weight	641.5 lbs. / 291.0 kg				
	Plug & Receptacle*	*Hardwire unit is standard. Plug & receptacle is optional. Contact factory for part numbers.				

NOISE REJECTION-ISOLATION: With unit under power and an ANSI/IEEE C62.41 Cat. A pulse applied either normal or common mode at the input, the noise output voltage will be less than 10V normal mode and less than 0.5V common mode in all four quadrants (CM-NM, NM-NM, CM-CM, NM-CM).

SURGE VOLTAGE WITHSTAND CAPABILITY: Tested under power to ANSI/IEEE C62.41 Cat. A & B (formerly IEEE587-1980). Cat. A - 6000V @ 200 amps, 0.5 usec risetime, 100 kHz decay, Cat. B - 6000V @ 500 amps, 0.5 usec risetime, 100 kHz decay.

Compatible External (Extended Run) Battery Cabinets:
 Model: D28848-22 Description: 2 String x 24 (48 Batt) Extended Run Battery Cabinet

ABCDEF8000-22 TYPICAL RUN-TIMES (MINs)				
	25% (1800 W)	50% (3600 W)	75% (5400 W)	100% (7200 W)
Internal Batteries Only	65	25	15	10
Internal + 1) D28848-22	275	120	70	50
Internal + 2) D28848-22	525	220	140	95
Internal + 3) D28848-22	>12 Hrs	350	210	140
Internal + 4) D28848-22	>12 Hrs	500	275	200
Internal + 5) D28848-22	>12 Hrs	650	375	250

Notes: Run-Times are based on new fully charged batteries at 25 deg C ambient.

Compatible External (Extended Run) Battery Cabinets:
 Model: D28848-22 Description: 2 String x 24 (48 Batt) Extended Run Battery Cabinet

ABCDEF10.0-22 TYPICAL RUN-TIMES (MINs)				
	25% (2250 W)	50% (4500 W)	75% (6750 W)	100% (9000 W)
Internal Batteries Only	50	21	13	9
Internal + 1) D28848-22	200	90	55	35
Internal + 2) D28848-22	400	170	95	70
Internal + 3) D28848-22	650	275	150	100
Internal + 4) D28848-22	>12 Hrs	375	220	150
Internal + 5) D28848-22	>12 Hrs	500	275	200

Notes: Run-Times are based on new fully charged batteries at 25 deg C ambient.

Battery Life Disclaimer: Powervar's standard battery warranty applies only to UPS and UPM products which are continuously connected to AC mains power, except during utility power outages. Products which are regularly and intentionally disconnected from AC mains power will experience battery discharge/charge cycles potentially far more numerous than those for which the battery was designed. As a result, products used in such applications will experience substantially reduced battery life. For that reason, Powervar's standard battery warranty does not apply for applications in which the UPS or UPM product is regularly and intentionally disconnected from AC mains power. Powervar UPS and UPM products used in such applications shall receive a 90 day warranty on batteries.

Warranty/Support: Powervar warrants the electronics and transformers used in its uninterruptible power supplies to be free from defects in materials and workmanship for a period of three years from the date of shipment. Batteries are warranted for a period of two years from the date of shipment for standby use; 90 days for cyclic use. For North American service or support on any Powervar product, please contact Powervar Technical Support at (800) 369-7179 (in Illinois call (847-596-7000)). For service and support in EMEA, contact Powervar, Ltd. in the United Kingdom at +44 (0) 1793 553980. Or visit the Powervar website at www.Powervar.com.

Powervar, Inc. - 1450 Lakeside Drive, Waukegan, IL 60085

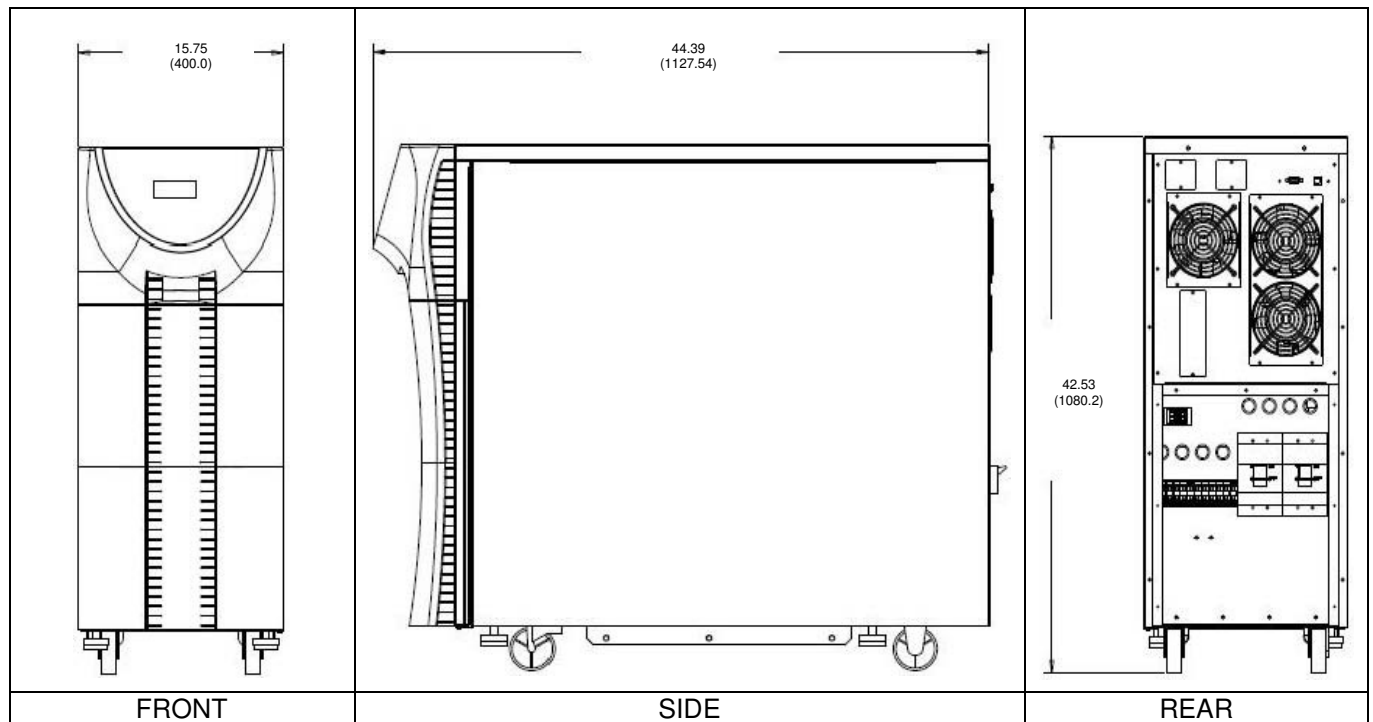

Model		ABCDEF12.0-22			ABCDEF15.0-22	
Topology		True On line, Double-Conversion, IGBT Design, Internal Isolation Transformer				
INPUT	Voltage (VAC)	200	208	220	230	240
	Voltage Range (VAC)	140-230	146-239	154-253	161-264	168-276
	Voltage Tolerance	+ 15% ~ -30% before switching to batteries				
	Frequency (Hz)	50/60				
	Frequency Tolerance	42 Hz to 69 Hz before switching to batteries				
	Input PF	> 0.95				
	Input Current THD	< 5.0%				
	Input Connection	Hardwired Standard; Line Cord Optional (Consult factory)				
	Input Capacity	13793W			17241W	
OUTPUT	Capacity	12000 VA / 10800W			15000 VA / 13500W	
	Voltage (VAC)	200	120 208 240	220	230	120 208 240
	Voltage Regulation	± 3.0% Max, ± 1.0% Normal				
	Output Voltage THD	< 3.0%				
	Power Factor	0.9				
	Step Load Response	± 4.0% for 50% step load change ± 6.0% for 100% step load change Return to ± 3.0% of nominal within 3 cycles				
	Crest Factor	3:1				
	Frequency (Hz)	50 or 60				
	Frequency Regulation	± 0.1Hz				
	Overload	125% for 2 minutes 150% for 30 seconds 300% for 500ms				
	Efficiency	AC-AC >87.0% DC-AC >85.0%				
	Common Mode Noise	< 0.5 VRMS				
	Output Connection	Hardwired Standard; Output Receptacles Optional (Consult factory)				

BYPASS	Input Voltage (VAC)	200	208	220	230	240
	Output Voltage (VAC)	200	120 208 240	220	230	120 208 240
	Transformer Voltage Regulation	± 3.0%				
	Overload	125% for 10 minutes 150% for 500ms 1000% for 1 cycle				
	Efficiency	> 95.0%				
BATTERY	Voltage (VDC)	288.0, nominal 327.6, float				
	Battery	12V, 34W flame retardant High Rate, Sealed Lead-Acid				
	Quantity	24				
	Charge Current (ADC)	2.5				
	Backup Time (min)	> 5.0				
	Recharge Time	8 hours to 90%				
ENVIRONMENT	Temperature (°C)	0 to 40, operating -20 to 60, transit				
	Altitude (m)	2,000, operating 12,000, transit				
	Humidity	5.0% to 90.0%, non condensing				
	Audible (dBA)	55-60 @ 1m from front of unit				
	Heat Dissipation (BTU/hr)	4239				
AGENCIES	EMC	FCC Part 15J Class A EN 55022 Class A/ CISPR 22 EN 50091-2 IEC 61000-3-2				
	Safety Agencies	UL1778 4 th Ed. cUL to CSA22.2 No.107.1 IEC62040, w/CB report and certificate IEC61000-4-2, Electrostatic Discharge IEC61000-4-3, Radiated Electromagnetic Field Immunity IEC61000-4-4, Electrical Fast Transient/ Burst Immunity IEC61000-4-5, Surge Immunity IEC61000-4-6, Immunity to Conducted Radio Frequency Disturbances IEC61000-4-8, Power Frequency Magnetic Field Immunity IEC61000-4-11, Voltage Dips, Short Interruptions, and Voltage Variations				
	RoHS	All units are RoHS compliant				
OTHER	Communication	RS-232 USB DB-9 Dry Contacts Internal SNMP Adapter (optional)				
	Unit Weight	719.0lbs/ 326.1kg (12kVA) 739.0lbs/335.2kg (15kVA)				
	Shipping Weight	807.0lbs. / 366.0 kg (12kVA) 827.0lbs/ 375.1kg (15kVA)				
	Plug & Receptacle*	*Hardwire unit is standard. Plug & receptacle is optional. Contact factory for part numbers.				

NOISE REJECTION-ISOLATION: With unit under power and an ANSI/IEEE C62.41Cat. A pulse applied either normal or common mode at the input, the noise output voltage will be less than 10V normal mode and less than 0.5V common mode in all four quadrants (CM-NM, NM-NM, CM-CM, NM-CM).

SURGE VOLTAGE WITHSTAND CAPABILITY: Tested under power to ANSI/IEEE C62.41 Cat. A & B (formerly IEEE587-1980). Cat. A - 6000V @ 200 amps, 0.5 usec risetime, 100 kHz decay, Cat. B - 6000V @ 500 amps, 0.5 usec risetime, 100 kHz decay.

Compatible External (Extended Run) Battery Cabinets:
 Model: D28848-22 Description: 2 String x 24 (48 Batt) Extended Run Battery Cabinet

ABCDEF12.0-22 TYPICAL RUN-TIMES (MINs)				
	25% (2700 W)	50% (5400 W)	75% (8100 W)	100% (10800 W)
Internal Batteries Only	35	17	10	7
Internal + 1) D28848-22	160	70	40	25
Internal + 2) D28848-22	300	130	80	55
Internal + 3) D28848-22	475	210	120	85
Internal + 4) D28848-22	675	275	170	110
Internal + 5) D28848-22	>12 Hrs	375	230	150

Notes: Run-Times are based on new fully charged batteries at 25 deg C ambient.

Compatible External (Extended Run) Battery Cabinets:
 Model: D28848-22 Description: 2 String x 24 (48 Batt) Extended Run Battery Cabinet

ABCDEF15.0-22 TYPICAL RUN-TIMES (MINs)				
	25% (3375 W)	50% (6750 W)	75% (10125 W)	100% (13500 W)
Internal Batteries Only	25	13	7	5
Internal + 1) D28848-22	120	50	30	22
Internal + 2) D28848-22	230	100	60	45
Internal + 3) D28848-22	350	150	100	70
Internal + 4) D28848-22	500	220	130	90
Internal + 5) D28848-22	650	275	170	110

Notes: Run-Times are based on new fully charged batteries at 25 deg C ambient.

Battery Life Disclaimer: Powervar's standard battery warranty applies only to UPS and UPM products which are continuously connected to AC mains power, except during utility power outages. Products which are regularly and intentionally disconnected from AC mains power will experience battery discharge/charge cycles potentially far more numerous than those for which the battery was designed. As a result, products used in such applications will experience substantially reduced battery life. For that reason, Powervar's standard battery warranty does not apply for applications in which the UPS or UPM product is regularly and intentionally disconnected from AC mains power. Powervar UPS and UPM products used in such applications shall receive a 90 day warranty on batteries.

Warranty/Support: Powervar warrants the electronics and transformers used in its uninterruptible power supplies to be free from defects in materials and workmanship for a period of three years from the date of shipment. Batteries are warranted for a period of two years from the date of shipment for standby use; 90 days for cyclic use. For North American service or support on any Powervar product, please contact Powervar Technical Support at (800) 369-7179 (in Illinois call (847-596-7000). For service and support in EMEA, contact Powervar, Ltd. in the United Kingdom at +44 (0) 1793 553980. Or visit the Powervar website at www.Powervar.com.

Powervar, Inc. - 1450 Lakeside Drive, Waukegan, IL 60085



Both the input and output connections of this UPS exhibit dangerous high voltage, which represents a hazard to personal life or safety. Please read this manual carefully prior to installation, operation, and use. Please pay close attention to any caution labels and statements. Only trained, authorized service personnel should be allowed to remove UPS covers or perform maintenance tasks.

2.0 Structure and Basic Principles

2.1 General Structure

2.1.1 Security Plus Front Panel and Rear Panel Structure

The operator panel layout of the Security Plus UPS is illustrated in Fig. 2-1 and Table 2-1.

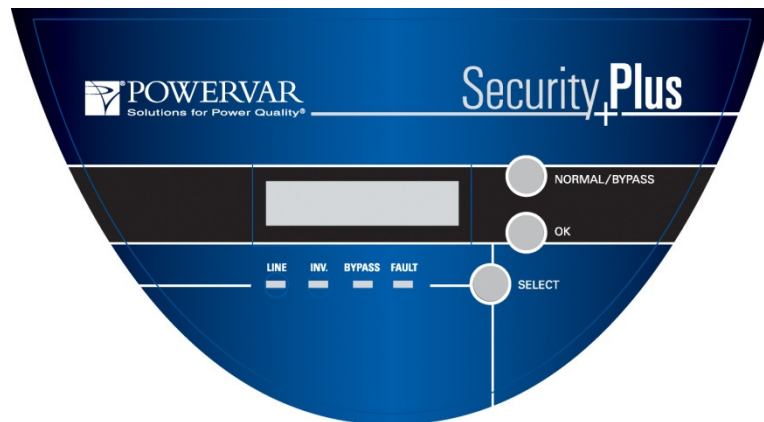

Figure 2-1

Item	Function
LCD Display Window	Displays status/programming information about UPS
Normal/Bypass Button	Turns UPS inverter on and off (when off UPS is in bypass)
OK Button	Press to confirm selection of a function
Select Button	Used to select or navigate through the UPS menu
Line LED Indicator	ON - main supply normal; OFF —no main supply;
Inverter LED Indicator	ON - Inverter On; OFF —Inverter Off
Bypass LED Indicator	ON - Indicates UPS is in bypass mode BLINKING - Bypass voltage is out of range. Bypass transfer is prohibited.
Fault LED Indicator	ON - UPS is in fault mode; OFF - UPS normal or turned off

Table 2-1

2.1.2 Security Plus Display/Controls Operation

The menu visible in the LCD display of the Security Plus UPS is illustrated in Fig. 2-2 and 2-3. The various LCD displays are accessed using the front panel controls of the UPS as follows:

Function Button Explanation

The **NORMAL/BYPASS** button is used to start and stop the inverter. When the inverter is stopped, the UPS will be in bypass.

The **SELECT** button is used to scroll through various display screens and must be pressed for 3 seconds to change UPS programming modes.

The **OK** button is only functional when in the programming mode (Settings Menu)

Display Content and Corresponding Operation

Default Mode

After startup, the LCD displays a message showing the UPS name and model number.

This message will display for 8 seconds unless the **SELECT** button is pushed. After either 8 seconds or if the **SELECT** button is pushed, the UPS display changes to either the "OPERATION MODE" display (i.e. NORM, BYP, BATT) or the "FAULT" display (if the UPS has detected a fault condition). In the absence of a UPS fault condition, the "OPERATION MODE" display is the default display.

UPS Parameters Mode

When the UPS is operating normally, pressing the "SELECT" button will allow switching to the UPS parameter displays.

	When in the UPS Parameters mode, if no operation is performed for 30 seconds, the Parameters mode will be cancelled and the UPS display will return to the default "OPERATION MODE" display.
---	---

The parameter displays are as follows:

1. Operation Mode
2. Output voltage display
3. Input voltage display
4. Input frequency display
5. Output frequency display
6. Output load percentage display
7. Battery voltage display
8. Battery percentage charge display
9. UPS state one display
10. UPS state two display

While in the Parameters mode, pressing the "SELECT" button for 3 seconds will cause the UPS to enter the UPS Settings Mode. Refer to Figure 2.3 for the Parameter Setting Menu in the UPS Settings Mode.

POWERTVAR Security Plus UPS

Figure 2.2-Display Verbiage
(2-6kVA)

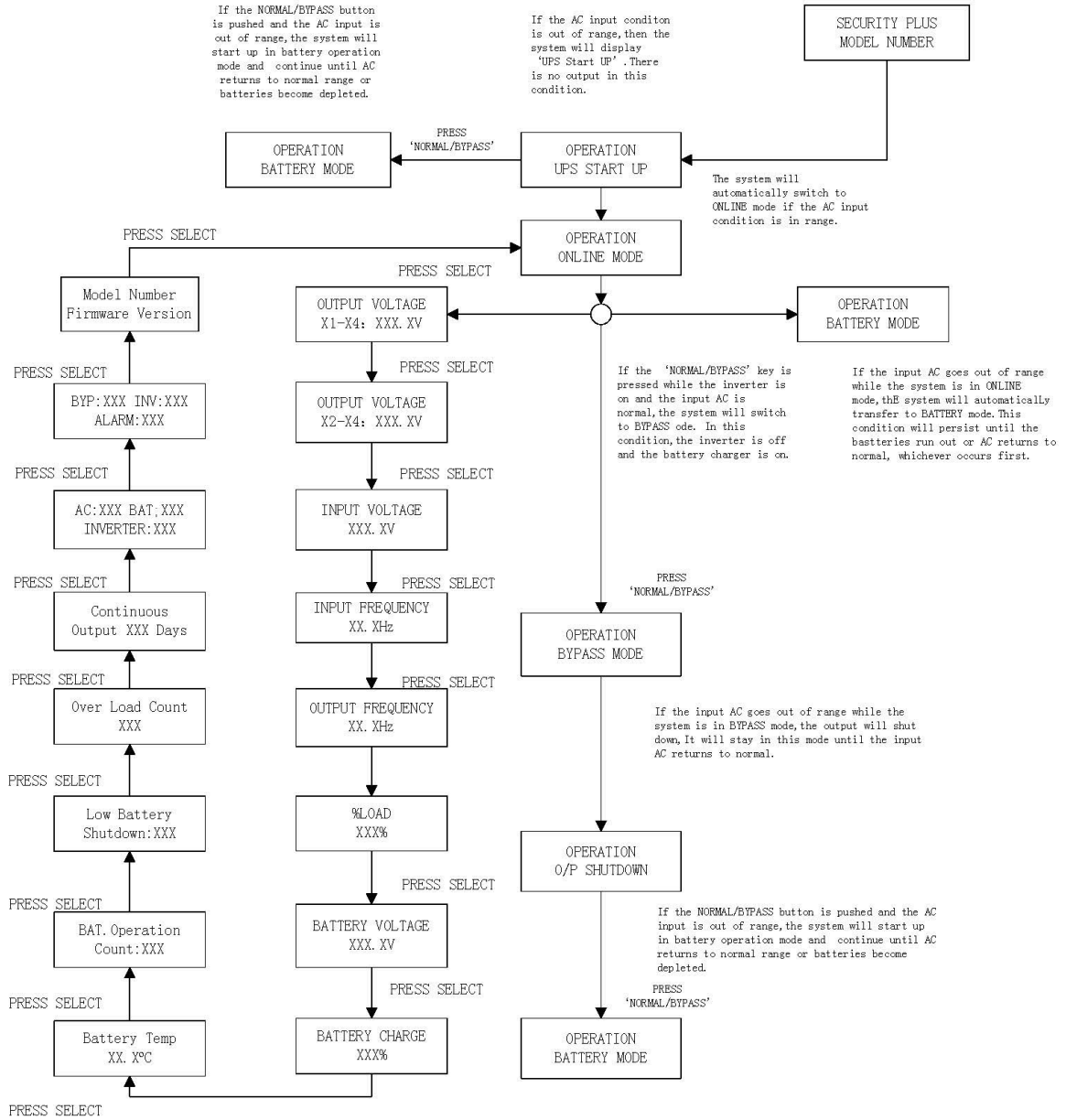

POWERRVAR Security Plus UPS

Figure 2.3-Parameters Setting Menu
(2-6 kVA)

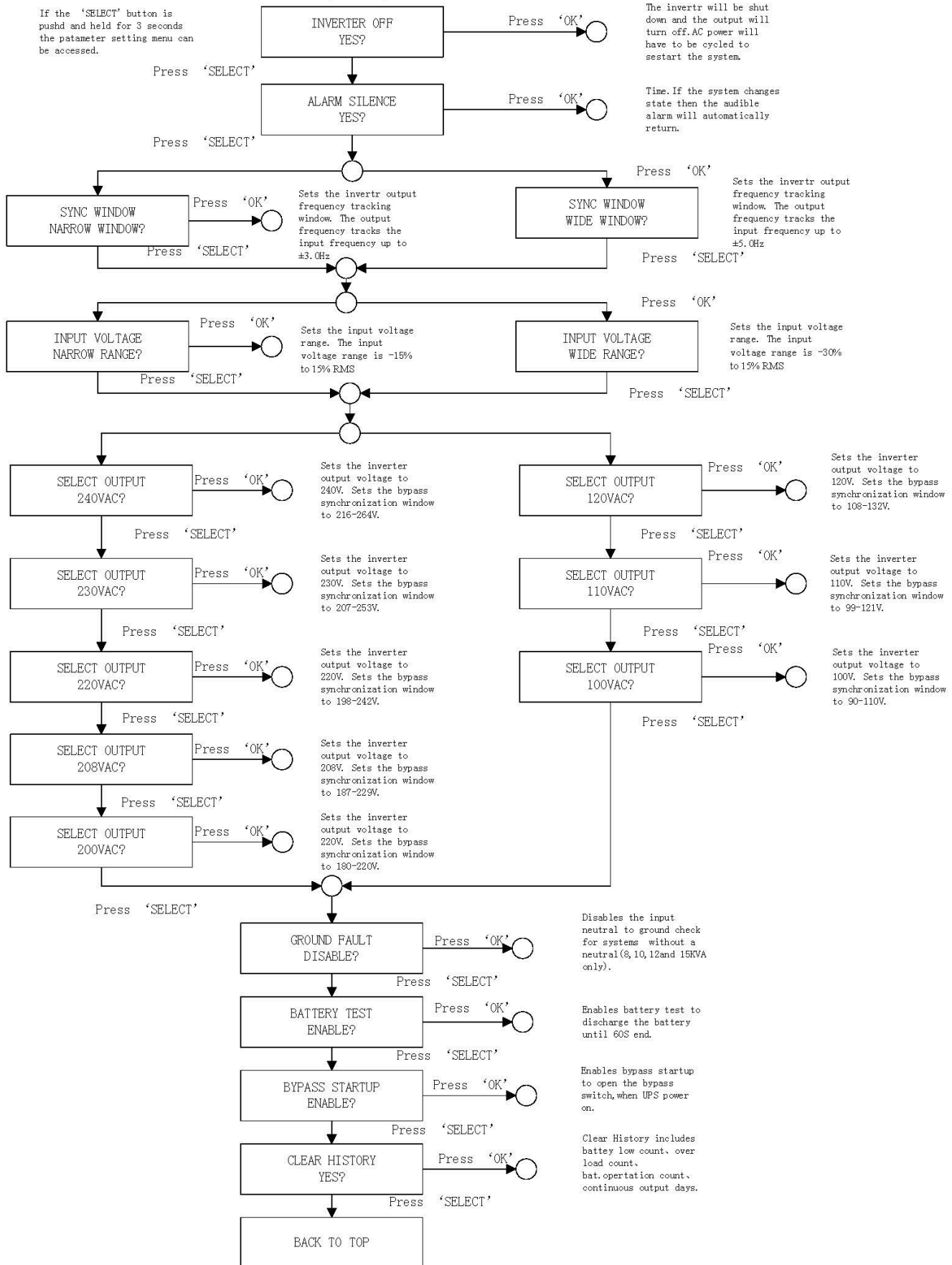

Figure 2.2 – Display Verbiage (8-15kVA)

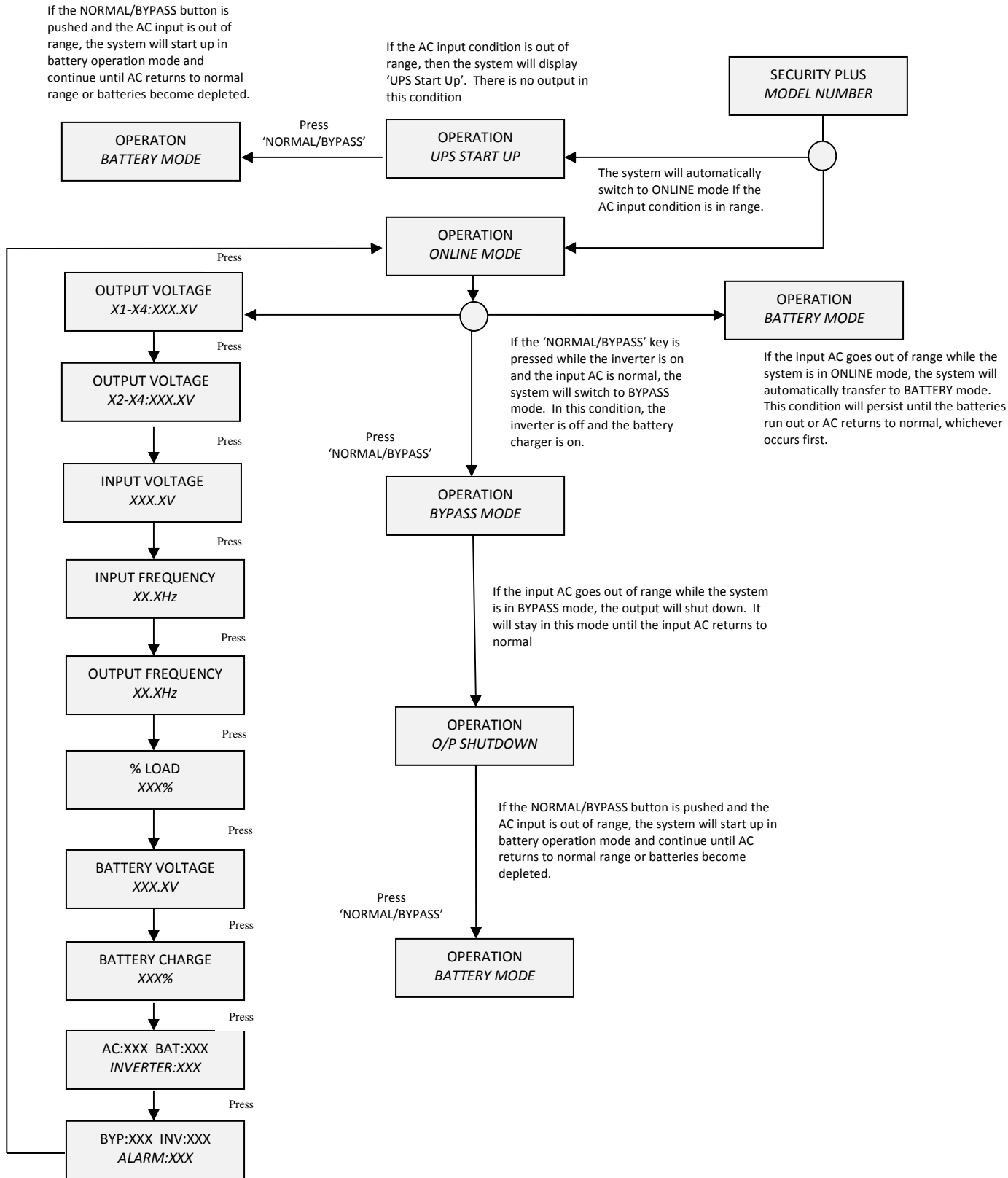
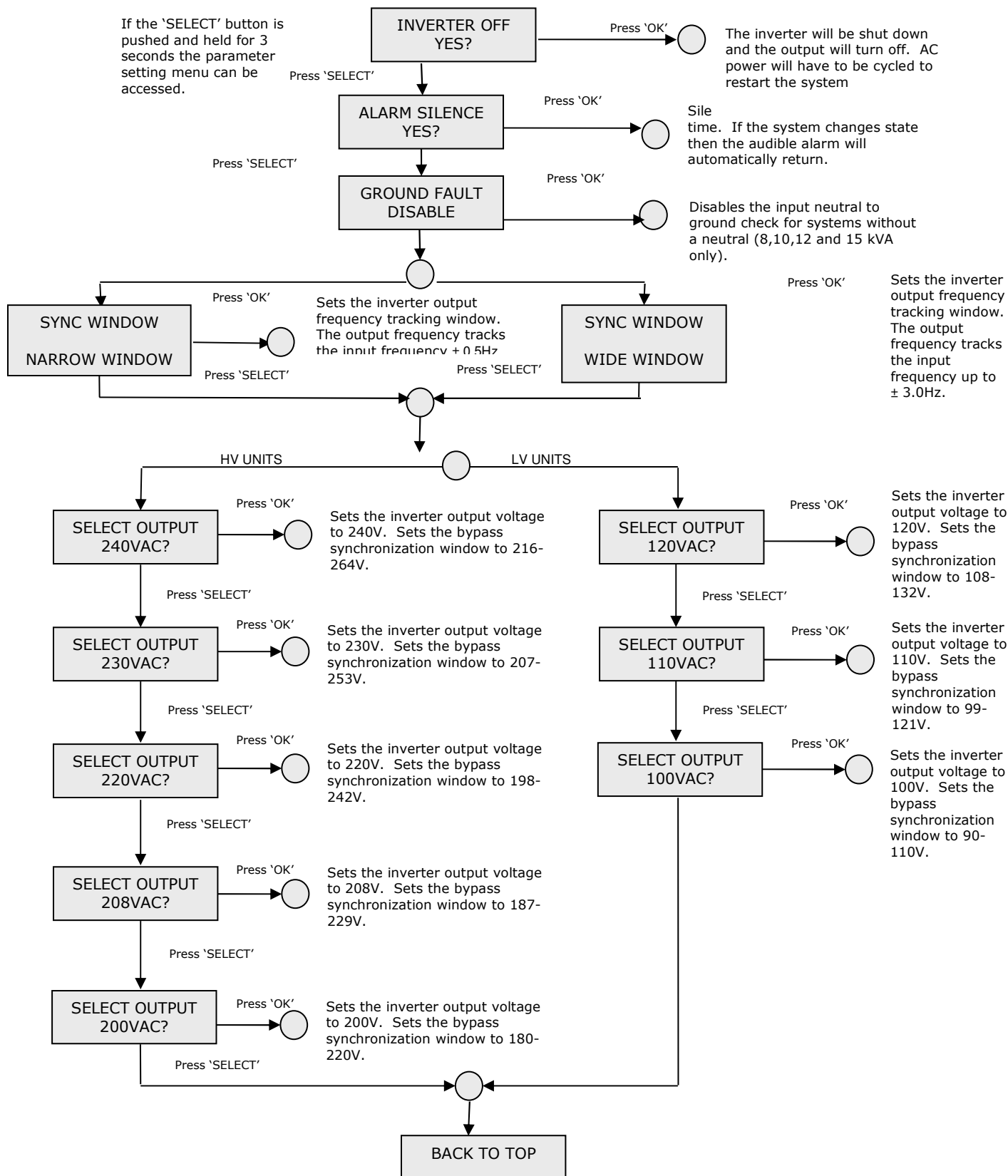

Figure 2.3 – Parameters Setting Menu (8-15kVA)



Caution: To save any changed settings the unit must be placed into Bypass operation. This is done by pressing the "NORMAL/BYPASS" button. Wait 2 minutes then press the "NORMAL/BYPASS" button again.

Settings Pages

HIGH VOLTAGE

- 1) Inverter Off Setting
- 2) Audible Alarm Enable/Disable
- 3) Frequency Window
- 4) 240V Output Setting
- 5) 230V Output Setting
- 6) 220V Output Setting
- 7) 208V Output Setting
- 8) 200V Output Setting

LOW VOLTAGE

- 1) Inverter Off Setting
- 2) Audible Alarm Enable/Disable
- 3) Frequency Window
- 4) 120V Output Setting
- 5) 110V Output Setting
- 6) 100V Output Setting

If the UPS enters a FAULT condition, it will switch to the fault display. All the fault condition displays are shown below:

- 1) Inverter fault
- 2) DC bus protection fault
- 3) Output short circuit fault
- 4) Overload protection fault (appears when UPS times out on overload and transfers to bypass)
- 5) Low battery voltage protection fault
- 6) Overload fault (appears when system is in inverter mode and detects an overload)
- 7) Over temperature protection fault
- 8) Fan fault

Item	Description	Item	Description
1	Operator Panel	6	Connection terminal block (not visible on units equipped with receptacle panel)
2	Air inlet panels	7	RS232 Interface
3	Dial panel	8	USB Interface
4	Optional SNMP Interface	9	Hot swappable cooling fans
5	Connection point for rear receptacle panel	10	Main supply and battery switches (circuit breakers)

Table 2-2

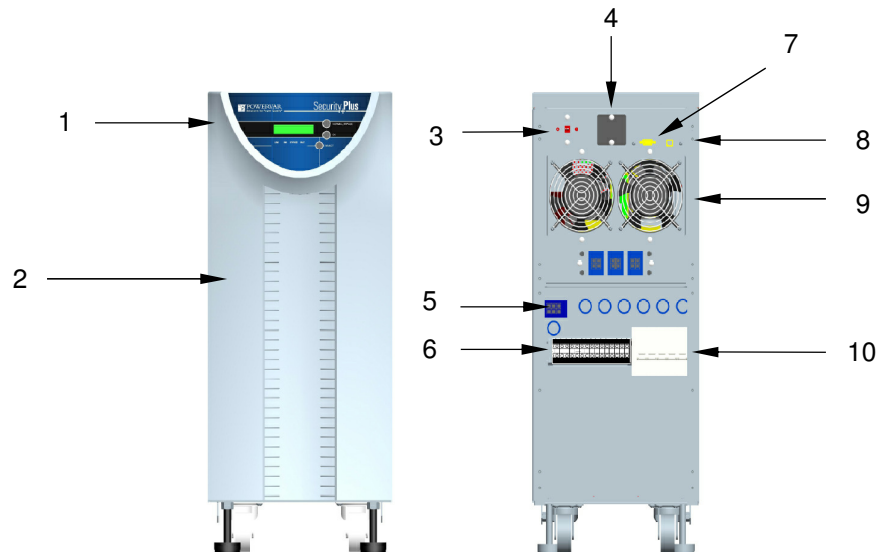

Figure 2-4

The front and rear panel layout of the Security Plus UPS is illustrated in Fig. 2-4 and Table 2-2.

2.1.3 Security Plus Terminal Connection Block Illustration (2-6kVA)

All models are factory configured for 50 or 60Hz operation. Figure 2-5 represents 2-6kVA 60Hz configuration and the 2-6kVA 50Hz configuration. Refer to Table 2-3 or Table 2-4 for the appropriate wiring configuration.

The wire connection (from left to right) of the terminal connection block on the rear is shown below:

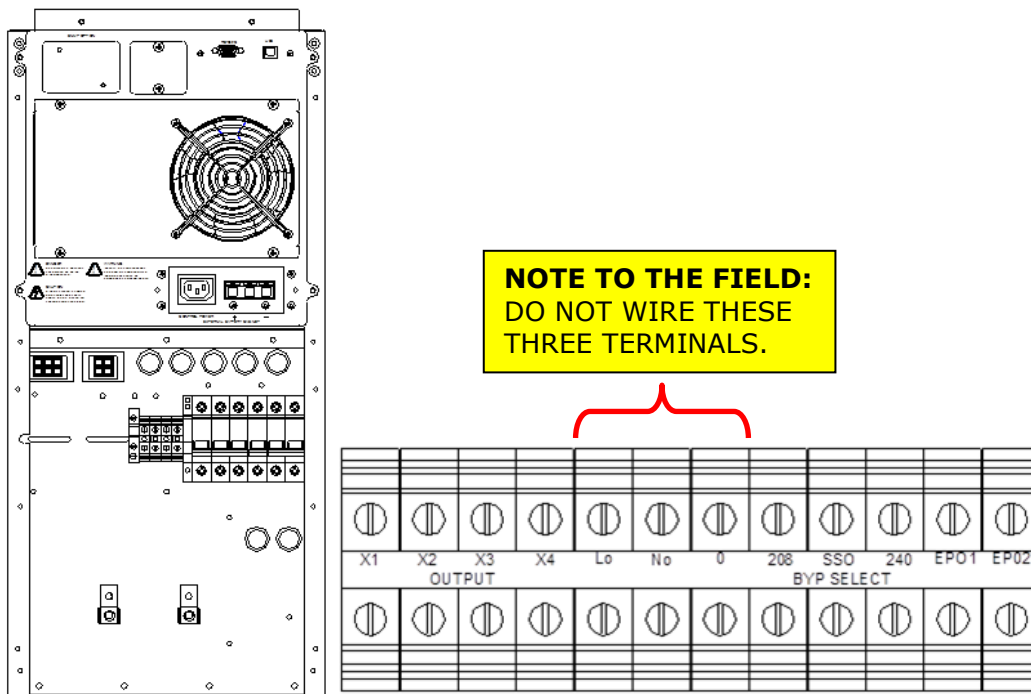

Figure 2-5A

Figure 2-5B represents the low voltage (100-120V) configuration.

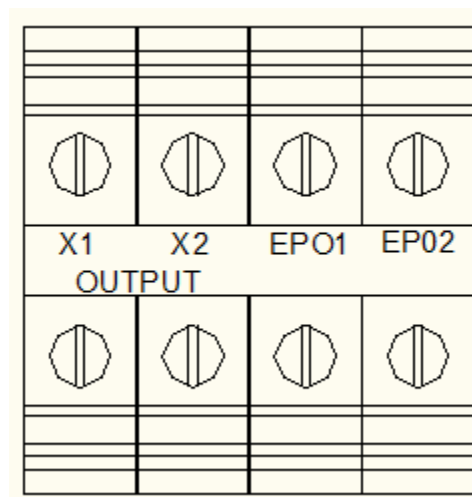

Figure 2-5B

For North American applications, high voltage models may be configured for an input voltage of either 200, 208 or 240 volts at 50 or 60 Hz. Output voltage for these models is available at 115,120, 200, 208 and 240 volts at 50 or 60 Hz. Table 2-3 illustrates how to connect to the terminal block in Figure 2-5A to achieve the desired input and output voltage configurations.

VOLTAGE RATING	INPUT		OUTPUT					BYPASS JUMPER	
	VOLTAGE	FREQ	VOLTAGE				NEUTRAL		FREQ
			X1-X4	X1-N	N-X4	X2-X4			
200	200	50/60	230	115	115	200	N	50/60	208-SSO
208	208	50/60	240	120	120	208	N	50/60	208-SSO
240	240	50/60	240	120	120	208	N	50/60	240-SSO

Table 2-3—North American Connections

NOTE: The neutral to ground connection must be properly connected for a 50 or 60 Hz configuration. Refer to Table 2-3 (for North American Connections) and table 2-4 (for International Connections) for the correct neutral to ground connection, as well as the appropriate voltage and frequency configuration.

For international applications, high voltage UPS models may be configured for an input voltage of 200, 220, 230 or 240 volts at 50 Hz. Output voltage for these models matches the input voltage at 50 Hz. Table 2-4 illustrates how to connect to the terminal block in Figure 2-5B to achieve the desired input and output voltage configurations.

VOLTAGE RATING	INPUT		OUTPUT					BYPASS JUMPER	
	VOLTAGE	FREQ	VOLTAGE				NEUTRAL		FREQ
			X1-N	X1-X3	X3-N	X2-N			
200	200	50Hz	--	--	--	200	N	50Hz	208-SSO
220	220	50Hz	220	--	--	--	N	50Hz	240-SSO
230	230	50Hz	230	--	--	--	N	50Hz	240-SSO
240	240	50Hz	240	--	--	--	N	50Hz	240-SSO

Table 2-4 – International Connections



If the EP01 and EP02 terminals are inadvertently connected together, this is effectively the same as activating the EPO switch (shown in Fig.2-5). Doing so will prevent the UPS from operating. The EPO is designed as a normally open circuit (N/O). If wiring to the EPO circuit a minimum 16 gauge wire must be used.

For field wired units, refer to the tables below for the proper conductor size and torque requirements. Only copper conductors are to be used for field wiring connections. The conductors should be rated at least 75°C or greater. The conductor recommendations listed in the chart below are intended for installations in North America. For international installations, please refer to the local and national electrical codes and standards.

RATING	INPUT CONDUCTOR (AWG)		TORQUE (in-lbs)	OUTPUT CONDUCTOR (AWG)		TORQUE (in-lbs)	GROUND (AWG)		TORQUE (in-lbs)
	MIN	MAX		MIN	MAX		MIN	MAX	
2.0kVA	12.0	6.0	20	12.0	6.0	20	12.0	6.0	20
3.0kVA	12.0	6.0	20	12.0	6.0	20	12.0	6.0	20
4.0kVA	10.0	6.0	20	10.0	6.0	20	8.0	6.0	20
5.2kVA	8.0	6.0	20	8.0	6.0	20	6.0	6.0	20
6.0Kva	8.0	6.0	20	8.0	6.0	20	6.0	6.0	20

TABLE 2-4A HIGH VOLTAGE CONDUCTOR SIZE AND TORQUE SPECIFICATIONS

RATING	INPUT CONDUCTOR (AWG)		TORQUE (in-lbs)	OUTPUT CONDUCTOR (AWG)		TORQUE (in-lbs)	GROUND (AWG)		TORQUE (in-lbs)
	MIN	MAX		MIN	MAX		MIN	MAX	
2.0kVA	10.0	6.0	20	10.0	6.0	20	8.0	6.0	20
3.0kVA	8.0	6.0	20	8.0	6.0	20	6.0	6.0	20

TABLE 2-4B LOW VOLTAGE CONDUCTOR SIZE AND TORQUE SPECIFICATIONS

Figure 2-6 represents the circuit breaker functions of the 2-6kVA units.

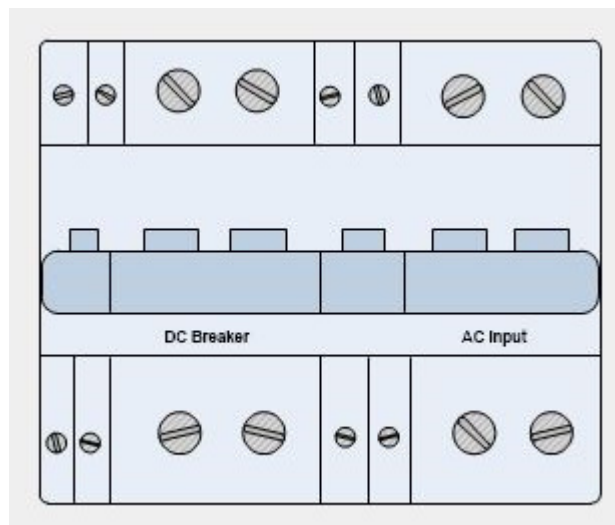

Figure 2-6

2.1.4 Security Plus Terminal Connection Block Illustration (8-15kVA)

All models are factory configured for 50 or 60Hz operation. For the 8-15kVA, the input wires are directly connected to the AC input circuit breaker.

The wire connection (from left to right) of the terminal connection block on the rear is shown below:

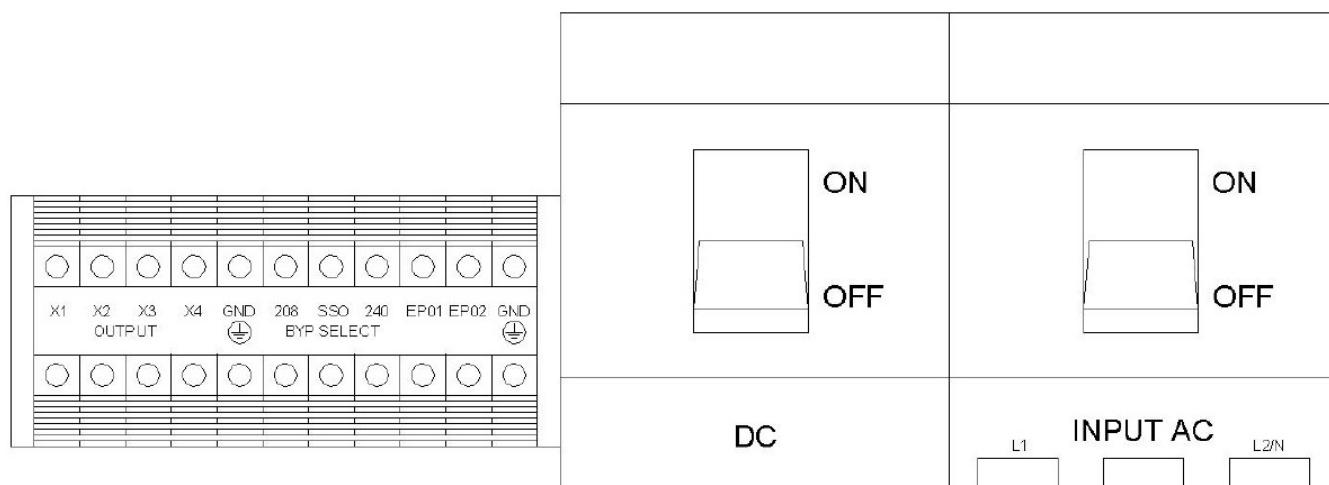

Figure 2-5D

For North American applications, UPS models may be configured for an input voltage of 208 or 240 volts at 60 Hz. Output voltages for these models are available at 120, 208 and 240 volts at 60 Hz. See the table below to connect to the terminal block in Figure 2-5D to achieve the desired input and output voltage configurations.

NORTH AMERICAN CONNECTIONS									
VOLTAGE RATING	INPUT		OUTPUT						BYPASS JUMPER
	VOLTAGE L1 - L2/N	FREQ	VOLTAGE				NEUTRAL	FREQ	
			X1-X4	X1-X3	X3-X4	X2-X4			
208	208	60	240	120	120	208	X3	60	208-SSO
240	240	60	240	120	120	208	X3	60	240-SSO

NOTE: The neutral to ground connection must be properly connected for a 50 or 60 Hz configuration.

For international applications, UPS models may be configured for an input voltage of 200, 220, 230 or 240 volts at 50 Hz. Output voltage for these models matches the input voltage at 50 Hz. See the table below to connect to the terminal block in Figure 2-5B to achieve the desired input and output voltage configurations.

INTERNATIONAL CONNECTIONS									
VOLTAGE RATING	INPUT		OUTPUT						BYPASS JUMPER
	VOLTAGE L1 - L2/N	FREQ	VOLTAGE				NEUTRAL	FREQ	
			X1-X4	X1-X3	X3-X4	X2-X4			
200	200	50Hz	--	--	--	200	X4	50Hz	208-SSO
220	220	50Hz	220	--	--	--	X4	50Hz	240-SSO
230	230	50Hz	230	--	--	--	X4	50Hz	240-SSO
240	240	50Hz	240	--	--	--	X4	50Hz	240-SSO

For field wired units, refer to table 2-4C for the proper conductor size and torque requirements. Only copper conductors are to be used for field wiring connections. The conductors should be rated at least 75°C or greater. The conductor recommendations listed in the chart below are intended for installations in North America. For international installations, please refer to the local and national electrical codes and standards.

RATING	INPUT CONDUCTOR (AWG)		TORQUE (in-lbs)	OUTPUT CONDUCTOR (AWG)		TORQUE (in-lbs)	GROUND (AWG)		TORQUE (in-lbs)
	MIN	MAX		MIN	MAX		MIN	MAX	
8.0kVA	4.0	1.0	62	6.0	4.0	25	6.0	4.0	25
10.0kVA	3.0	1.0	62	6.0	4.0	25	6.0	4.0	25
12.0kVA	2.0	1.0	62	4.0	4.0	25	2.0	2.0	50
15.0kVA	1.0	1.0	62	4.0	4.0	25	2.0	2.0	50

TABLE 2-4C – 8-15kVA CONDUCTOR SIZE AND TORQUE SPECIFICATIONS

Figure 2-7 represents the wiring connections of the 8-10kVA units

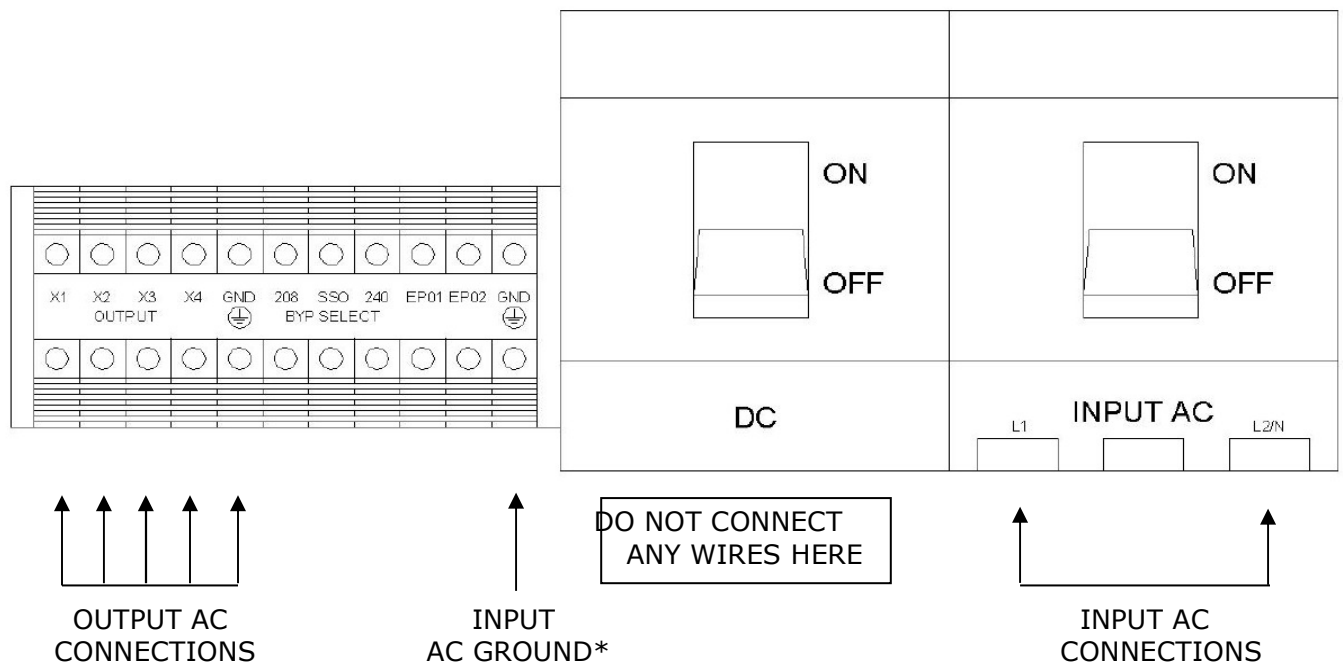

Figure 2-7

- For 12.0 and 15.0kVA all GROUND connections are made directly on the supplied GND terminal attached to the chassis.

All Powervar Hardwired Security Plus UPS system's mains INPUT must be protected by proper sized branch circuit breakers in the building installation. The recommended branch circuit ratings at full rated load are listed below:

ABCDEF2000-11	35 AMP	
ABCDEF3000-11	45 AMP	
	200-208V	220-240V
ABCDEF2000-22	20 AMP	15 AMP
ABCDEF3000-22	25 AMP	20 AMP
ABCDEF4000-22	35 AMP	25 AMP
ABCDEF5200-22	40 AMP	30 AMP
ABCDEF6000-22	45 AMP	35 AMP
ABCDEF8000-22	60 AMP	45 AMP
ABCDEF10.0-22	80 AMP	60 AMP
ABCDEF12.0-22	90 AMP	70 AMP
ABCDEF15.0-22	110 AMP	80 AMP

Refer to local and national electric codes for proper installation guidelines. The breaker recommendations listed in the chart above are intended for installations in North America. For international installations, please refer to the local and national electrical codes and standards.

All Powervar Hardwired Security Plus UPS system's OUTPUT must be protected by proper sized AC disconnect device. The recommended disconnect device ratings at full rated load are listed below:

ABCDEF2000-11	20 AMP
ABCDEF2000-22	10 AMP
ABCDEF3000-11	30 AMP
ABCDEF3000-22	15 AMP
ABCDEF4000-22	20 AMP
ABCDEF5200-22	25 AMP
ABCDEF6000-22	30 AMP
ABCDEF8000-22	50 AMP
ABCDEF10.0-22	65 AMP
ABCDEF12.0-22	80 AMP
ABCDEF15.0-22	100 AMP

2.1.5 RS232 Communications

The pin-out and signals configuration of the RS232 interface is illustrated in Table 2-5



Maximum current carrying capacity of the switch contacts is 3A/30VDC.

RS232 Pin #	Signal Description
1	Not used
2	Transmit data (TXD)
3	Receive data (RXD)
4	AC fail (normally open)
5	Common
6	Battery low (normally open)
7	AC fail (normally closed)
8	Output, AC fail signal (high to low signal)

Table 2-5

2.1.6 Communication Ports Maintenance

The USB communication port on the back panel of the UPS system is designed to communicate with a computer or server. Only connect to this USB port if you intend to use Powervar's monitoring software from a computer or server near the UPS system. The RS232 port is designed to communicate with a computer or server for the same monitoring capabilities. You should only connect to the RS232 port of a computer or server. The remote contact interface port is provided as a set of solid state relay switch contacts. The switches are available through a DB9 male connector on the rear of the UPS. The chart above shows the pin assignment for each signal. The EPO (emergency power off) contact is a normally closed 125 VAC circuit. When wiring to the EPO a properly sized switch must be used. Contact Powervar with any questions

2.2 Basic Principles

When commercial power is normal, UPS input power is routed via the power factor corrected AC to DC chopper circuit. The chopper circuit increases the voltage to $\pm 380V$ stabilized DC voltage, which supplies DC/AC inverter. The inverter changes the DC power back into regulated, conditioned, sinewave AC power, which is connected to the load equipment via a low impedance isolation transformer. At the same time, the battery is kept charged by a battery charger. When commercial power is lost the battery supplies power to the DC buss for use by the inverter. This assures continuous "no break" power for the connected load. In the event of an inverter overload or inverter fault, a solid state static bypass switch automatically connects input power directly to the primary of the output isolation transformer.

UPS operational modes are illustrated in Figures 2-8, 2-9, and 2-10.

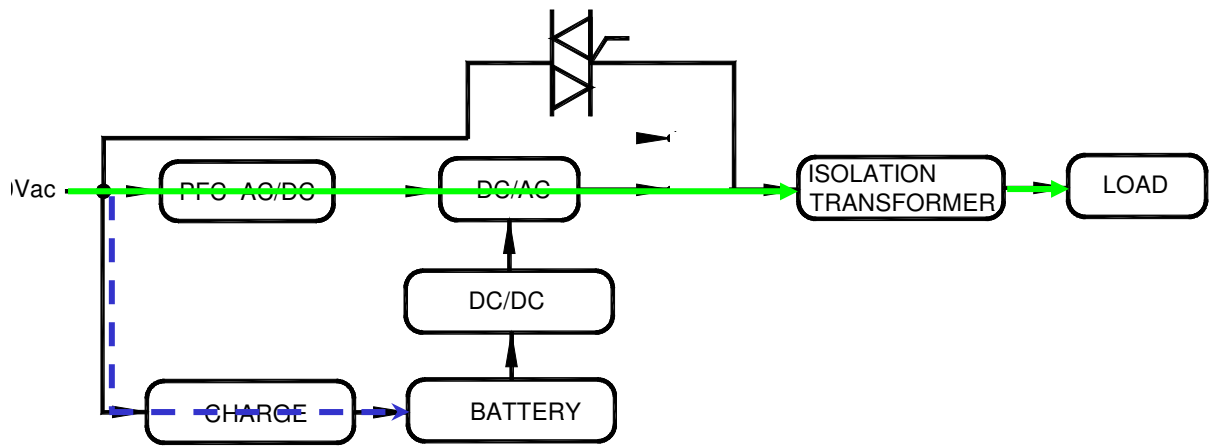

Figure 2-8—Normal Operation Mode

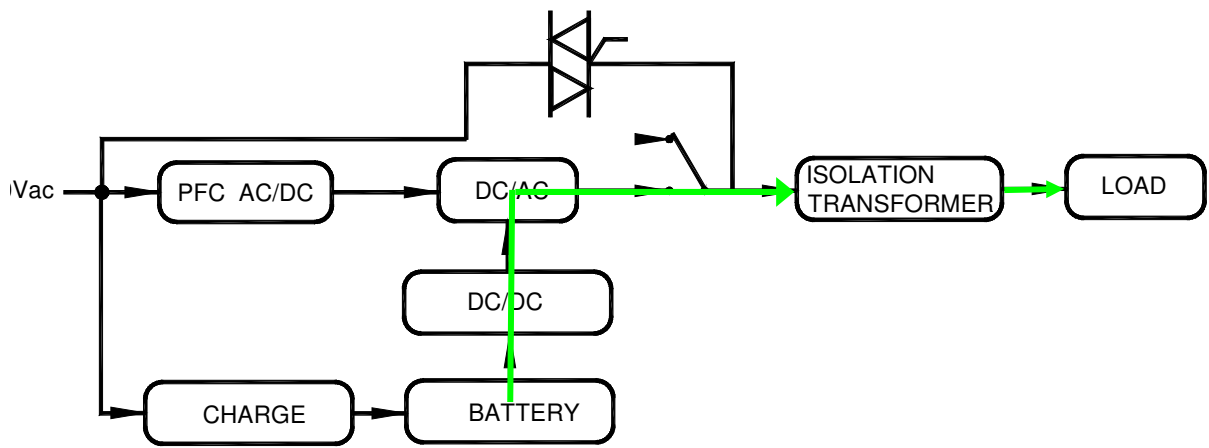

Figure 2-9—Battery Operation Mode

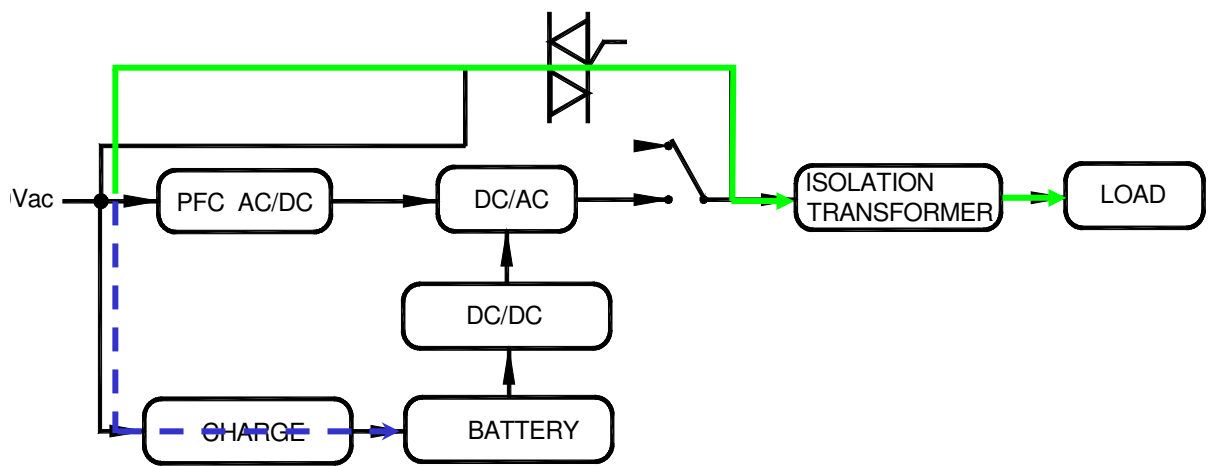

Figure 2-10—Bypass Operation Mode

3.0 Equipment Installation

3.1 Site and Environment Requirements

Before beginning installation of the UPS, the environment where the UPS is to be installed must meet reasonable standards for safe and normal operation as defined in this section. If the installation site conditions do not meet the minimum requirements of safe equipment operation, corresponding changes to the site conditions should be made. Install the equipment only after meeting the conditions of safe and normal equipment operation.

3.1.1 Site Requirements

1. The conditions at the installation site should agree with these guidelines to ensure safe and normal equipment operation.
2. The equipment room must be equipped with appropriate fire prevention and detection devices.
3. The branch electrical circuit supplying power to the UPS should be a dedicated circuit with no other loads connected to it. The circuit should have its own dedicated circuit breaker and (if plug connected) its own dedicated input power receptacle.
4. Do not store flammable or explosive materials in the same room with the UPS.
5. The UPS must be properly grounded to its power supply. The voltage between neutral wire and safety ground on the commercial power input cannot exceed 5V.
6. Ensure that all construction in the installation area is completed prior to installing the UPS. Ensure that the UPS is installed on a hard surfaced floor and the installation site is tidy, dry, and dust-free.
7. The UPS is not supplied with input over-current protection. Reference local and national electric codes for proper input circuit breaker sizing.

3.1.2 Environmental Requirements

Ambient temperature: 0° C to +40° C

Relative humidity: 0% RH to 95% RH, non-condensing

Cooling mode: Forced air cooling

Orientation: Install upright with no more than 5° departure from the vertical plane.

3.2 Procedures for Dismantling Containers

After the equipment is delivered to the installation site, the UPS should be carefully unpacked from the shipping container. Use Figure 3-2 on the next page along with the accompanying un-packaging instructions to remove the UPS from the shipping container. Check the items you have received against the shipping list to ensure you have received all necessary items. Carefully inspect the shipment for any hidden damage. If damage is noted, please contact the freight carrier and request an inspection of the shipping container.

If items are missing from your shipment or if the shipment is not in agreement with your order, contact your distributor or the manufacturer as appropriate.

Note: Do not dispose of any packing materials until the UPS has been inspected, installed, and verified for proper operation.

Security Plus Unpacking Instructions For 2-6kVA Models

The UPS is packed in a heavy duty inner cardboard carton inside a larger plywood shipping container. Both carton and container are securely attached to a heavy duty shipping pallet. The packing materials may be retained for use in shipping the UPS to another location. Should you find it necessary to do so, please observe the correct orientation of the UPS when packing. The side faces of the carton are printed with appropriate packing notices as well as the equipment model number.

Unpacking the UPS requires simple tools such as a screwdriver and an adjustable wrench. To remove the UPS from the shipping container and packing materials, follow these simple steps while referring to Figures 3-2 below.

- 1) The unit has nylon banding on each side of the plywood shipping container which holds the plywood shipping container to the shipping pallet. Remove these nylon bands carefully by cutting them.
- 2) With help from an assistant, raise the plywood shipping container straight up from the pallet until it is clear of the inner cardboard carton.
- 3) Remove any foam packing/cushioning material and save for re-use.
- 4) The plywood assembly on top of the cardboard carton is a ramp for rolling the UPS off the shipping pallet. Remove the plywood ramp and set it to one side.
- 5) Remove the inner cardboard shipping carton and protective plastic cover from the UPS.
- 6) The UPS is attached to the shipping pallet with two shipping brackets – one on each side of the UPS. Using an adjustable wrench or socket set, remove the two bolts that attach the bracket to the UPS. Remove the two bolts that attach the bracket to the shipping pallet. Repeat for the other side of the UPS.
- 7) The UPS has four leveling feet. Be sure to check that the levelers are up against the bottom of the UPM to ensure the UPS rests completely on its four casters.
- 8) Attach the ramp as shown in Figure 3-2. **CAUTION: The lip of the ramp MUST lock into position under top surface of pallet for SAFETY.** With the help from an assistant, carefully roll the UPS off the pallet and down the ramp to the floor of your facility. The UPS may now be easily moved on its casters to the installation location.

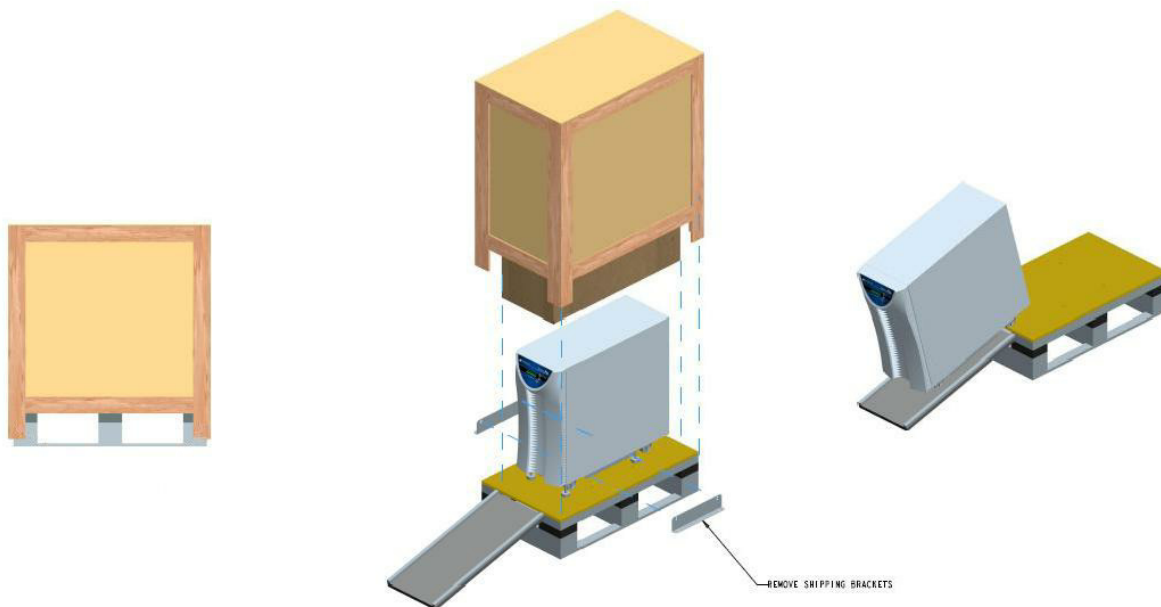

Figure 3-2

Security Plus Unpacking Instructions For 8-15kVA Models

The UPS is packed in a heavy duty cardboard carton. The carton is securely attached to a heavy duty shipping pallet. The packing materials may be retained for use in shipping the UPS to another location. Should you find it necessary to do so, please observe the correct orientation of the UPS when packing. The side faces of the carton are printed with appropriate packing notices as well as the equipment model number.

Unpacking the UPS requires simple tools such as a screwdriver and an adjustable wrench. To remove the UPS from the shipping container and packing materials, follow these simple steps while referring to Figures 3-3 below.

- 9) On each side of the cardboard carton there are two bolts (four bolts total) which attach the cardboard carton to the shipping pallet. Remove these four bolts and save them, if necessary, for re-use later.
- 10) With help from an assistant, raise the cardboard carton straight up from the pallet until it is clear of the unit packaging and ramp.
- 11) The plywood assembly inside of the cardboard carton is a ramp for rolling the UPS off the shipping pallet. Remove the plywood ramp and set it to one side.
- 12) Remove any foam packing/cushioning material and save for re-use.
- 13) Remove the protective plastic cover from the UPS.
- 14) The UPS is attached to the shipping pallet with two shipping brackets – one on each side of the UPS. Using an adjustable wrench or socket set, remove the two bolts that attach the bracket to the UPS. Remove the two bolts that attach the bracket to the shipping pallet. These bolts should be set aside to secure the ramp to the pallet. Repeat for the other side of the UPS.
- 15) The UPS has four leveling feet. Be sure to check that the levelers are up against the bottom of the UPS to ensure the UPS rests completely on its four casters.
- 16) Attach the ramp as shown in Figure 3-3. The bolts used to attach the shipping brackets should be used to secure the ramp to the pallet. **CAUTION: The ramp brackets must align with the holes in the pallet and be secured by the bolts for SAFETY.** With the help from an assistant, carefully roll the UPS off the pallet and down the ramp to the floor of your facility. The UPS may now be easily moved on its casters to the installation location.

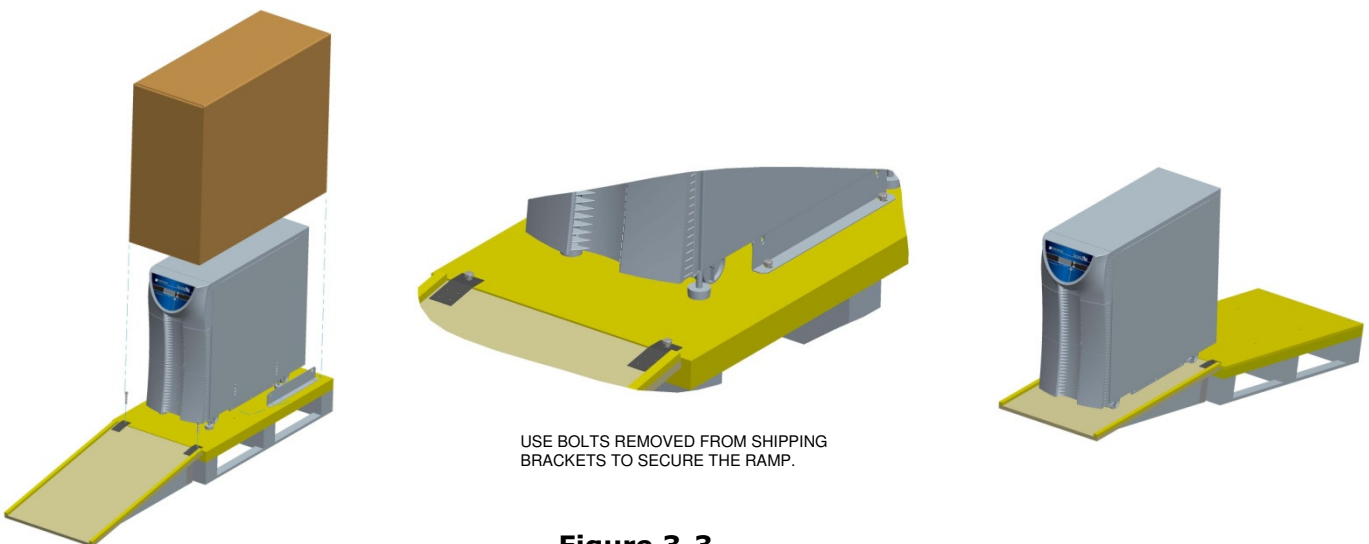
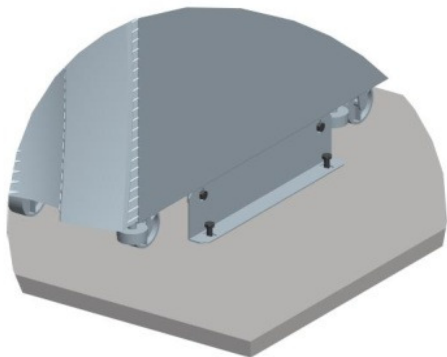

Figure 3-3

3.3 Installation of UPS

For convenient operation, maintenance, and cooling of the equipment, there should be at least 30cm to 50cm (approximately 12" to 20") of free space around the UPS enclosure and 50cm (approximately 20") above the UPS enclosure. Be careful that vent openings and UPS fans are kept clear and free of obstructions to ensure good interior ventilation. Ensuring unobstructed flow of cooling air will also improve battery reliability as the battery's service life will be maximized when the battery is used under normal temperature (20° C). It is always preferable to have the UPS installed in an air-conditioned environment. Follow all precautions for installation and use of the UPS.

1. Place UPS on a smooth and level floor. Allow no more than 5° departure from vertical to ensure the UPS cannot tip over resulting in injury or damage.
2. Ensure good ventilation by observing the recommended spacing requirements at the back sides and top of the unit.
3. Avoid installing the UPS in direct sunlight.
4. Protect the UPS from humidity and moisture.
5. Never store corrosive, flammable, or explosive substances in the room with the UPS.
6. Do not place articles on or around the UPS. Ensure that ventilation slots and openings are not blocked.
7. Do not allow people to sit on the UPS.
8. The mounting brackets are not seismic; the UPS system should be mounted in place to the building structure flooring prior to operation.
9. To secure the base of the UPS to the flooring, bond the mounting brackets to each side of the UPS base and flooring using the screws provided.



USE FOUR M8 OR 5/16 BOLTS TO SECURE THE TWO MOUNTING BRACKETS TO FLOOR.

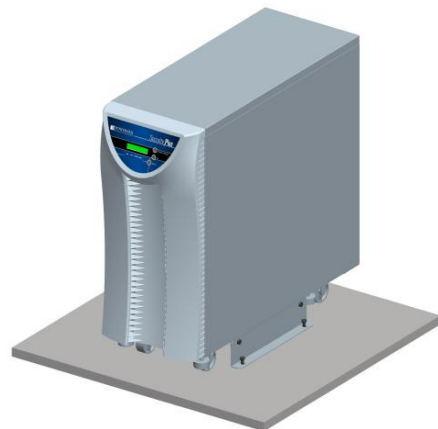

4.0 Equipment Use and Maintenance

4.1 Preparation for Start-up

To ensure proper operation of the UPS, please confirm the following before use:

1. Correct installation of input and output wiring connections. (See section 2.1.3 or 2.1.4)
2. Please verify the UPS is setup for the correct voltage. The label on the rear of the unit will indicate the factory input voltage setting. If you need to change the input voltage setting please reference section 2.1.3 or 2.1.4.
3. Input voltage matches the configuration selected in #2 above.
4. The battery circuit breaker on the rear of the UPS is in the "OFF" position.
5. Confirm that computers, instrumentation or other connected loads are turned off



Do not connect loads with high, non-linear current demands (such as laser printers) to the UPS. Do not connect loads with AC motors (such as vacuum cleaners) to the UPS.

4.2 Routine UPS Startup Sequence

After confirming all the above, you are ready to start the UPS.

1. Turn the main input circuit breaker on the back of the UPS to the **ON** position. (See table 2-2).
2. Turn the battery circuit breaker to the **ON** position. (See table 2-2).
3. The line indicator light will turn on when AC is applied. After a short delay the **INV** light will turn on if the AC input is within specification. The UPS is now operating normally and is capable of supplying uninterruptible power. (See figure 2-1).
4. If any other conditions is displayed reference the trouble section of the manual (Section 4.5 and 4.6).
5. Start the connected loads in sequence with highest power loads being started first and lower power loads being started last.

4.3 Routine UPS Shutdown

1. Press the **NORMAL/BYPASS** button on the UPS panel to stop the UPS inverter. After stopping the inverter, the UPS will be in bypass mode (See figure 2-1).
2. Turn off the main circuit breaker (See table 2-2).
3. Turn off the battery circuit breaker (See table 2-2).
4. To once again start the UPS, follow the instructions for routine start-up as already discussed.

4.4 Important Battery Issues

If the UPS has been disconnected for a long period, it should be charged for at least four hours before operation can resume. While it is possible to use the UPS during this charging period, it is important to keep in mind that if a power outage occurs, battery runtime may be quite short.



As long as the UPS is connected to a live power source and the UPS input circuit breaker and battery circuit breaker is turned on, the UPS battery will be kept in a charged state.

1. Batteries of different capacity, type, and brand should not be used together. The manufacturer has approved only the type, capacity, and brand of battery originally shipped with the UPS. Please consult the UPS manufacturer before replacing batteries with any batteries not meeting these specifications.
2. When cleaning the outside of the UPS use only a soft cloth and clear water. Do not use oily substances, solvents, or abrasive cleaners, etc.
3. The UPS should be kept away from ignition sources as well as all electrical equipment that may cause sparks.
4. Be careful not to store flammable, explosive, or corrosive substances in the same area as the UPS or any add-on battery cabinets.
5. If the UPS is routinely disconnected for long periods, be sure to regularly connect the UPS and charge the battery to prevent battery damage as the result of self-discharging.

4.5 Frequent Trouble Causes

If the UPS fails to work properly after installation and start-up, please don't automatically assume that a UPS failure has occurred. Please refer to the following steps to try to identify a possible cause.

Problem 1

Main supply and output are normal after start-up but the alarm buzzer is sounding intermittently.

Possible cause: Unstable AC power input as a result of poor input connections at a breaker, wall receptacle, or UPS terminal block.

Solution: Check all input power connections.

Problem 2

After UPS is started, the output voltage is normal, but the UPS is in bypass mode (**BYPASS** light illuminated).

Possible cause: Too much load is connected to the UPS.

Solution: Remove or turn off connected loads in increments until the **BYPASS** light is extinguished. If UPS is overloaded, it may be necessary to install an additional UPS or one with a higher capacity rating.



(Note: Some bypass operations are caused as a result of starting up high inrush loads. In such cases, bypass operation will be temporary, and the UPS will return to normal operation as soon as load inrush current subsides.)

Problem 3

UPS displays and UPS output are normal after start-up. However, the output stops as soon as load is connected to it.

Possible cause #1: UPS is experiencing a severe overload or a circuit short circuit on the output.

Solution: Reduce the load to an adequate amount, or check loads to locate a short circuit. In many cases, short circuits are caused by shorted output adapters or damaged load equipment.

Possible cause #2: Failure to follow the proper load start-up sequence.

Solution: Restart the UPS with no output loads turned on. Then power on the largest loads first and then smallest loads last.

Problem 4

The UPS works properly after start-up, and automatically shuts off after a certain period of time.

Possible cause: The UPS is running on battery (either not powered by AC input or not connected to AC input) and the battery is not fully charged.

Solution: Immediately turn off all switches, and restart the UPS. Verify that AC power is present to the UPS input and that the UPS is operating normally. Charge the battery for a minimum of four hours (preferably to full capacity) before returning to use. Note: Long-period low voltage of the battery will shorten the service life of the battery.



Long term low voltage of the battery will shorten its service life.

Problem 5

After working for a certain period, with a normal input display, the buzzer gives intermittent buzzing and displays battery low voltage simultaneously.

Possible cause: Input power supply has very low voltage causing the UPS work from its battery. When the battery runs low, a low voltage battery condition occurs and the UPS enters into protection status.

Solution: Determine cause of very low input voltage.

Problem 6

UPS is started and working. When a power outage occurs, the UPS fails to output power.

Possible cause: The battery is not connected to the UPS, the battery circuit breaker is open (turn off), or the battery itself is severely damaged.

Solution: Verify that the UPS battery is properly connected, the battery circuit breaker is closed (turned on) and that the battery itself is not damaged or defective.

Problem 7

If the "LINE" LED is flashing and the buzzer gives an intermittent alarm, this is alerting the user of a Ground fault. The alarm works by checking for a neutral to ground bond. If the network is unpolarized or has no neutral to ground bond follow the solution below.

Solution:

- 1) Press and hold the SELECT button until the screen displays "Inverter Off: Yes?"
- 2) Press SELECT button two more times until screen displays "Ground Fault: Disable?"
- 3) Press OK
- 4) Press the NORMAL/BYPASS button and wait 2 minutes (It is important to wait the 2 minutes).
- 5) Press the NORMAL/BYPASS button again.
- 6) Check to insure the LINE and INV LEDS are on.

4.6 Troubleshooting

4.6.1 Overview

In the event of UPS failure, first inspect the UPS and the area around it to determine if there are any obvious reasons for malfunction. Check for external factors such as high temperature or humidity. Check to make sure that the UPS ventilation slots and holes are not obstructed. Carefully observe any messages that may appear in the display window on the front panel of the UPS.



Only simple troubleshooting suggestions are provided here. If you cannot arrive at a clear diagnosis of the problem using the information here or if the information given here is not sufficient to solve your problem, please contact your distributor or the manufacturer for assistance and repair.

4.6.2 Troubleshooting Steps

Problem: Buzzer gives long buzzing, fault light is on, UPS is powered through bypass, and inverter fails.

Possible cause 1: Output overload or short circuit results in UPS automatic shutdown protection.

Solution: Locate and remove source of overload or short circuit

Possible cause 2: Driver or power transistor failure

Solution: Contact distributor or manufacturer

Possible cause 3: Master control board failure.

Solution: Contact distributor or manufacturer

Possible cause 4: UPS Over-temperature protection

Solution: Turn off all loads. Allow UPS to cool down and restart UPS according to routine start-up instructions.

Problem: UPS works properly when power supply is O.K., but it fails to function during power failure.

Possible cause 1: Battery circuit breaker is open (Off)

Solution: Close (turn on) battery circuit breaker

Possible cause 2: Battery failure

Possible cause 3: Battery charger malfunction

Possible cause 4: Poor contact between battery connecting wires or connecting terminals.

Solution: Contact distributor or manufacturer

Problem: Intermittent buzzing of the buzzer when UPS input is normal.

Possible cause: Abnormal input voltage that exceeds the UPS' acceptable input voltage range for the mains power supply.

Solution: Contact electrician to verify state of input voltage to UPS

Problem: UPS works well when computer is in operation. After power failure, UPS works properly but the connected load crashes.

Possible cause: Neutral to ground voltage at UPS input is too high.

Solution: Contact electrician to correct excessive input neutral to ground voltage.

Problem: All of panel indicator lamps are off.

Possible cause: Poor connection or malfunction of display control panel.

Solution: Contact distributor or manufacturer.

5.0 Battery Tray Replacement

5.1 Precautions

Servicing of batteries should be performed or supervised by personnel knowledgeable about batteries and the required precautions. (Please contact Powervar for Battery Replacement)

When replacing batteries, replace with the same type and number of batteries or battery packs.

CAUTION: Risk of explosion if battery is replaced by incorrect type.
Dispose of used batteries according to the instructions.

CAUTION: Do not dispose of batteries in a fire. The batteries may explode.

CAUTION: Do not open or mutilate batteries. Released electrolytes are harmful to the skin and eyes. It may be toxic.

CAUTION: A battery can present a risk of electrical shock and high short-circuit current. The following precautions should be observed when working on batteries:

- a) Remove watches, rings, or other metal objects.
- b) Use tools with insulated handles.
- c) Wear rubber gloves and boots.
- d) Do not lay tools or metal parts on top of the batteries.
- e) Disconnect charging source prior to connecting or disconnecting battery terminals.
- f) Determine if the battery is inadvertently grounded. If inadvertently grounded, remove source from ground. Contact with any part of a grounded battery can result in electrical shock. The likelihood of such shock can be reduced if such grounds are removed during installation and maintenance (applicable to equipment and remote battery supplies not have a grounded supply circuit).

5.1.1 Battery Tray Replacement (2-6kVA)

Reference Fig. 5-1 for the following steps.

1. Flip the DC circuit breaker on the rear panel of the UPS to the **OFF** position.
2. Remove the front plastic panels of the UPS.
3. With a screwdriver, remove the metal front panel and the securing bars

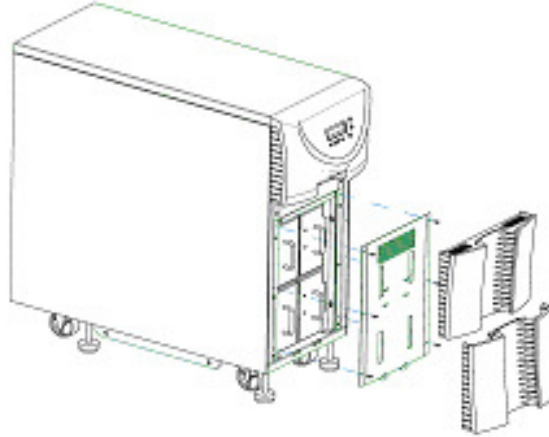

Fig. 5-1

Reference Fig. 5-2 for the following steps.

4. Pull out battery tray (1), then tray (2), then tray (3), then tray (4) out of the unit
5. Position detached battery trays away from one another when servicing
6. Slide the new Powervar battery trays into the empty slots
7. Battery cables are located in between the battery trays. Examine all battery connections to ensure that there are no loose or damaged connections prior to connecting battery trays.
8. Make sure the trays are secure and connected to the connection socket
9. Place the metal bars, panels, and plastic covers back on the unit
10. Battery connectors extend past the front of the battery trays. Examine all battery connectors to ensure that there is clearance between the connections and the cover plate before installing cover panels.
11. Secure these components back in place with appropriate hardware
12. Flip the DC circuit breaker on the rear panel of the UPS to the **ON** position

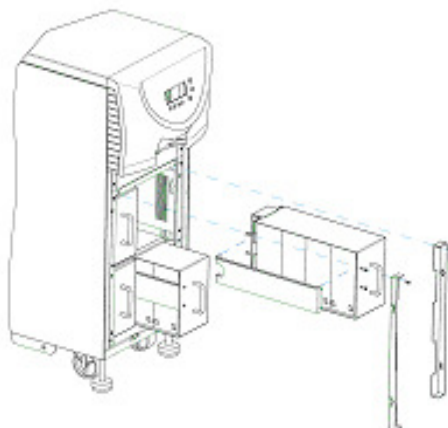

Fig. 5-2

5.1.2 Battery Tray Replacement (2-6kVA)

Reference Fig. 5-3 for the following steps:

1. Flip the DC circuit breaker on the rear panel of the UPS to the **OFF** position.
2. Open the lower front door of the UPS.
3. With a screwdriver, remove the metal front panel.

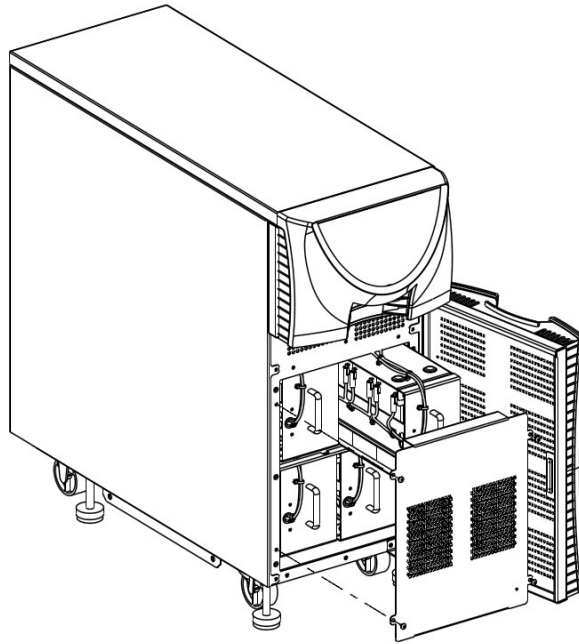

Fig. 5-3

CAUTION: Battery connectors extend past the front of the battery trays. Examine all battery connections prior to removing the front cover panel.

1. Unplug the desired battery tray connector from the front of the unit.
2. Lift the front of the tray and pull the tray out straight.
3. Lift the rear of the tray to remove the tray from the battery compartment.
4. Repeat steps 2-4 for additional battery trays.
5. Slide the new Powervar battery trays into the empty slots.
6. Make sure the trays are secure and re-connect the battery tray connectors in the front of the unit.
7. Secure these components back in place with appropriate hardware.
8. Flip the DC circuit breaker on the rear panel of the UPS to the **ON** position.

CAUTION: Battery cables are located outside the battery trays. Examine all battery connections to ensure that there are no loose or damaged connections prior to connecting battery trays.

CAUTION: Battery connectors extend past the front of the battery trays. Examine all battery connectors to ensure that there is clearance between the connections and the cover plate before installing cover panels.

5.1.3 Battery Tray Replacement (8-15kVA)

Reference Fig. 5-4 for the following steps:

1. Flip the DC circuit breaker on the rear panel of the UPS to the **OFF** position.
2. Open the lower front door of the UPS.
3. With a screwdriver, remove the metal front panel.

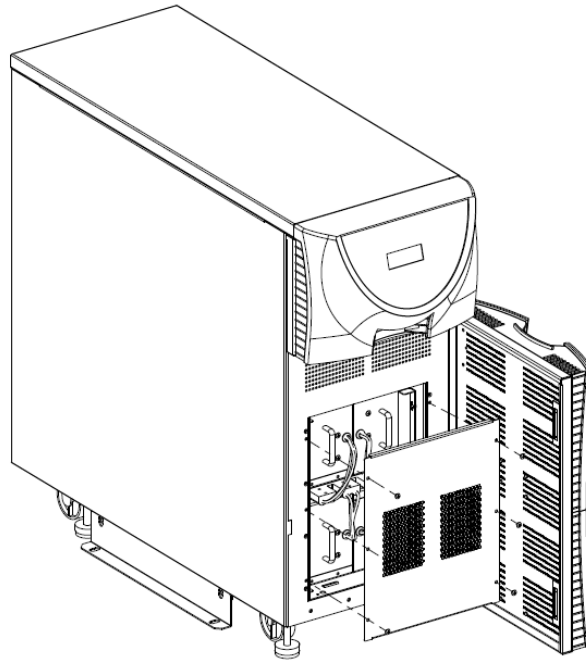

Fig. 5-4

CAUTION: Battery connectors extend past the front of the battery trays. Examine all battery connections prior to removing the front cover panel.

1. Remove the battery retaining brackets.
2. Unplug the desired battery tray connector from the front of the unit.
3. Lift the front of the tray and pull the tray out straight.
4. Lift the rear of the tray to remove the tray from the battery compartment.
5. Repeat steps 2-4 for additional battery trays.
6. Slide the new Powervar battery trays into the empty slots.
7. Make sure the trays are secure and re-connect the battery tray connectors in the front of the unit.
8. Replace the metal bars on the unit.
9. Secure these components back in place with appropriate hardware.
10. Flip the DC circuit breaker on the rear panel of the UPS to the **ON** position.

CAUTION: Battery cables are located in between the battery trays. Examine all battery connections to ensure that there are no loose or damaged connections prior to connecting battery trays.

CAUTION: Battery connectors extend past the front of the battery trays. Examine all battery connectors to ensure that there is clearance between the connections and the cover plate before installing cover panels.

6.0 Packing, Transportation and Storage

6.1 Packing

The original shipping container for the UPS consists of a heavy duty inner cardboard carton inside a larger plywood shipping container both of which are securely fastened to a shipping pallet. Should you find it necessary to ship the UPS for service or installation, you should attempt to re-use this original packaging material along with the shipping brackets that originally accompanied the UPS. Follow these simple steps to prepare the UPS for shipment. (Consult Fig. 3-2 on page 26 for visual guidance.)

1. Place the UPS on the shipping pallet.
2. Attach a metal shipping bracket to each side of the UPS frame at the lower edge of the UPS near the shipping pallet. There are two bolt holes in the UPS frame on each side of the UPS for attaching the shipping bracket.
3. Bolt the shipping brackets to the shipping pallet on each side of the UPS by passing bolts through both holes of the shipping bracket and through the shipping pallet on both sides of the UPS. Secure these bolts with flat washers, lock washers, and nuts.
4. Cover the UPS with the protective plastic bag.
5. Place the foam shipping inserts in appropriate places on the UPS and then slide the heavy cardboard container over the UPS.
6. Place the plywood ramp on top of the cardboard container.
7. Place the outer plywood shipping container over the UPS and cardboard inner container, and secure the plywood shipping container to the shipping pallet using two screws on each side of the pallet.

6.2 Transportation

Handle the UPS with care. Avoid violent impact or dropping of the shipping carton. During transportation, be careful to observe packing and shipping notices printed on the sides of the shipping carton. Do not stack

6.3 Storage

The UPS should always be stored in a dry location. Do not expose it to moisture or rain. Be careful to observe storage notices printed on the side of the shipping carton. Store it where the ambient temperature is between 0° C and 55° C and relative humidity is between 20% and 80%. No harmful gases, corrosive chemicals, flammable or explosive materials should be kept in the storage area with the UPS. The storage environment must be free from strong mechanical vibration, impact, and intense magnetic fields. If not otherwise specified, the storage period of the UPS under the required conditions of this clause is 6 months. During long-term storage, charge the storage battery every 3 months to prevent battery damage due to self discharge.

6.4 Fuse Replacements

The servicing of any fuses in a Security Plus UPS system should be performed by an authorized and qualified service technician. When replacing a fuse, it is imperative that the replacement fuse is the same type and rating. Charger PCB fuses: F1, F2: are a 250V, 5.0 amp fuse. The control PCB fuse is a 125V, 0.25 amp fuse. In the 2kVA and 4kVA UPS systems; the Power PCB uses a 250V, 2.0 amp fuse in F1, a 250V, 20.0 amp fuse in F2, and a 250V, 15.0 amp fuse (Littelfuse 314 Series) in F4 and F5. In the 3kVA, 5.2kVA, and 6kVA UPS systems; the Power PCB uses a 250V, 2.0 amp fuse in F1, a 250V, 25.0 amp fuse in F2, and a 250V, 20.0 amp fuse (Littelfuse 314 Series) in F4 and F5.

7.0 Mechanical Characteristics

7.1 Unit Dimensions/Weights

Model	Height in/mm	Width in/mm	Depth in/mm	Unit Weight lbs/kg
ABCDEF2000-11	28.7/735.5	11.8/299.72	32.65/829.3	215/97
ABCDEF2000-22	28.7/735.5	11.8/299.72	32.65/829.3	221/100
ABCDEF3000-11	28.7/735.5	11.8/299.72	32.65/829.3	294/132
ABCDEF3000-22	28.7/735.5	11.8/299.72	32.65/829.3	300/135
ABCDEF4000-22	28.7/735.5	11.8/299.72	32.65/829.3	317/143
ABCDEF5200-22	28.7/735.5	11.8/299.72	32.65/829.3	348/157
ABCDEF6000-22	28.7/735.5	11.8/299.72	32.65/829.3	348/157
ABCDEF8000-22	35.5/850.0	13.8/349.76	38.6/980.6	449.0/203.7
ABCDEF10.0-22	35.5/850.0	13.8/349.76	38.6/980.6	449.0/203.7
ABCDEF12.0-22	42.3/1080.2	15.75/400.0	44.39/1127.54	719.0/326.1
ABCDEF15.0-22	42.3/1080.2	15.75/400.0	44.39/1127.54	739.0/335.2

7.2 Shipping Dimensions/Weights

Model	Height in/mm	Width in/mm	Depth in/mm	Shipping Weight lbs/kg
ABCDEF2000-11	44.0/1117.6	23.25/590.55	38.5/977.9	310/139
ABCDEF2000-22	44.0/1117.6	23.25/590.55	38.5/977.9	316/142
ABCDEF3000-11	44.0/1117.6	23.25/590.55	38.5/977.9	389/175
ABCDEF3000-22	44.0/1117.6	23.25/590.55	38.5/977.9	395/178
ABCDEF4000-22	44.0/1117.6	23.25/590.55	38.5/977.9	412/185
ABCDEF5200-22	44.0/1117.6	23.25/590.55	38.5/977.9	443/200
ABCDEF6000-22	44.0/1117.6	23.25/590.55	38.5/977.9	443/200
ABCDEF8000-22	56.5/1435.1	25.25/641.35	45.25/1149.35	641.5/291
ABCDEF10.0-22	56.5/1435.1	25.25/641.35	45.25/1149.35	641.5/291
ABCDEF12.0-22	60.2/1530.0	20.1/510.0	48.4/1230.0	807.0/366.0
ABCDEF-15.0-22	60.2/1530.0	20.1/510.0	48.4/1230.0	807.0/366.0

8.0 Warranty

8.1 Basic Warranty

Security Plus Series products (hereafter referred to as "Product") are warranted to be free from defects in material and workmanship for **three (3) years** from date of shipment from Powervar, on the chassis & electronic components and **two (2) years** from date of shipment from Powervar on the batteries. This warranty is limited to repairing, replacing, or refurbishing, at Powervar's option, any defective component, circuit board or module within the Product. For Products 3 kVA and below located anywhere, this warranty is limited to Powervar depot service. For Products above 3 kVA located in the continental United States, United Kingdom or Germany, this warranty will include, at Powervar's sole discretion, on-site service or Powervar depot service. For locations other than those specified herein, this warranty is limited to Powervar depot service. See the Limitations of Warranty section below for additional limitations & exclusions.

8.2 Limitations

This limited warranty does not cover any losses or damage resulting from shipment to or from the Customer, or from improper installation, improper application, inappropriate environment, abuse, neglect, unauthorized modifications, adjustments, or repair of the Product. Additionally, any costs related to installation or de-installation of the Product for the purpose of replacement or servicing will be the Customer's sole responsibility. Powervar makes no warranties, expressed or implied, of merchantability, fitness for a particular purpose, performance, condition, capacity, or otherwise. Powervar is not liable for incidental or consequential damages, monetary loss, loss of sales, or loss of business resulting from the failure or malfunction of the Product. Warranty is void on Product where evidence of tampering exists. Improper long-term storage may damage the UPS batteries and invalidate the battery warranty. Disconnecting a UPS from its AC utility power source for an extended period of time results in lost battery charge. To keep the batteries fully charged and maximize the life of the batteries, connect the UPS to an AC power source while it is in storage. If this is not possible, the UPS must be connected to a power source for 24 hours at least once every 4 months, or every 2 months if the ambient temperature is more than 30°C (86°F). Additionally, Powervar's warranty on batteries applies only to Products that are continuously connected to AC mains power, except during utility power outages. Products that are regularly and intentionally disconnected from AC mains power will experience battery discharge/charge cycles that are potentially far more numerous than those for which the battery was designed. As a result, Products used in such applications will experience substantially reduced battery life.

Therefore, Powervar's standard warranty term does not apply in these cases and is supplanted by a **90 day** warranty from time of shipment from Powervar. The warranty provided by Powervar provides for the replacement of the battery or battery systems in the event that the batteries do not meet the performance specifications as determined by Powervar exclusively. All warranty services will be performed during Powervar normal, non-holiday business hours (Monday through Friday, 8:00 AM – 5:00 PM CST). Any service required by Customer to be performed outside of normal business hours will be subject to Powervar's prevailing labor rates.



A01-00109 Rev. B 5/11/2018



USA Address:

1450 Lakeside Drive
Waukegan, IL 60085

1-800-369-7179
(F) 847-596-7100

Canada Address:

700 Finley Avenue, Unit 3 Ajax, Ontario
L1S 3Z2

(P) 905-239-9284

Europe/Asia Address:

Unit 5, Birch-Kembrey Park
Swindon, Wilts SN2 8UU UK

(P) +44 1793 553980
(F) +44 1793 535350

Mexico Address:

Camino a la Montana
No. 178-101 & PB4
Fracc. Industrial La Perla,
53340 Naucalpan, Edo De Mexico

(P) (52) 55 5363 5448