

# Operating instructions

UNIVERSAL 320 / 320 R



Translation of the original operating instructions



---

©2022 – All rights reserved

Andreas Hettich GmbH & Co. KG

Föhrenstrasse 12

D-78532 Tuttlingen, Germany

Telephone: +49 (0)7461 705-0

Fax: +49 (0)7461 705-1125

Email: [info@hettichlab.com](mailto:info@hettichlab.com), [service@hettichlab.com](mailto:service@hettichlab.com)

Internet: [www.hettichlab.com](http://www.hettichlab.com)

## Table of contents

<b>1</b>	<b>About this document.</b>	<b>5</b>
1.1	Use of this document.	5
1.2	Gender reference.	5
1.3	Symbols and labels in this document.	5
<b>2</b>	<b>Safety.</b>	<b>5</b>
2.1	Intended use.	5
2.2	Personnel requirements.	6
2.3	Operator's responsibility.	7
2.4	Safety instructions.	7
<b>3</b>	<b>Device overview.</b>	<b>9</b>
3.1	Technical data.	9
3.2	European registration.	12
3.3	Important labels on the packaging.	13
3.4	Important labels on the device.	13
3.5	Operating and indicator elements.	14
3.5.1	Control.	14
3.5.2	Indicator elements.	15
3.5.3	Controls.	15
3.6	Original spare parts.	15
3.7	Scope of delivery.	16
3.8	Returns.	16
<b>4</b>	<b>Transport and storage.</b>	<b>16</b>
4.1	Transport and storage conditions.	16
4.2	Fastening the transport lock.	17
<b>5</b>	<b>Commissioning.</b>	<b>18</b>
5.1	Unpacking the centrifuge.	18
5.2	Removing the transport lock.	18
5.3	Setting up and connecting the centrifuge.	19
5.4	Switching the centrifuge on and off.	21
<b>6</b>	<b>Operation</b>	<b>21</b>
6.1	Opening and closing the lid.	21
6.2	Removing and installing the rotor.	22
6.3	Inserting and removing buckets.	24
6.4	Inserting and removing adapters.	24
6.5	Loading.	25
6.6	Opening and closing the biosafety system.	27
6.6.1	Explanation.	27
6.6.2	Lid with screw cap and hole	28
6.6.3	Lid with bracket and spring-type lock.	28
6.6.4	Lid with screw cap.	29

6.7	Centrifugation. . . . .	29
6.7.1	Centrifugation in continuous operation. . . . .	29
6.7.2	Centrifugation with time preselection. . . . .	30
6.7.3	Short-time centrifugation. . . . .	30
6.8	Quick stop function. . . . .	30
<b>7</b>	<b>Software operation. . . . .</b>	<b>31</b>
7.1	Centrifugation parameters. . . . .	31
7.1.1	Relative centrifugal force, RCF. . . . .	31
7.1.2	Centrifugation of substances or mixtures of substances with a density higher than 1.2 kg/dm <sup>3</sup> . . . . .	31
7.2	Programming. . . . .	32
7.2.1	Write protection for programs. . . . .	32
7.2.2	Opening or loading programs. . . . .	32
7.2.3	Entering or changing programs. . . . .	32
7.3	Rotor detection. . . . .	33
7.4	Cooling (for centrifuges with cooling). . . . .	33
7.4.1	Instructions, cooling. . . . .	33
7.4.2	Standby cooling. . . . .	33
7.4.3	Precooling the rotor. . . . .	33
7.5	Machine Menu. . . . .	34
7.5.1	Querying system information. . . . .	34
7.5.2	Querying operating hours. . . . .	34
7.5.3	Audible signal. . . . .	35
7.5.3.1	General. . . . .	35
7.5.3.2	Setting an audible signal. . . . .	35
<b>8</b>	<b>Cleaning and care. . . . .</b>	<b>35</b>
8.1	Overview table. . . . .	35
8.2	Instructions for cleaning and disinfection. . . . .	36
8.3	Cleaning. . . . .	36
8.4	Disinfection. . . . .	37
8.5	Maintenance. . . . .	38
<b>9</b>	<b>Troubleshooting. . . . .</b>	<b>39</b>
9.1	Fault description. . . . .	39
9.2	Performing a MAINS RESET. . . . .	40
9.3	Emergency release. . . . .	41
<b>10</b>	<b>Disposal. . . . .</b>	<b>41</b>
10.1	General instructions. . . . .	41
<b>11</b>	<b>Index. . . . .</b>	<b>43</b>

## 1 About this document

### 1.1 Use of this document

- Read this document carefully and in full before commencing initial operation of the device.  
Observe other enclosed instruction sheets where necessary.
- This document constitutes part of the device and must be kept within easy reach.
- This document must be included if the device is passed on to a third party.
- The most recently updated version of this document in the available languages can be found on the manufacturer's website at: ➔ <https://www.hettichlab.com/de/download-center/>

### 1.2 Gender reference

The employed masculine or feminine language form is to facilitate reading. In the spirit of equal treatment, corresponding terms apply in principle to all genders and do not imply any valuation.

### 1.3 Symbols and labels in this document

#### General symbols

The following markers are used in this document to highlight instructions, results, listings, references and other elements:

Marker	Explanation
1. 2. 3. ...	Step-by-step instructions
	Results of action steps
	References to sections of the document and other applicable documents
■ ... ■ ...	Listings without a fixed order
<i>[Buttons]</i>	Controls (for example: buttons, switches)
<i>'Indicator'</i>	Indicator elements (for example: signal lights, screen elements)

## 2 Safety

### 2.1 Intended use

#### Intended use

The centrifuge **UNIVERSAL 320 / 320 R** is an in vitro diagnostic medical device in accordance with the In Vitro Diagnostic Medical Devices Regulation (EU) 2017/746. The device is used for centrifugation as well as enrichment of sample material of human origin for subsequent further processing for diagnostic purposes. The user can set each of the variable physical parameters within the limits set by the device.

The centrifuge may only be used by qualified personnel in closed laboratories. The centrifuge is only intended for the use referred to above. Intended use also includes observing all instructions in the user manual and compliance with inspection and maintenance. Any other use or use beyond this is considered improper. Andreas Hettich GmbH & Co. KG shall not be liable for any damage arising from this.

#### Non-intended use

- The centrifuge is not suitable for use in explosive or radioactive, or biologically or chemically-contaminated atmospheres.
- The user must take appropriate actions when centrifuging hazardous substances or mixtures of substances that are toxic, radioactive or contaminated with pathogenic microorganisms.  
The manufacturer generally recommends using only centrifuge tubes with special screw caps designed for use with hazardous substances. Use sealable centrifuge tubes with a biosafety system for materials of risk groups 3 and 4.
- The manufacturer does not recommend centrifugation of flammable or explosive materials.
- The manufacturer does not recommend centrifugation of materials that react chemically with one another with high activation energy.

#### Foreseeable misuse

The manufacturer recommends using only accessories approved that it has approved for the intended purpose.

Only operate the centrifuge under supervision.

## 2.2 Personnel requirements

#### Required qualifications

The user has read the Operating Manual in full and familiarised themselves with the device.



#### NOTICE

##### Damage to the device by unauthorised personnel

- Tampering with and modifications to devices by unauthorised persons are at the operating organisation's own risk and will result in the loss of all warranty and liability claims.

#### Trained user

The user has been educated and trained in laboratory work and is able to carry out the work assigned to them, and to recognise and prevent potential hazards independently.

#### Personal protective equipment

Lack of personal protective equipment or unsuitable personal protective equipment increases the risk of impaired health and injury.

- Only use personal protective equipment that is in proper condition.
- Only use personal protective equipment that is adapted to the person (correct size, for example).
- Observe instructions on other protective equipment for specific activities.

## 2.3 Operator's responsibility



*Follow the instructions in this document for proper and safe use of the device.*

*Keep the user manual for future reference.*

### Provide information

- Following the instructions in this document will help:
  - To avoid dangerous situations.
  - To minimise repair costs and downtime.
  - To increase the reliability and service life of the device.
- The operator is responsible for compliance with company regulations, standards and national laws.
- Note and keep the revision of the document separate from the document. If lost, the document can be replaced in the correct revision.
- Keep the user manual available at the place where the device is used.
- Pass the user manual on to the buyer when the device is sold.

### Personnel training

Lack of knowledge when working with the device may result in serious injury or death.

- Instruct personnel on their tasks and the associated risks in accordance with the instruction.

## 2.4 Safety instructions



### **Reporting serious incidents and notifiable incidents**

*In the event of serious incidents or notifiable incidents involving the device or its accessories, these must be reported to the manufacturer and, where applicable, to the competent authority where the user and/or the patient is registered.*



### **DANGER**

**Risk of contamination for the user due to inadequate cleaning or failure to observe the cleaning instructions.**

- Observe cleaning instructions.
- Wear personal protective equipment when cleaning the device.
- Observe laboratory regulations (e.g. TRBAs, the German Protection against Infection Act, hygiene plan) for handling biological agents.



### **DANGER**

**Fire and explosion hazard due to hazardous substances in samples.**

- Observe relevant regulations and directives for handling chemicals and hazardous substances.
- Do not use aggressive chemicals (for example: dangerous, corrosive extraction agents such as chloroform, strong acids).

**WARNING**

**Dangers due to insufficient maintenance or maintenance not carried out on time.**

- Follow maintenance intervals.
- Check the device for visible damage or defects.  
If any visible damage or defects are present, take the device out of service and inform a service technician.

 **WARNING**

**Risk of electric shock due to ingress of water or other liquids.**

- Protect the device against external liquids.
- Do not pour any liquids into the interior of the device.
- Transport using original transport packaging.

 **WARNING**

**Contamination with hazardous substances and substance mixtures!**

Observe the following actions for substances and substance mixtures that are toxic, radioactive and/or contaminated with pathogenic microorganisms:

- As a rule, use only centrifuge tubes with special screw caps for hazardous substances.
- Use sealable centrifuge tubes with a biosafety system for materials of risk groups 3 and 4.
- If no biosafety system is used, the device is not micro-biologically tight in the sense of standard EN / IEC 61010-2-020.
- Contact the manufacturer if necessary.

**WARNING**

**Risk of injury and damage to the device due to a loose rotor.**

- The driver of the rotor shaft must be correctly seated in the groove of the rotor when mounting the rotor.
- Hand-tighten the nut securing the rotor.
- Check that the rotor is firmly seated.
- Follow maintenance intervals.

**CAUTION**

**Risk of injury due to rotating rotor**

Long hair and items of clothing can get caught on the rotor if the rotor is moved manually.

- Tie long hair back.
- Do not allow garments to hang in the centrifuging chamber.



**NOTICE**

**Damage to the device electronics due to incorrect voltage or frequency at the device circuit breaker.**

- Operate the device with the correct mains voltage and mains frequency.  
The value can be found in the technical data and on the rating plate.

**NOTICE**

**Damage to the device and samples due to premature program termination.**

Premature program termination is caused by power failure, switching off during the program or pulling out the mains plug.

- Do not switch off the device while the program is running.
- Do not trigger the emergency release on the device while the program is running.
- Do not pull out the mains plug while the program is running.

### 3 Device overview

#### 3.1 Technical data

Manufacturer	Andreas Hettich GmbH & Co. KG, D-78532 Tuttlingen	
Model	UNIVERSAL 320	
Type	1401	1401-01
Mains voltage ( $\pm 10\%$ )	200-240 V 1~	100-127 V 1~
Mains frequency	50-60 Hz	50-60 Hz
power consumption	400 VA	400 VA
Power consumption	2.0 A	4.0 A
max. capacity	4 x 200 ml	
max. permissible density	1.2 kg/dm <sup>3</sup>	
max. speed (RPM)	16000	
max. acceleration (RCF)	24900	
max. kinetic energy	9800 Nm	
Obligation to perform checks (DGUV Rules 100-500) (valid only in Germany)	No	

<b>Ambient conditions (EN / IEC 61010-1):</b>			
Installation site	indoors only		
Altitude	up to 2000 m above sea level		
Ambient temperature	2 °C to 35 °C		
Humidity	maximum relative humidity 80% for temperatures up to 31 °C, decreasing linearly to 50% relative humidity at 40 °C.		
Overvoltage category (IEC 60364-4-443)	II		
Pollution level	2		
Device protection class	I not suitable for use in potentially explosive atmospheres.		
<b>EMC:</b>			
Emitted EM interference, EM interference immunity	EN / IEC 61326-1 Class B	FCC Class B	
Noise level (rotor-dependent)	≤68 dB(A)		
<b>Dimensions:</b>			
Width	401 mm		
Depth	529 mm		
Altitude	346 mm		
Weight	approx. 31 kg		
Manufacturer	Andreas Hettich GmbH & Co. KG, D-78532 Tuttlingen		
Model	UNIVERSAL 320 R		
Type	1406	1406-01	
Mains voltage (±10%)	200-240 V 1~	240 V 1~	115-127 V 1~
Mains frequency	50 Hz	60 Hz	60 Hz
power consumption	800 VA		950 VA
Power consumption	4.0 A		8.0 A
Refrigerant	R452A		
max. capacity	4 x 200 ml		
max. permissible density	1.2 kg/dm <sup>3</sup>		

max. speed (RPM)	16000	
max. acceleration (RCF)	24900	
max. kinetic energy	9800 Nm	
Obligation to perform checks (DGUV Rules 100-500) (valid only in Germany)	No	
<b>Ambient conditions (EN / IEC 61010-1):</b>		
Installation site	indoors only	
Altitude	up to 2000 m above sea level	
Ambient temperature	5 °C to 35 °C	
Humidity	maximum relative humidity 80% for temperatures up to 31 °C, decreasing linearly to 50% relative humidity at 40 °C.	
Overvoltage category (IEC 60364-4-443)	II	
Pollution level	2	
Device protection class	I not suitable for use in potentially explosive atmospheres.	
<b>EMC:</b>		
Emitted EM interference, EM interference immunity	EN / IEC 61326-1 Class B	FCC Class B
Noise level (rotor-dependent)	≤64 dB(A)	
<b>Dimensions:</b>		
Width	407 mm	
Depth	698 mm	
Altitude	346 mm	
Weight	approx. 52 kg	

Rating plate

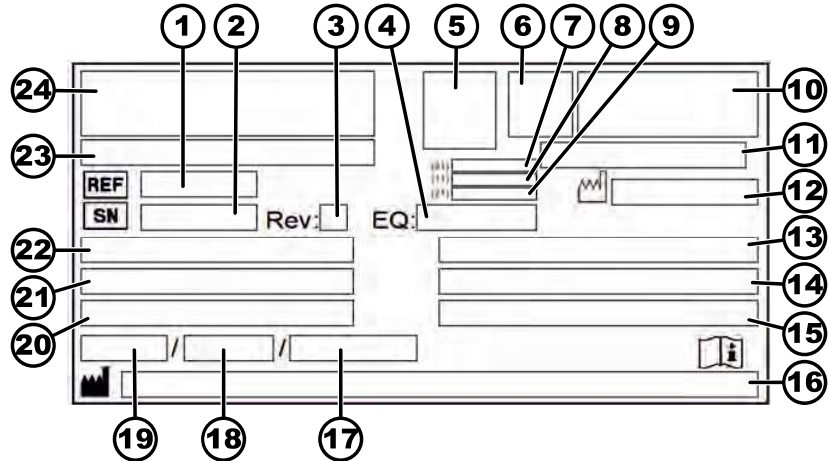

Fig. 1: Rating plate

- 1 Item number
- 2 Serial number
- 3 Revision
- 4 Equipment number
- 5 Data matrix code
- 6 any labelling indicating whether medical device or in vitro diagnostic medical device
- 7 Global Trade Item Number (GTIN)
- 8 Date of manufacture
- 9 Serial number
- 10 any EAC mark, CE mark
- 11 Country of manufacture
- 12 Date of manufacture
- 13 Mains frequency
- 14 Maximum kinetic energy
- 15 Maximum permissible density
- 16 Manufacturer's address
- 17 any Coolant circuit pressure
- 18 any Coolant capacity
- 19 any Coolant type
- 20 Revs per minute
- 21 Performance values
- 22 Mains voltage
- 23 any Device designation
- 24 Manufacturer's logo

### 3.2 European registration

**Device conformity**

Device conformity according to EU directives.



**Single Registration Number**

SRN: DE-MF-000010680

**Basic-UDI-DI**

Basic-UDI-DI	Device assignment
040506740100139R	UNIVERSAL 320 / 320 R (in vitro diagnostic medical device)

### 3.3 Important labels on the packaging



**TOP**  
This is the correct upright position of the shipping container for transport and/or storage.



**FRAGILE GOODS**  
The contents of the shipping container are fragile, so it must be handled with care.



**PROTECT FROM MOISTURE**  
The shipping container must not be exposed to rain and kept in a dry environment.



**TEMPERATURE LIMITATION**  
The shipping container must be stored, transported and handled within the indicated temperature range (-20 °C to +60 °C).



**HUMIDITY LIMITATION**  
The shipping container must be stored, transported and handled within the indicated humidity range (10% to 80%).

nicht kondensierend  
non-condensing  
sans condensation



**STACK LIMITATION BASED ON QUANTITY**  
Maximum number of identical packages that may be stacked on the lowest package, "n" standing for the number of packages allowed. The lowest package is not included in "n".

### 3.4 Important labels on the device



*The signs on the device must not be removed or covered, or have anything pasted over them.*



Attention, general danger area.  
Ensure you read the instructions for commissioning and operation and observe the safety instructions before using the device.



Biohazard warning.



Direction of rotation of the rotor.  
The orientation of the arrow indicates the rotor's direction of rotation.



Symbol for the separate collection of electrical and electronic equipment, in accordance with Directive 2012/19/EU (WEEE).  
Use in European Union countries, Norway and Switzerland.

### 3.5 Operating and indicator elements

#### 3.5.1 Control

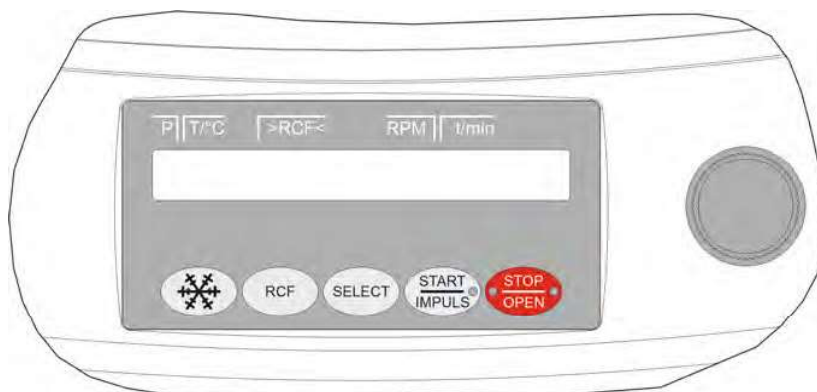

Fig. 2: Control (device with cooling)

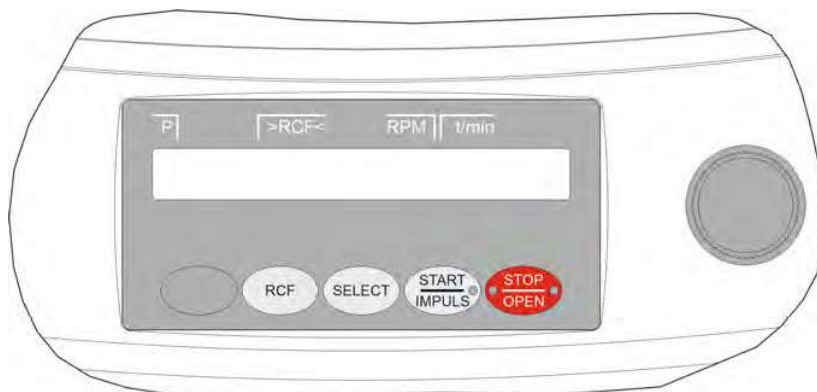

Fig. 3: Control (device without cooling)

### 3.5.2 Indicator elements



Fig. 4: [START/IMPULS] button

- The button lights up during the centrifugation run for as long as the rotor is not yet at a standstill.



Fig. 5: [STOP/OPEN] button

- The right side of the button lights up when the centrifuge is in ramp-down. The rotor has not yet stopped.
- The left side of the button lights up when the rotor is stationary.
- The light on the left side of the button goes out when the lid is unlocked.

### 3.5.3 Controls



Fig. 6: [Rotary knob]

- Setting the individual parameters.  
Turning anticlockwise decreases the value.  
Turning clockwise increases the value.



Fig. 7: [Mains switch]

- Switch the device on and off.



Fig. 8: [Cooling] button

- Start the centrifugation run to pre-cool the rotor (only for centrifuges with cooling).
- The precooling speed is adjustable. The default value is 10,000 RPM.



Fig. 9: [RCF] button

- Toggle between RCF indicator and RPM indicator.
- Relative centrifugal force, RCF.  
The RCF is displayed in brackets >{.
- Speed, RPM.

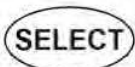

Fig. 10: [SELECT] button

- Selecting the individual parameters.
- Scroll forward in the menus.



Fig. 11: [START/IMPULSE] button

- Start centrifugation run.
- Short-time centrifugation. The centrifugation run takes place as long as the button is being pressed.
- Save entries and changes.



Fig. 12: [STOP/OPEN] button

- End the centrifugation run.  
The rotor coasts to a stop with the preselected ramp-down parameter.
- Pressing the button twice triggers the quick stop function.
- Unlock the lid.
- Exit parameter input and the menus.

## 3.6 Original spare parts

Use only original spare parts from the manufacturer and approved accessories.

### 3.7 Scope of delivery

The following accessories are supplied with the centrifuge:

- 1 hex key (SW5 x 100)
- 1 grease for the trunnions
  
- 1 power cable
- 1 user manual
- 1 instruction sheet, transport lock

Rotors and the corresponding accessories are supplied depending on the order.

### 3.8 Returns

An original Return Material Authorisation (RMA) form from the manufacturer must always be requested for a return. Secure and reliable acceptance and booking in of the goods with the manufacturer is not possible without an original RMA form from the manufacturer. The Return Material Authorisation (RMA) form contains a Declaration of No Objection (UBE), which must be completed in full and enclosed with the return.

If the device and/or accessories are returned to the manufacturer, the complete return shipment must be cleaned and decontaminated by the sender. If returns are not cleaned and/or decontaminated or are insufficiently cleaned and/or decontaminated, this will be performed by the manufacturer and charged to the sender.

The original transport locks must be attached for return shipment, see → Chapter 4 'Transport and storage' on page 16. The device must be shipped in its original packaging.

## 4 Transport and storage

### 4.1 Transport and storage conditions

#### Transport conditions



#### NOTICE

**Damage to the device due to failure to use the transport locks.**

- Secure the transport locks before transporting the device.



#### NOTICE

**Damage to the device due to condensation.**

There is a risk of condensation forming on electrical components when component surfaces are cold and the surrounding air is warmer. The condensation that forms may cause a short circuit and/or destroy electronics.

- Warm the device up for at least 3 hours in a warm room before connecting it to the mains.  
or
- Warm up for 30 minutes in a cold room.



- Before transporting, fasten the transport lock and disconnect the device from the mains socket.
- The transport temperature must be between -20 °C and +60 °C.
- Humidity must not be condensing. Humidity must be between 10% and 80%.
- Be aware of the weight of the device.
- When transporting using a transport aid (e.g., a pallet truck), the transport aid must be able to carry at least 1.6 times the transport weight of the device.
- Secure the device to prevent it tipping over and falling down during transport.
- Never transport the device sideways or upside down.

**Storage conditions**

- The device must be stored in the original packaging.
- Only store the device in dry rooms.
- The storage temperature must be between -20 °C and +60 °C.
- Humidity must not be condensing. Humidity must be between 10% and 80%.

**4.2 Fastening the transport lock**

**Personnel:**

- Trained user

1. ➤ Open the lid.
2. ➤ For UNIVERSAL 320 R:  
Check the bellows (3) underneath the motor cover for correct seating.  
The bellows (3) must be placed over the edge of the motor cover (1) and over the edge of the centrifuging chamber (2).
3. ➤ Close the lid.

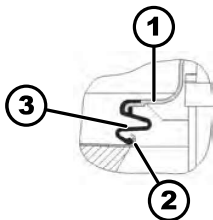

- 1 Motor cover
- 2 Edge of the centrifuging chamber
- 3 Bellows

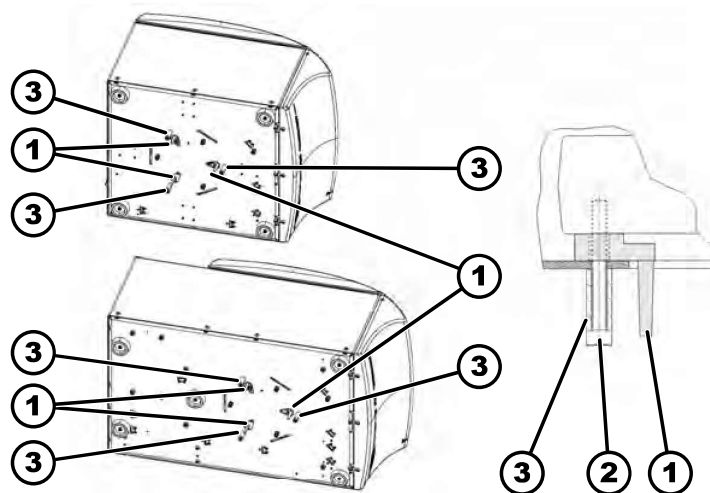



Fig. 13: Transport lock

- 1 Transport lock
  - 2 Screw
  - 3 Spacer sleeve
4. ➤ Lay the device down on its right-hand side.

5.  Insert 3 transport locks (1).
6.  Screw in 3 screws (2) with spacer sleeves (3).

## 5 Commissioning

### 5.1 Unpacking the centrifuge



#### CAUTION

Danger of crushing due to parts falling out of the transport packaging.

- Keep the device balanced during the unpacking process.
- Only open the packaging at the points provided for this purpose.



#### CAUTION

Risk of injury from lifting heavy loads.

- Provide an adequate number of helpers.
- Note the weight. See  *Chapter 3.1 'Technical data' on page 9.*









#### NOTICE

Damage to the device due to improper lifting.

- Do not lift the centrifuge by the control panel or the control panel holder.

#### Personnel:

- Trained user

1.  Unscrew the screws on the lid of the wooden packaging and store them.
2.  Remove the lid.
3.  Unscrew the screws on the side panels of the wooden packaging and store them.
4.  Remove the side panels.
5.  Remove padding and strips.
6.  Remove the device and accessories by lifting them up out of the box.
7.  Place the device on a stable and level surface.

### 5.2 Removing the transport lock

#### Personnel:

- Trained user

The lid is closed.

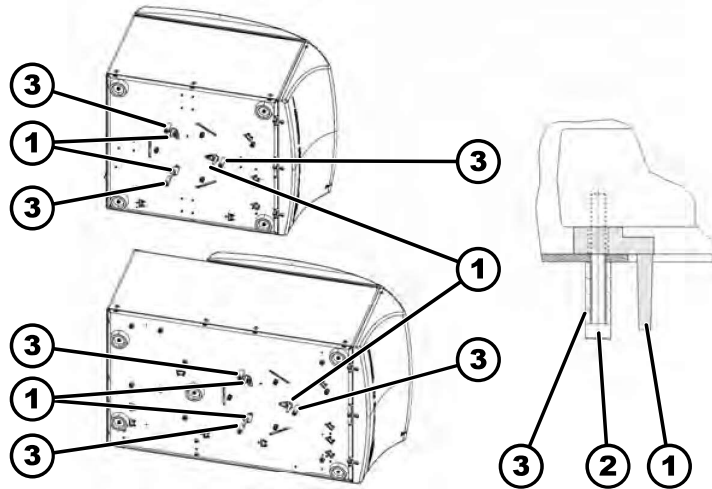
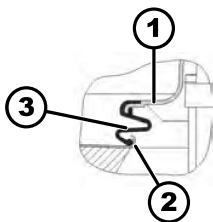

Fig. 14: Transport lock

- 1 Transport lock
- 2 Screw
- 3 Spacer sleeve

1. Lay the device down on its right-hand side.
2. Unscrew 3 screws (2) with 3 spacer sleeves (3).
3. Remove 3 transport locks (1).
4. Keep the screws, spacer sleeves and transport locks in a safe place.
5. Place the device upright.
6. Open the lid.
7. For UNIVERSAL 320 R:  
Check the bellows (3) underneath the motor cover for correct seating.

The bellows (3) must be placed over the edge of the motor cover (1) and over the edge of the centrifuging chamber (2).



- 1 Motor cover
- 2 Edge of the centrifuging chamber
- 3 Bellows

### 5.3 Setting up and connecting the centrifuge

#### Setting up the centrifuge



#### WARNING

Risk of injury due to failing to maintain a sufficient distance to the centrifuge.

- As per EN / IEC 61010-2-020, no persons, hazardous materials or objects may be present within a **safety zone of 300 mm** around the centrifuge during a centrifugation run.
- A distance of **300 mm** from the ventilation slots and ventilation openings of the centrifuge must be maintained.

**CAUTION**

Risk of crushing and damage to the device due to it falling down because of vibration-induced position alterations.

- Place the device on a stable and level surface.
- Select the installation surface dependent on the weight of the device.

**NOTICE**

Damage to the samples and the device if the ambient temperature exceeds or falls below the respective maximum/minimum permissible ambient temperature.

- Comply with the maximum and minimum permissible ambient temperatures for installation of the device.
- Do not place the device next to a heat source.
- Do not expose the device to direct sunlight.
- Do not expose the device to frost.

**Personnel:**

- Trained user

1. ➤ Place the device on a stable and level surface.
2. ➤ Maintain a distance of 300 mm around the device.
3. ➤ Comply with the ambient conditions in the technical data (→ *Chapter 3.1 'Technical data' on page 9*).

**Connecting the centrifuge****NOTICE**

**Damage to the device by unauthorised personnel**

- Tampering with and modifications to devices by unauthorised persons are at the operating organisation's own risk and will result in the loss of all warranty and liability claims.

**NOTICE**

**Damage to the device due to condensation.**

There is a risk of condensation forming on electrical components when component surfaces are cold and the surrounding air is warmer. The condensation that forms may cause a short circuit and/or destroy electronics.

- Warm the device up for at least 3 hours in a warm room before connecting it to the mains.  
or
- Warm up for 30 minutes in a cold room.

**Personnel:**

- Trained user

1. ➤ A type B residual current circuit breaker must be used if the device is additionally protected with a residual current circuit breaker in the building installation.

When using a different type, the residual current circuit breaker may either not switch off the unit if there is a fault on the unit, or it may switch off the unit even though there is no fault on the unit.

2. → Check whether the mains voltage matches the specification on the rating plate.
3. → Connect the device to a standard mains socket using the mains cable.

## 5.4 Switching the centrifuge on and off.

### Switching the centrifuge on

#### Personnel:

- Trained user

→ Set the mains switch to */I/*.

- ➔ The buttons flash, depending on the centrifuge type.

The following indicators appear one after the other, depending on the centrifuge type:

- the centrifuge model and program version
- When the lid is closed: 'OPEN OEFFNEN' indicator
- When the lid is open: The last centrifugation data used.

### Switching off the centrifuge

The rotor is stationary.

→ Set the mains switch to */O/*.

## 6 Operation

### 6.1 Opening and closing the lid

#### Opening the lid

#### Personnel:

- Trained user

The centrifuge is switched on

The rotor is stationary.

→ Press the *[STOP/OPEN]* button.

- ➔ The lid unlocks by means of a motor.

The light on the left side of the *[STOP/OPEN]* button goes out.

#### Closing the lid



#### CAUTION

##### Crushing hazard when closing the lid.

Danger of fingers getting crushed when the closing motor pulls the lid against the seal.

- No parts of the operator's body should be in the hazard zone of the lid when closing the lid.
- To close the lid, press on the lid from above.



#### NOTICE

##### Damage to the device caused by the lid slamming.

- Close the lid slowly.
- Do not slam the lid.



When the left side of the [STOP/OPEN] button flashes, press the [STOP/OPEN] button so that the motorised lid lock assumes the home position (open).

**Personnel:**

- Trained user

→ Close the lid and press the front edge of the lid down gently.

- ➔ The lid locks using a motor.

The left side of the [STOP/OPEN] button lights up.

## 6.2 Removing and installing the rotor

### Removing the rotor with a clamping nut

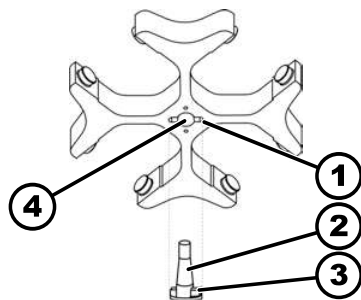

Fig. 15: Rotor installation and removal

- 1 Groove
- 2 Motor shaft
- 3 Driver
- 4 Hole

**Personnel:**

- Trained user

1. → Open the lid.

2. → Loosen the rotor clamping nut using the supplied spanner.

- ➔ After passing the working point for lifting the rotor, the rotor detaches from the cone of the motor shaft (2).

3. → Turn the clamping nut until the rotor can be lifted off the motor shaft.

4. → Remove the rotor.

### Installing the rotor with a clamping nut

**Personnel:**

- Trained user

The lid is open.

1. → Clean the motor shaft (2) and rotor hole (4).

2. → Lightly grease the motor shaft (2), see ➔ Chapter 8.2 'Instructions for cleaning and disinfection' on page 36.

3. → Place the rotor vertically on the motor shaft (2).

- ➔ The driver (3) of the motor shaft must be in the groove (1) of the rotor. The orientation of the groove is marked on the rotor.

4. → Hand-tighten the rotor clamping nut using the supplied spanner.

5. → Check that the rotor is firmly seated.

### Removing the rotor without a clamping nut

#### Removing the rotor

**Personnel:**

- Trained user

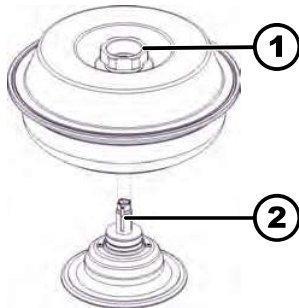

→ Hold the rotor by the rotary handle (1) of the lid and lift it off the hub (2).

Fig. 16: Rotor installation and removal

- 1 Rotary handle
- 2 Hub

### Removing the hub

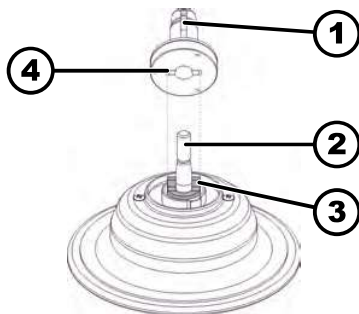

1. → Open the lid.
2. → Unscrew the clamping nut.
  - ➔ After passing the working point for lifting the rotor, the hub (1) detaches from the cone of the motor (2).
3. → Remove the hub.

Fig. 17: Hub installation and removal

- 1 Hub
- 2 Motor shaft
- 3 Driver
- 4 Groove

### Installing the rotor without a clamping nut

#### Installing the hub

#### Personnel:

- Trained user

1. → Open the lid.
  2. → Clean the motor shaft (2) and rotor hole.
  3. → Lightly grease the motor shaft (2), see ➔ Chapter 8.2 'Instructions for cleaning and disinfection' on page 36.
  4. → Place the hub (1) vertically on the motor shaft (2).  
The driver (3) of the motor shaft must be in the groove (4) of the hub.  
Check that the hub is firmly seated.
  5. → Hand-tighten the clamping nut of the hub using the supplied hex key.
  6. → Check that the hub is firmly seated.
- #### Installing the rotor
1. → Clean the hub (2).
  2. → Lift the rotor by the rotary handle and place it vertically on the hub (2).
  3. → Push the rotor down as far as it will go.

## 6.3 Inserting and removing buckets

### Inserting buckets



#### NOTICE

Damage to the device due to imbalances caused by incorrect loading of the rotor.

- Load all swing-out rotor locations with the same buckets.



*Buckets marked with the number of the rotor location may only be used there.*

*Buckets marked with a set number may only be used together.*

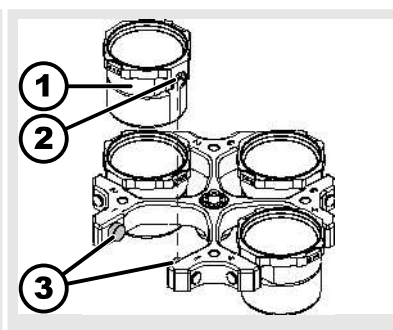
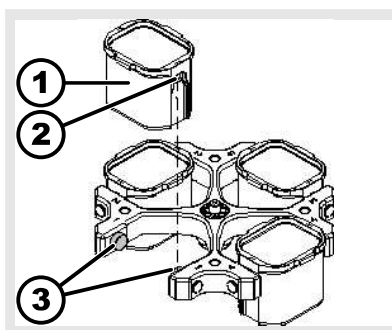

1. Check that the rotor is firmly seated.
2. Grease the trunnions (3).
3. Insert the bucket (1) into the rotor from above. The trunnions (3) must be in the grooves (2).
4. Push the bucket (1) down as far as it will go.

### Removing the bucket

- Pull the bucket (1) vertically upwards out of the rotor.

## 6.4 Inserting and removing adapters

### Inserting

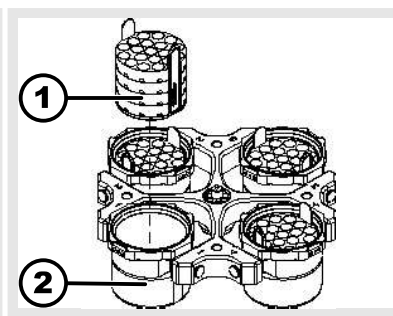
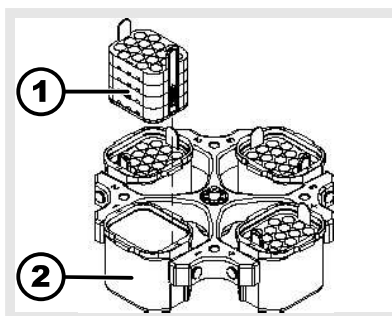

### the adapter

- Insert the adapter (1) vertically into the bucket (2) from above.

### removing

- Remove the adapter (1) vertically upwards out of the bucket (2).



**Adapter with positioning pin**

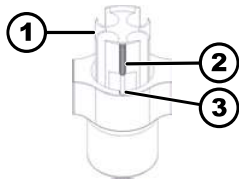

Fig. 18: Adapter with positioning pin

- 1 Inserting
- 2 Positioning pin
- 3 Inserting

**the groove**

- ➔ Insert the adapter (1) into the bucket
- The positioning pin (2) must be in the groove (3) of the bucket.

**removing**

- ➔ Remove the adapter (1) vertically upwards out of the bucket.

## 6.5 Loading

### Filling centrifuge tubes



**WARNING**

**Risk of injury from contaminated sample material.**

Contaminated sample material escapes from the sample tube during centrifugation.

- Use centrifuge tubes with special screw caps for hazardous substances.
- For risk group 3 and 4 materials, use a biosafety system in addition to the sealable centrifuge tubes (see WHO's 'Laboratory Biosafety Manual').



**NOTICE**

**Damage to the device due to highly corrosive substances.**

Highly corrosive substances may impair the mechanical strength of rotors, buckets and accessories.

- Do not centrifuge highly corrosive substances.



*Standard glass centrifuge tubes can be loaded up to RCF 4000 (DIN 58970 part 2).*

**Personnel:**

- Trained user

- ➔ Fill centrifuge tubes outside the centrifuge.  
The maximum capacity of the centrifuge tubes specified by the manufacturer must not be exceeded.

With angle rotors, the centrifuge tubes must only be filled to the extent that no liquid can be ejected from the tubes during the centrifugation run.

It must be ensured that there is a uniform fill level in the tubes in order to keep the weight differences in the centrifuge tubes as low as possible.

**Loading swing-out rotors**

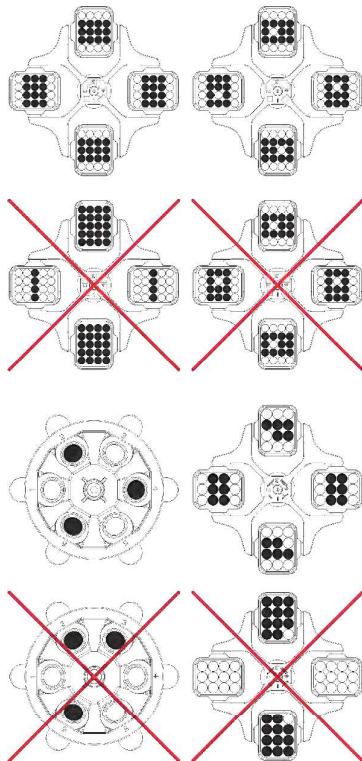

**Loading the angle rotors**

**Personnel:**

- Trained user

1. ➔ Check that the rotor is firmly seated.
2. ➔ The centrifuge tubes must be distributed symmetrically across all rotor locations.

The weight of the permissible filling capacity is indicated on each rotor. The weight must not be exceeded.

No liquid must be allowed to enter the buckets and the centrifuging chamber when loading the buckets and swinging them out during the centrifugation run.

For containers with rubber inserts, there must always be the same number of rubber inserts under the centrifuge tubes.

All rotor locations must be filled with the same buckets. Certain buckets are marked with the number of the rotor location. The buckets must only be inserted in the corresponding rotor location.

Buckets marked with a set number (for example S001/4) must only be used in the set.

**Personnel:**

- Trained user

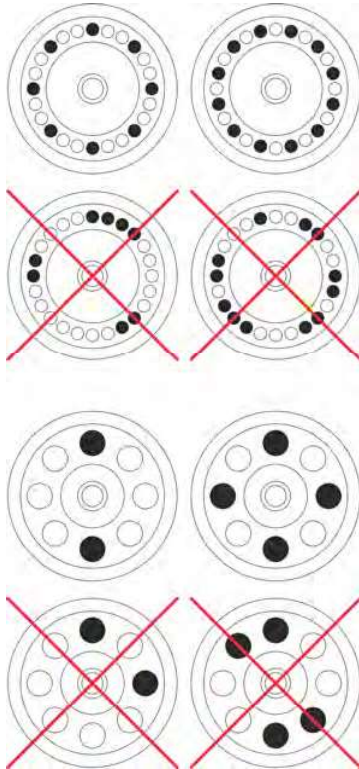

1. → Check that the rotor is firmly seated.
2. → The centrifuge tubes must be distributed evenly over all locations on the rotor.

No liquid must be allowed to enter the rotor and the centrifuging chamber when loading the rotor.

With rotors, the centrifuge tubes must only be filled to the extent that no liquid can be ejected from the tubes during the centrifugation run.

The weight of the permissible filling capacity is indicated on each rotor. The weight must not be exceeded.

## 6.6 Opening and closing the biosafety system

### 6.6.1 Explanation

The user must take appropriate actions when centrifuging hazardous substances or mixtures of substances that are toxic, radioactive or contaminated with pathogenic microorganisms.

Centrifuge tubes with special screw caps for hazardous substances must always be used.

For materials of risk group 3 and 4, a biosafety system must be used in addition to the sealable centrifuge tubes (see the World Health Organisation's "Laboratory Biosafety Manual").

In a biosafety system, a bioseal (sealing ring) prevents droplets and aerosols from escaping.

If the bucket of a biosafety system is used without the lid, the sealing ring must be removed from the bucket to prevent damage to the sealing ring during the centrifugation run.

Damaged biosafety systems are no longer microbiologically tight.

If no biosafety system is used, a centrifuge is not microbiologically tight in the sense of the EN / IEC 61010-2-020 standard.

#### Storage of biosafety systems

Biosafety systems must only be stored with the lid open to avoid damage to the sealing rings during storage.

### 6.6.2 Lid with screw cap and hole

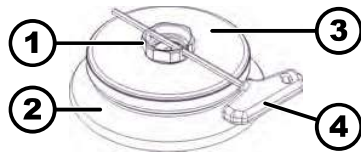

Fig. 19: Biosafety system

- 1 Rotary handle
- 2 Rotor
- 3 Lid
- 4 Key

#### Closing

1. Place the lid (3) centrally on the rotor (2).
2. Insert the supplied key (4) into the hole in the rotary handle (1).
3. Turn the lid (3) at the key (4) clockwise until it is tightly closed.

#### Opening

1. Insert the supplied key (4) into the hole in the rotary handle (1).
2. Turn the lid (3) at the key (4) anticlockwise until it is open.
3. Remove the lid (3) from the rotor (2).

### 6.6.3 Lid with bracket and spring-type lock

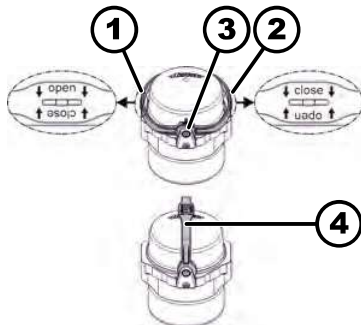

Fig. 20: Biosafety system

- 1 Bracket position "open"
- 2 Bracket opening operations
- 3 Bracket position "close"
- 4 Bracket carrying position

#### Closing

1. Swivel the bracket to the "open" position (1).  
The arrows of the labelling must point downwards so that the word "open" is legible.
2. Place the lid centrally on the bucket.  
The two pins of the lid must be in the two openings of the bracket (2).
3. Swivel the bracket to the "close" position (3).  
The arrows of the labelling must point downwards so that the word "close" is legible.  
The bracket must rest on the bucket so that the bucket can swing out during the centrifugation run.

4. ➤ For transport or when inserting and removing the bucket, swing the bucket into the carrying position (4) and hold the bucket by the bracket.
  - ➡ The tightness of the biosafety system is also guaranteed in the carrying position.
 

Do not rock the biosafety system back and forth during transport, otherwise leak-tightness is no longer ensured.

**Opening**

1. ➤ Swivel the bracket to the "open" position (1).  
The arrows of the labelling must point downwards so that the word "open" is legible.
2. ➤ Remove the lid from the bucket.

**6.6.4 Lid with screw cap**

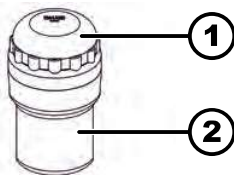

Fig. 21: Biosafety system

- 1 Lid
- 2 Bucket

**Closing**

1. ➤ Place the lid (1) centrally on the bucket (2).
2. ➤ Turn the lid (1) clockwise until it is tightly closed.

**Opening**

1. ➤ Turn the lid (1) anticlockwise until it is open.
2. ➤ Remove the lid (1) from the bucket (2).

**6.7 Centrifugation**

**6.7.1 Centrifugation in continuous operation**

**Personnel:**

- Trained user

1. ➤ Set minutes and seconds at '∞' or retrieve a continuously running program.
2. ➤ Press the [START/IMPULS] button.
  - ➡ The centrifugation run is started.
 

The [START/IMPULSE] button lights up during the centrifugation run.

The timing starts at '00:00'.

The rotor speed or the RCF value, the temperature in the centrifuging chamber (only for centrifuges with cooling) and the elapsed time are displayed during the centrifugation run.
3. ➤ Press the [STOP/OPEN] button to cancel the centrifugation run.
 

Ramp-down takes place with the set brake level. The brake level is displayed.



An audible signal sounds when the rotor comes to a standstill.

'OPEN' 'OEFFNEN' is displayed.

## 6.7.2 Centrifugation with time preselection

### Personnel:



- Trained user

1.  Set centrifugation parameters or retrieve a program.
2.  Press the *[START/IMPULS]* button.
  - ➔ The centrifugation run is started.  
The *[START]* button lights up during the centrifugation run.  
The rotor speed or the RCF value, the temperature in the centrifuging chamber (only for centrifuges with cooling) and the remaining time are displayed during the centrifugation run.
3.  Ramp-down takes place with the selected brake level after the time has elapsed or if the centrifugation run is cancelled.
  - ➔ The brake level is displayed.  
An audible signal sounds when the rotor comes to a standstill.  
'OPEN' 'OEFFNEN' is displayed.  
The right side of the *[STOP/OPEN]* button lights up when the centrifuge is in ramp-down.  
The left side of the *[STOP/OPEN]* button lights up when the rotor is at a standstill.  
The light on the *[START/IMPULS]* button and the right side of the *[STOP/OPEN]* button go out.

## 6.7.3 Short-time centrifugation

### Personnel:

- Trained user

1.  Press and hold the *[START/IMPULS]* button.
  - ➔ The *[START/IMPULS]* button lights up during the centrifugation run.  
Timing starts at 00:00.  
The rotor speed or the RCF value, the temperature in the centrifuging chamber (only for centrifuges with cooling) and the elapsed time are displayed during the centrifugation run.
2.  Release the *[START/IMPULSE]* button to end the centrifugation run.
  - ➔ Ramp-down takes place with the set brake level. The brake level is displayed.  
An audible signal sounds when the rotor comes to a standstill.  
'OPEN' 'OEFFNEN' is displayed.

## 6.8 Quick stop function

### Personnel:

- Trained user

-  Press the *[STOP/OPEN]* button twice.
  - ➔ Ramp-down with brake level "9" (shortest ramp-down time) is displayed and executed.

## 7 Software operation

### 7.1 Centrifugation parameters

#### 7.1.1 Relative centrifugal force, RCF

The relative centrifugal force RCF is dependent on the speed and the centrifuging radius.

The relative centrifugal force RCF is stated as a multiple of the acceleration due to gravity (g).

The relative centrifugal force RCF is a dimensionless numerical value and is used to compare the separation and sedimentation performance.

$$\text{RCF} = \left( \frac{\text{RPM}}{1000} \right)^2 * r * 1,118$$

$$\text{RPM} = \sqrt{\frac{\text{RCF}}{r * 1,118}} * 1000$$

RCF = Relative Centrifugal Force

RPM = speed

r = centrifuging radius in mm = distance from the centre of the axis of rotation to the bottom of the centrifuge tube.

#### 7.1.2 Centrifugation of substances or mixtures of substances with a density higher than 1.2 kg/dm<sup>3</sup>

The density of the substances or mixtures of substances must not exceed 1.2 kg/dm<sup>3</sup> during centrifugation at maximum speed. The speed must be reduced for substances or substance mixtures with a higher density. The permissible speed can be calculated using the following formula:

$$\text{Reduced speed } (n_{red}) = \sqrt{\frac{1,2}{\text{Greater density [kg/dm}^3]}} * \text{maximum speed [RPM]}$$

For example: Maximum speed 4000 RPM, density 1.6 kg/dm<sup>3</sup>

$$n_{red} = \sqrt{\frac{1,2(\text{kg/dm}^3)}{1,6(\text{kg/dm}^3)}} * 4000 \text{ RPM} = 3464 \text{ RPM}$$

If, in exceptional cases, the maximum load indicated on the bucket is exceeded, the speed must also be reduced. The permissible speed can be calculated using the following formula:

$$\text{Reduced speed } (n_{red}) = \sqrt{\frac{\text{maximum load [g]}}{\text{actual load [g]}}} * \text{maximum speed [RPM]}$$

For example: Maximum speed 4000 RPM, maximum load 300 g, actual load 350 g

$$n_{red} = \sqrt{\frac{300 \text{ g}}{350 \text{ g}}} * 4000 \text{ RPM} = 3703 \text{ RPM}$$





Please contact the manufacturer if you are not sure.

## 7.2 Programming





### 7.2.1 Write protection for programs

The programs can be protected to prevent unintentional changes.







When the rotor is at a standstill, write protection can be enabled or disabled as follows:

1.  Press and hold the *[SELECT]* button.
  - 'SOUND/BELL' is displayed after 8 seconds.
2.  Press the *[SELECT]* button.
  - 'LOCK' is displayed.
3.  Use *[Rotary knob]* to set 'OFF' or 'ON'.
  - OFF = The programs are not write-protected
  - ON = The programs are write-protected
4.  Press the *[START/IMPULS]* button.
  - The setting is stored.
  - If ON is set: '\*\*\* lock \*\*\*' is displayed briefly.
  - If OFF is set: '\*\*\* ok \*\*\*' is displayed briefly.

### 7.2.2 Opening or loading programs

1.  Use the *[SELECT]* button to select the 'PROG RCL' parameter.
2.  Use the *[Rotary knob]* to set the desired program location.
3.  Press the *[START/IMPULS]* button.
  - '\*\*\* ok \*\*\*' is displayed briefly.
  - The centrifugation data of the desired program location is displayed
4.  To check the parameters: Press the *[SELECT]* button several times.
5.  To exit the parameter indicator: Press the *[OPEN/STOP]* button or do not press any button for 8 seconds.

### 7.2.3 Entering or changing programs

1.  Retrieve program.
2.  If required: Press the *[RCF]* button to toggle between RPM and RCF indicator ('>' '<').
3.  If required: Press the *[SELECT]* button to select the desired parameter and set it with the *[Rotary knob]*.
  - The parameters t/min and t/sec must be set to 0 with the *[Rotary knob]* to set continuous operation. Continuous operation is shown in the indicator with '∞'.
4.  Use the *[SELECT]* button to select the 'PROG STO' parameter.
5.  Use the *[Rotary knob]* to set the desired program location.
6.  Press the *[START/IMPULS]* button.
  - Settings are stored in the desired program location.
  - '\*\*\* ok \*\*\*' is displayed briefly.
  - The settings are always stored in program location # if the *[START/IMPULS]* button is pressed without the 'PROG STO' parameter being selected.



## 7.3 Rotor detection

- Rotor detection is performed after starting a centrifugation run.
- If the rotor has been changed, the centrifugation run is cancelled after rotor detection. The rotor code (red) is displayed.
- If the maximum speed of the rotor used is less than the set speed, the speed is limited to the maximum rotor speed.

## 7.4 Cooling (for centrifuges with cooling)





### 7.4.1 Instructions, cooling

The temperature setpoint can be adjusted from -20 °C to +40 °C.  
The lowest achievable temperature is rotor dependent.

### 7.4.2 Standby cooling

After a centrifugation run, standby cooling is delayed and the display shows 'Lid unlocked'.



The delay time is adjustable from 1 to 5 minutes, in 1-minute increments. It is preset to 1 minute.

- The rotor is stationary.
  - The lid is open
1.  Press and hold the [Cooling] button.
    - ➔ 't/min = X' is displayed after 8 seconds.
  2.  Use the [Rotary knob] to set the delay time.
  3.  Press the [START/IMPULS] button.
    - ➔ The setting is stored.
    - \*\*\*\* ok \*\*\*\* is displayed briefly.
  4.  Press the [STOP/OPEN] button twice or wait 8 seconds to exit the menu.

### 7.4.3 Precooling the rotor



#### Starting

The rotor is stationary.

1.  Press the [Cooling] button.
2.  Press the [STOP/OPEN] button.
  - ➔ Precooling of the rotor is terminated.
  - Ramp-down takes place with the selected brake level.
  - The brake level is displayed.

#### Set

The precooling speed is adjustable from 500 RPM up to the maximum rotor speed in increments of 10 RPM. It is preset to 10000 RPM.

- The rotor is stationary.
  - The lid is open.
1.  Press and hold the [Cooling] button.
    - ➔ 't/min = X' is displayed after 8 seconds.
  2.  Press the [Cooling] button.
    - ➔ Precooling speed 'RPM = XXXX' is displayed.
  3.  Use the [Rotary knob] to set the precooling speed.

4. ▶ Press the *[START/IMPULS]* button.
  - The setting is stored.
  - \*\*\*\* ok \*\*\*\** is displayed briefly.
5. ▶ Press the *[STOP/OPEN]* button twice or wait 8 seconds to exit the menu.

## 7.5 Machine Menu

### 7.5.1 Querying system information

#### Parameter query

The rotor is stationary.

1. ▶ Press and hold the *[SELECT]* button for 8 seconds.
  - *'SOUND/BELL'* is displayed.
2. ▶ Press the *[SELECT]* button repeatedly until *'FU/CCI – S.'* is displayed.  
Program version for the frequency converter
3. ▶ Press the *[SELECT]* button repeatedly until *'HOURS'* is displayed.  
Internal operating hours (the time during which the centrifuge was switched on)
4. ▶ Turn to the right with the *[Rotary knob]*.
  - *'STARTS'* is displayed.
  - Number of centrifugation runs
5. ▶ Turn to the right with the *[Rotary knob]*.
  - *'ROTORCHG1'* is displayed.
  - Internal operating hour of the last rotor change
6. ▶ Turn to the right with the *[Rotary knob]*.
  - *'ROTORCHG2'* is displayed.
  - Internal operating hour of the penultimate rotor change
7. ▶ Turn to the right with the *[Rotary knob]*.
  - *'OPhoursCHG'* is displayed.
  - Internal operating hour of the last operating hours change
8. ▶ Turn to the right with the *[Rotary knob]*.
  - *'IMBALCHG'* is displayed.
  - Internal operating hour of the last imbalance cut-off change
9. ▶ Turn to the right with the *[Rotary knob]*.
  - *'OffsetCHG'* is displayed.
  - Internal operating hour of the last offset adjustment
10. ▶ Press the STOP/OPEN button to exit the menu.

### 7.5.2 Querying operating hours

The rotor is stationary.

1. ▶ Press and hold the *[SELECT]* button.
  - *'SOUND/BELL'* is displayed after 8 seconds.
2. ▶ Press the *[SELECT]* button repeatedly until *'CONTROL:.'* is displayed.
  - *'CONTROL:.'* and the operating hours are displayed.
3. ▶ Press the *[STOP/OPEN]* button to exit the menu.

### 7.5.3 Audible signal

#### 7.5.3.1 General

The audible signal sounds:

- after a problem occurs in the 2 s interval.
- after completion of the centrifugation run and rotor standstill in the 30 s interval.

Opening the lid or pressing any button stops the audible signal.

#### 7.5.3.2 Setting an audible signal

1. ➤ Press and hold the *[SELECT]* button.
  - ➔ 'SOUND / BELL ON' or 'SOUND / BELL OFF' is displayed after 8 seconds.
2. ➤ Use *[Rotary knob]* to set 'OFF' or 'ON'.
  - OFF = audible signal disabled
  - ON = audible signal enabled
3. ➤ Press the *[START/IMPULS]* button.
  - ➔ The setting is stored.
  - \*\*\*\* ok \*\*\*\* is displayed briefly.

## 8 Cleaning and care

### 8.1 Overview table

Chap.	Task to execute	if required	daily	weekly	Annually	Page
<b>8</b>	<b>Cleaning and care</b>					35
<b>8.3</b>	<b>Cleaning</b>					36
8.3	Cleaning the device		X			36
8.3	Cleaning biosafety systems			X		37
8.3	Cleaning accessories			X		37
<b>8.4</b>	<b>Disinfection</b>					37
8.4	Disinfecting the device	X				37
8.4	Disinfecting the accessories	X				37
<b>8.5</b>	<b>Maintenance</b>					38
8.5	Greasing the rubber seal of the centrifuging chamber			X		38
8.5	Greasing the rubber seal of the biosafety system			X		38
8.5	Trunnion greasing			X		38

Chap.	Task to execute	if required	daily	weekly	Annually	Page
8.5	Checking the accessories			X		38
8.5	Checking the biosafety system			X		38
8.5	Centrifuging chamber damage inspection				X	38
8.5	Greasing the motor shaft				X	38
8.5	Accessories with a limited service life	X				39
8.5	Replacing centrifuge tubes	X				39

## 8.2 Instructions for cleaning and disinfection



### DANGER

Risk of contamination for the user due to inadequate cleaning or failure to observe the cleaning instructions.

- Observe cleaning instructions.
- Wear personal protective equipment when cleaning the device.
- Observe laboratory regulations (e.g. TRBAs, the German Protection against Infection Act, hygiene plan) for handling biological agents.

- The device and its accessories must not be cleaned in dishwashers.
- Only perform hand cleaning and liquid disinfection.
- The water temperature must not exceed 25 °C.
- To prevent any corrosion due to use of detergents or disinfectants, it is essential to follow the special application instructions provided by the manufacturers of the detergent or disinfectant.

### Disinfectant:

- Surface disinfectant (not disinfectant for hands or instruments)
- Ethanol as the sole active substance.  
Do not use an ethanol-propanol mixture to disinfect the viewing window in the lid of the device.
- Concentration not less than 30%
- pH: 6 – 8
- Non-corrosive

## 8.3 Cleaning

### Cleaning the device

1. ➤ Open the lid.
2. ➤ Switch off the device and disconnect it from the power supply.
3. ➤ Remove accessories.
4. ➤ Clean the centrifuge housing and the centrifuging chamber with soap or a mild detergent and a damp cloth.
5. ➤ Remove any detergent residues with a damp cloth after using detergents.

6. → The surfaces must be dried immediately after cleaning.
7. → Dry the centrifuging chamber with an absorbent cloth if condensation forms.

#### Cleaning biosafety systems

1. → Clean the biosafety system using the detergent and a damp cloth.
2. → Remove any detergent residues with a damp cloth after using detergents.
3. → Dry the accessories immediately after cleaning using a lint-free cloth and oil-free compressed air. Dry all cavities completely using oil-free compressed air.

#### Cleaning accessories

1. → Clean the accessories using the detergent and a damp cloth.
2. → Remove any detergent residues with a damp cloth after using detergents.
3. → Dry the accessories immediately after cleaning using a lint-free cloth and oil-free compressed air. Dry all cavities completely using oil-free compressed air.

## 8.4 Disinfection



*Disinfection must always be preceded by cleaning the components concerned.*

*See → Chapter 8.3 'Cleaning' on page 36*



*Disinfectant concentration and application time according to the manufacturer's instructions.*

#### Disinfecting the device



#### CAUTION

**Risk of injury due to ingress of water or other liquids.**

- Protect the device against external liquids.
- Do not disinfect the device using spray.

1. → Open the lid.
2. → Switch off the device and disconnect it from the power supply.
3. → Remove accessories.
4. → Clean the housing and centrifuging chamber using disinfectant.
5. → Remove any disinfectant residues with a damp cloth after using disinfectants.
6. → The surfaces must be dried immediately after cleaning.

#### Disinfecting the accessories

1. → Disinfect the accessories using the disinfectant.
2. → Wet all cavities with bubble-free disinfectant.
3. → Remove the disinfectant residues or leave them to dry after using disinfectants.

#### Autoclaving

The following accessories may be autoclaved at 121 °C / 250 °F (20 min):

- Swing-out rotors
- Aluminium angle rotors
- Metal buckets
- Lid with bioseal
- Inserting

No statement can be made about the resulting degree of sterility.

The lids of the rotors and bucket must be removed before autoclaving.

Autoclaving accelerates the ageing of materials. It may cause changes in colour. After autoclaving, the rotors and accessories are to be visually inspected for damage and any damaged parts are to be replaced immediately.

The sealing ring in question is to be replaced if there are signs of cracking, embrittlement or wear. For lids with non-replaceable sealing rings, the whole lid must be replaced.

The sealing rings must be replaced after autoclaving to ensure the tightness of the biosafety systems.

## 8.5 Maintenance

### Greasing the rubber seal of the centrifuging chamber

- ➔ Rub the sealing ring lightly with a rubber care product.

### Greasing the rubber seal of the biosafety system

- ➔ Rub the sealing ring lightly with a rubber care product.

### Trunnion greasing

1. ➔ Remove accessories.
2. ➔ Clean the trunnions.
3. ➔ Remove any detergent residues with a damp cloth after using detergents.
4. ➔ Grease the trunnions and suspension with Hettich Tubenfett 4051.
5. ➔ Excess grease in the centrifuging chamber must be removed.

### Checking the accessories

1. ➔ The accessories shall be checked for wear and corrosion damage.
2. ➔ Check that the rotor is firmly seated.

### Checking the biosafety system

1. ➔ Visually check all parts of the biosafety system for damage.
2. ➔ Check the correct installation position of the sealing ring(s) of the biosafety system.
3. ➔ Replace the damaged parts of the biosafety system.
4. ➔ Replace the sealing ring in question immediately if there are signs of cracking, embrittlement or wear. For lids with non-replaceable sealing rings, the whole lid must be replaced.

### Centrifuging chamber damage inspection

- ➔ Check the centrifuging chamber for damage.

### Greasing the motor shaft

1. ➔ Remove accessories.
2. ➔ Clean the motor shaft.
3. ➔ Remove any detergent residues with a damp cloth after using detergents.

4. ➤ Grease the motor shaft with Hettich Tubenfett 4051.
5. ➤ Excess grease in the centrifuging chamber must be removed.

**Accessories with a limited service life**

The use of certain accessories is time-limited. For safety reasons, the accessories must no longer be used when either the maximum number of permissible run cycles marked on them or the expiry date marked on them has been reached.

- The maximum permissible number of run cycles or the expiry date can be seen on the accessories.

**Replacing centrifuge tubes**



**CAUTION**

**Risk of injury from broken glass.**

Broken glass may cause glass splinters and contaminated liquids to be found inside the centrifuge.

- Wear cut-resistant gloves.
- Wear protective goggles and a face mask.

Broken parts of the tube, glass splinters and spilled centrifuge material must be removed completely in the event of leakage or if a centrifuge tube breaks. Glass splinters that are not removed will cause further glass breakage.

The rubber inserts and the plastic sleeves of the rotors must be replaced after a glass breakage.

Disinfection must be carried out if the material is infectious.

## 9 Troubleshooting

### 9.1 Fault description

Customer service must be notified if the fault cannot be rectified based on the fault table. State the centrifuge type and serial number. Both numbers can be seen on the type plate of the centrifuge.

\* Error number does not appear on the display.

Fault description	Cause	Remedy
no display	No power. Overcurrent protection fuse has tripped.	<ul style="list-style-type: none"> <li>■ Check the supply voltage.</li> <li>■ Set the mains switch to <i>///</i>.</li> </ul>
TACHO - ERROR 1, 2, 96	Tacho defective. Motor, electronics defective.	<ul style="list-style-type: none"> <li>■ Open the lid.</li> <li>■ Set the mains switch to <i>/0/</i>.</li> <li>■ Wait at least 10 seconds.</li> <li>■ Turn the rotor vigorously by hand.</li> <li>■ Set the mains switch to <i>///</i>. The rotor must rotate while switching on.</li> </ul>
IMBALANCE 3*	The rotor is unevenly loaded.	<ul style="list-style-type: none"> <li>■ Open the lid.</li> <li>■ Check the loading of the rotor.</li> <li>■ Repeat the centrifugation run.</li> </ul>
CONTROL - ERROR 4, 6	Lid lock error.	<ul style="list-style-type: none"> <li>■ Perform a MAINS RESET.</li> </ul>

Fault description	Cause	Remedy
CONTROL - ERROR 8	Lid lock error	<ul style="list-style-type: none"> <li>■ Open the lid.</li> <li>■ Set the mains switch to [0].</li> <li>■ Wait at least 10 seconds.</li> <li>■ Turn the rotor vigorously by hand.</li> <li>■ Set the mains switch to [I]. The rotor must rotate while switching on.</li> </ul>
N > MAX 5	Overspeed.	<ul style="list-style-type: none"> <li>■ Perform a MAINS RESET.</li> </ul>
N < MIN 13	Underspeed.	<ul style="list-style-type: none"> <li>■ Perform a MAINS RESET.</li> </ul>
MAINS INTERRUPT 11*	Loss of mains power during the centrifugation run. The centrifugation run was not completed.	<ul style="list-style-type: none"> <li>■ Open the lid.</li> <li>■ Press the [START/IMPULS] button.</li> <li>■ If required: Repeat the centrifugation run.</li> </ul>
ROTORCODE 10.1, 10.2	Rotor coding error.	<ul style="list-style-type: none"> <li>■ Open the lid.</li> </ul>
CONTROL-ERROR 21, 22, 25, 27, 29	Error/defect in electronics.	<ul style="list-style-type: none"> <li>■ Perform a MAINS RESET.</li> </ul>
CONTROL-ERROR 23	Error/defect in control panel.	<ul style="list-style-type: none"> <li>■ Perform a MAINS RESET.</li> </ul>
SER I/O-ERROR 30, 31, 33, 36	Error/defect in electronics.	<ul style="list-style-type: none"> <li>■ Perform a MAINS RESET.</li> </ul>
°C * -ERROR 51-53, 55	Error/defect in electronics.	<ul style="list-style-type: none"> <li>■ Perform a MAINS RESET.</li> </ul>
FU/CCI-ERROR 60-64, 67, 68, 82-86	Error/defect in electronics/motor.	<ul style="list-style-type: none"> <li>■ Perform a MAINS RESET.</li> </ul>
SYNC-ERROR 90	Error/defect in electronics.	<ul style="list-style-type: none"> <li>■ Perform a MAINS RESET.</li> </ul>
SENSOR-ERROR 91-93	Error/defect in imbalance sensor.	<ul style="list-style-type: none"> <li>■ Perform a MAINS RESET.</li> </ul>
KEYBOARD-ERROR	Error/defect in control panel.	<ul style="list-style-type: none"> <li>■ Perform a MAINS RESET.</li> </ul>
NO ROTOR	No rotor installed.	<ul style="list-style-type: none"> <li>■ Open the lid and install the rotor.</li> </ul>
N > ROTOR MAX	Speed in the selected program greater than the maximum rotor speed.	<ul style="list-style-type: none"> <li>■ Check and correct the speed.</li> </ul>
N > ROTOR MAX	The rotor has been changed. The built-in rotor has a higher maximum speed than the previously used rotor, and it has not yet been detected by the rotor detection function.	<ul style="list-style-type: none"> <li>■ Set a speed up to the maximum speed of the previously used rotor. Press the [START/IMPULS] button to perform rotor detection.</li> </ul>
 The left half of the display lights up.	-	<ul style="list-style-type: none"> <li>■ Notify customer service.</li> </ul>

## 9.2 Performing a MAINS RESET

1.  Set the mains switch to [0].



2. → Wait 10 seconds.
3. → Set the mains switch to [//].

### 9.3 Emergency release

The lid cannot be unlocked by the motor in the event of a power failure. Emergency unlocking by hand must be performed.



**! WARNING**

**Risk of electric shock due to maintenance and servicing work on live device.**

- Disconnect the device from the mains before carrying out repairs and maintenance.



**WARNING**

**Danger of cutting and crushing due to moving rotor.**

- Do not open the lid until the rotor has stopped.

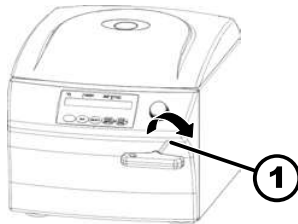

Fig. 22: Emergency release

1 Hole

**Personnel:**

- Trained user

1. → Look through the window in the lid to ensure that the rotor is stationary.
2. → Insert the hex key horizontally into the hole (1) and turn clockwise until the lid opens.
3. → Remove the hex key from the hole (1).
4. → Check whether the left side of the [STOP/OPEN] button flashes when power is restored.

When the left side of the [STOP/OPEN] button flashes, press the [STOP/OPEN] button so that the motorised lid lock assumes the home position (open) again.

## 10 Disposal

### 10.1 General instructions



***The device can be disposed of via the manufacturer.***

*A Return Material Authorisation (RMA) form must always be requested for a return.*

*If necessary, contact the Technical Service Department of the manufacturer:*

- **Andreas Hettich GmbH & Co. KG**
- Föhrenstraße 12
- 78532 Tuttlingen, Germany
- Phone: +49 7461 705 1400
- E-Mail: [service@hettichlab.com](mailto:service@hettichlab.com)

**! WARNING**

**Risk of pollution and contamination for people and the environment.**

When disposing of the centrifuge, people and the environment may be polluted or contaminated by incorrect or improper disposal.

- Removal and disposal may be carried out only by a trained and authorized service personnel.

The device is intended for the commercial sector ("Business to Business" - B2B).

According to Directive 2012/19/EU, the devices may no longer be disposed of with household waste.

The appliances are assigned to the following groups according to the Stiftung Elektro-Altgeräte Register (EAR (German foundation under civil law)):

- Group 1 (heat exchangers)
- Group 4 (large appliances)

The crossed-out wheelee bin symbol indicates that the device must not be disposed of with household waste. Regulations governing disposal of such devices may differ in individual countries. If necessary, contact the supplier.



*Fig. 23: Household waste ban*

## 11 Index

### A

Accessories. . . . .	15
biosafety systems. . . . .	37
disinfection. . . . .	37
the rotor. . . . .	38
with limited service life. . . . .	39

Autoclaving. . . . .	37
----------------------	----

### C

Care	
Intervals. . . . .	35

Centrifugation	
in continuous operation. . . . .	29
with higher substance density. . . . .	31
with time preselection. . . . .	30

Centrifuging chamber	
inspection. . . . .	38

Change	
program. . . . .	32

Checking	
the biosafety system. . . . .	38

Cleaning. . . . .	36
biosafety systems. . . . .	37

Cleaning and disinfection	
Instructions. . . . .	36

Connecting the centrifuge. . . . .	20
------------------------------------	----

Continuous operation. . . . .	29
-------------------------------	----

### D

Device	
biosafety systems. . . . .	36
disinfection. . . . .	37

Disinfection. . . . .	37
-----------------------	----

Disposal. . . . .	41
-------------------	----

### E

Enabling/disabling	
an audible signal. . . . .	35

Enter	
program. . . . .	32

Error messages. . . . .	39
-------------------------	----

### F

Fastening	
removal. . . . .	18
the transport lock. . . . .	17

Filling. . . . .	25
------------------	----

Foreseeable misuse. . . . .	6
-----------------------------	---

### G

General safety instructions. . . . .	7
--------------------------------------	---

Greasing	
the rubber seal. . . . .	38

### I

Intended use. . . . .	5
-----------------------	---

### L

Labels	
on the device. . . . .	13
on the packaging. . . . .	13

Lid	
the lid. . . . .	21

Loading. . . . .	25
------------------	----

### M

MAINS RESET. . . . .	40
----------------------	----

Maintenance. . . . .	38
Intervals. . . . .	35

### N

Non-intended use. . . . .	6
---------------------------	---

### O

Opening	
for programs. . . . .	32
programs. . . . .	32

Operator's responsibility. . . . .	7
------------------------------------	---

Original spare parts. . . . .	15
-------------------------------	----

### P

Personal protective equipment. . . . .	6
--	---

Personnel qualifications. . . . .	6
-----------------------------------	---

Personnel training. . . . .	7
-----------------------------	---

Protective equipment. . . . .	6
-------------------------------	---

### Q

Querying	
system information. . . . .	34

### R

Rating plate. . . . .	12
-----------------------	----

Relative centrifugal force	
RCF. . . . .	31

Removing	
the rotor. . . . .	22, 26

Replacing	
centrifuge tubes. . . . .	39

Return. . . . .	16
-----------------	----

Rotor detection. . . . .	33
--------------------------	----

### S

Safety instructions. . . . .	7
------------------------------	---

Scope of delivery. . . . .	16
----------------------------	----

Setting up the centrifuge. . . . .	19
------------------------------------	----

Short-term centrifugation. . . . .	30
------------------------------------	----

Spare parts. . . . .	15
----------------------	----

Storage conditions. . . . .	17
-----------------------------	----

Switching off. . . . .	21
------------------------	----

Switching the unit on. . . . .	21
--------------------------------	----

Symbols. . . . .	5
------------------	---

### T

Transport condition. . . . .	16
------------------------------	----

Troubleshooting. . . . .	39
--------------------------	----

Trunnion	
greasing. . . . .	38



**U**

Unpacking. . . . . 18