



SpectraMax® iD3

Multi-Mode Microplate Reader

Installation Guide

This document is provided to customers who have purchased Molecular Devices equipment, software, reagents, and consumables to use in the operation of such Molecular Devices equipment, software, reagents, and consumables. This document is copyright protected and any reproduction of this document, in whole or any part, is strictly prohibited, except as Molecular Devices may authorize in writing.

Software that may be described in this document is furnished under a non-transferrable license. It is against the law to copy, modify, or distribute the software on any medium, except as specifically allowed in the license agreement. Furthermore, the license agreement may prohibit the software from being disassembled, reverse engineered, or decompiled for any purpose.

Portions of this document may make reference to other manufacturers and/or their products, which may contain parts whose names are registered as trademarks and/or function as trademarks of their respective owners. Any such usage is intended only to designate those manufacturers' products as supplied by Molecular Devices for incorporation into its equipment and does not imply any right and/or license to use or permit others to use such manufacturers' and/or their product names as trademarks. Each product is shipped with documentation stating specifications and other technical information. Molecular Devices products are warranted to meet the stated specifications. Molecular Devices makes no other warranties or representations express or implied, including but not limited to, the fitness of this product for any particular purpose and assumes no responsibility or contingent liability, including indirect or consequential damages, for any use to which the purchaser may put the equipment described herein, or for any adverse circumstances arising therefrom. The sole obligation of Molecular Devices and the customer's sole remedy are limited to repair or replacement of the product in the event that the product fails to do as warranted.

For research use only. Not for use in diagnostic procedures.

The trademarks mentioned herein are the property of Molecular Devices, LLC or their respective owners. These trademarks may not be used in any type of promotion or advertising without the prior written permission of Molecular Devices, LLC.

Patents: <http://www.moleculardevices.com/patents>

Product manufactured by Molecular Devices, LLC.
3860 N. First Street, San Jose, California, 95134, United States of America.
Molecular Devices, LLC is ISO 9001 registered.
©2018 Molecular Devices, LLC.
All rights reserved.



Contents

Chapter 1: Setting Up the Instrument	4
Package Contents	5
Unpacking the Instrument	7
Removing the Transport Locks	9
Connecting Instrument Cables	12
Assembling Injectors	13
Getting Started	17
Defining Date, Time, and Global Read Settings	18
Getting the Instrument On Your Network	19
Installing the QuickSync Tool	20
Chapter 2: Before You Move the Instrument	22
Installing Transport Locks	24

Chapter 1: Setting Up the Instrument

Before you unpack and setup the SpectraMax® SpectraMax iD3 Multi-Mode Plate Reader, prepare a dry, flat work area that has sufficient space for the instrument and required cables. All software required to run basic non-injector reads is installed in the instrument and is accessible from the touchscreen.

You can export data to a computer over your intranet, through a direct Ethernet cable, or to a USB flash drive in an Excel format for further analysis.

You must use a computer running the SoftMax® Pro Software to operate the instrument for advanced acquisition settings and for protocols that use the SpectraMax® Injector System with SmartInject™. See the *SoftMax Pro User Guide*.

The SoftMax Pro Software installation automatically installs the QuickSync tool. You can choose to install only the QuickSync tool.



Note: When you use a computer running the SoftMax Pro Software to operate the instrument, the instrument touchscreen is locked.

The SoftMax Pro Software installation places a copy of the available microplate reader user guides (.pdf) in the following location on the computer:

C:\ProgramData\Molecular Devices\User Guides







The most recent version of the microplate reader user guides and the *SoftMax Pro Data Acquisition and Analysis Software User Guide* are available on the Molecular Devices Knowledge Base:

In the software, select the **Home** tab, click **Contact Us**, and then select **Knowledge Base**.

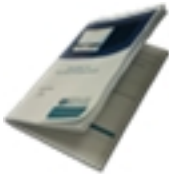
Or go to www.moleculardevices.com/service-support.

Package Contents

The package contains the instrument plus a box that contains the tools and accessories required to install the instrument.

Illustration	Part Number	Description
	Latest Version	SoftMax Pro Software with Product Key and QuickSync tool
	5054744	Installation guide
	YW 000 006	Hex key, 2.0 mm
	YW 000 012	Holex HEXAGON ballhead bolt driver 3 mm
	5052189	CAT6 Ethernet cable, 2 meter (6.56 foot)
	4400-0002 or 4400-0036	Power cord, 115 V or Power cord, 230 V
	5061514	Near Field Communication (NFC) magnets.
	5056339	Near Field Communication (NFC) key fob (NTAG 213, 180 byte).

When your instrument has the SpectraMax Injector System the package also contains the following.

Package Contents For Injectors

Illustration	Part Number	Description
	5055247	Injector Nozzle
	5044164	Tubing
	5055251	Bottle Holder
	5044165	Bottle Adapters
	5044163	Waste Plate
	Cannot order from Molecular Devices Wide-neck bottle, HDPE 50 mL capacity 36 mm square by 68 mm high 24 mm diameter inside neck Recommended supplier: VWR (215-0440)	Bottles
	Cannot order from Molecular Devices Strip wells, polystyrene 1x8, clear, flat-bottomed Recommended supplier: Greiner Bio-One (762001)	Strip well

For a complete list of the contents of the package, see the enclosed packing list.

Unpacking the Instrument

The packaging is designed to protect the instrument during transportation.

Transport locks are placed on the transport slide and the plate drawer to protect the instrument from damage during shipment. You must remove the transport locks before you power on the instrument.



WARNING! LIFTING HAZARD. To prevent injury, use a minimum of two people to lift the instrument.



Note: Retain the shipping box and all packaging materials for future transport needs. Do not use tools that can damage the packaging or the instrument.



CAUTION! When transporting the instrument, warranty claims are void if improper packing results in damage to the instrument.

To unpack the instrument:

1. Check the box for damage that occurred during transportation. Inform the supplier immediately and keep the damaged packaging.
-



CAUTION! Keep the box upright. Do not tip or tilt the box or place it on its side.

2. With the box facing up as indicated, cut open the side of the box labeled **Open Here**.



3. Grasp the handle on the cardboard and slide the instrument out of the box.

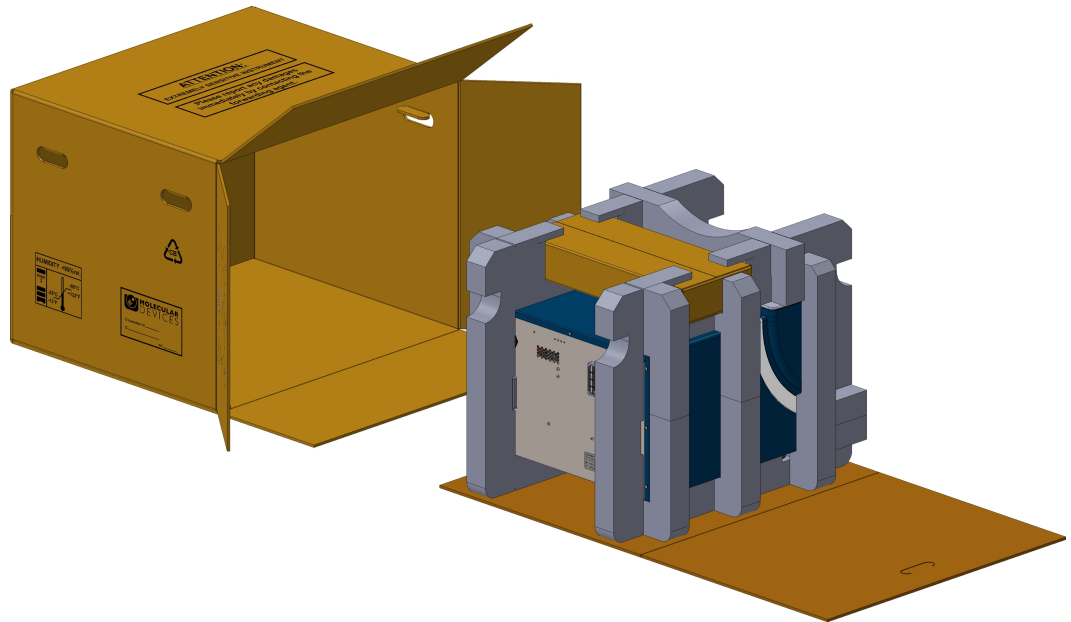

4. Remove the accessories tool box.

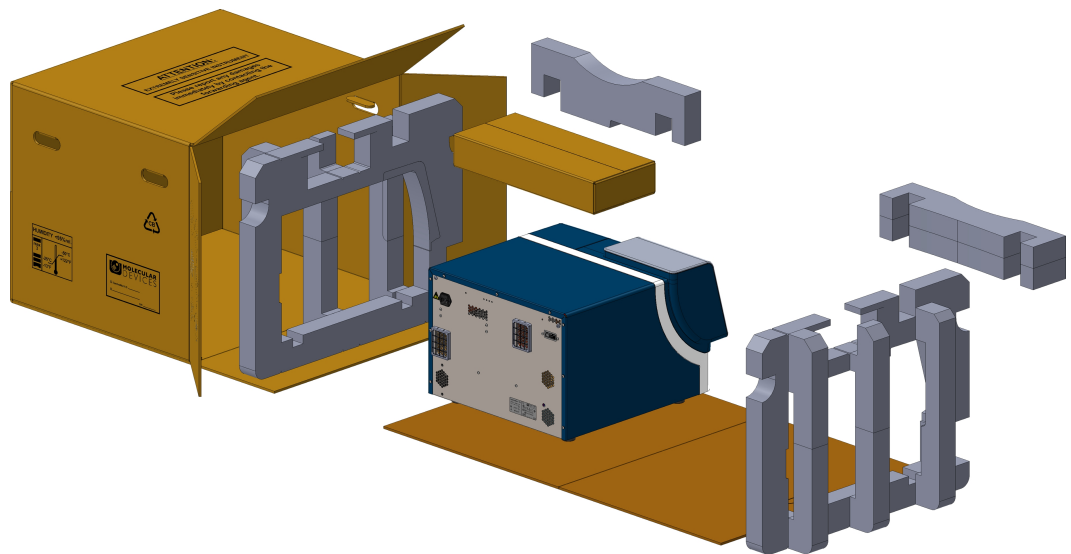

CAUTION! Keep the instrument upright and level when lifting. Do not tip or shake the instrument to prevent damage to the instrument.

5. Remove the foam packaging from both ends and then remove the plastic bag from the instrument.
6. With one person on each end, lift the instrument to a dry, flat area. You will need to access the back of the instrument to remove the transport lock and to connect the instrument cables.



Removing the Transport Locks



CAUTION! The instrument can be damaged if the transport locks are not removed before the instrument is powered on.

Transport locks are placed on the transport slide and the plate drawer to protect the instrument during shipment.

Required Tools

Illustration	Part Number	Description
	YW 000 006	Hex key, 2.0 mm
	YW 000 012	Holex HEXAGON ballhead bolt driver 3 mm



CAUTION! Do not touch or loosen screws or parts other than those specifically designated in the instructions. Doing so could cause misalignment and possibly void the warranty.

To remove the transport lock:

1. Remove the black cover from the travel lock opening in the center on the rear of the instrument. This cover prevents high dark counts for Luminescence reads and will be put back in after the following step.

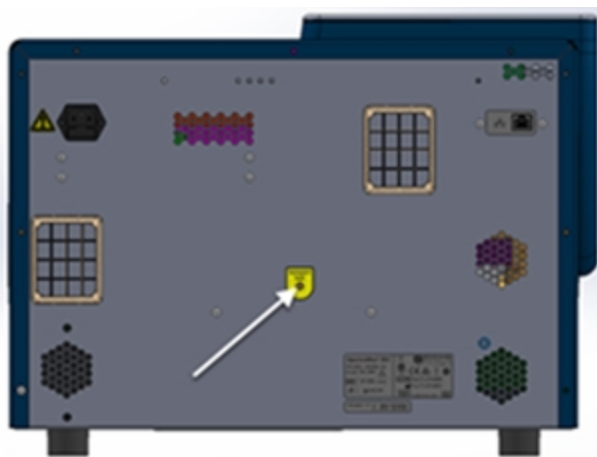

2. Use the provided 3.0 mm Horex HEXAGON ballhead bolt driver to loosen the screw located inside the Transport Lock opening until you feel the spring release.



Note: The screw remains inside the instrument. The screw is spring mounted and cannot get lost within the instrument. It could take ten full turns to loosen the screw until you feel the spring release. This unlocks the transport slide. If the instrument makes a grinding noise when you start a plate read, you have not released the transport slide.

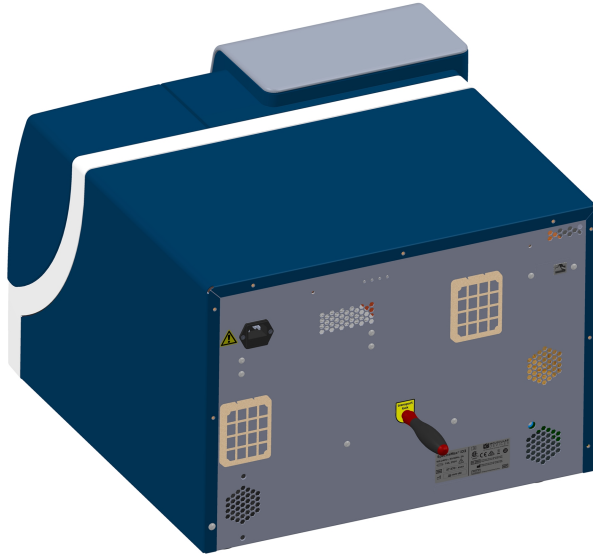

3. Replace the black cover in travel lock opening. This cover prevents high dark counts for Luminescence reads.
4. On the front of the instrument, gently pull the yellow tab protruding from the plate chamber door to open the door. You must hold the plate drawer door open while you remove the transport lock.



Note: Be careful not to tear the yellow tab. It must remain attached to the transport lock to make it easier to open the plate chamber door.

5. Use the provided 2.0 mm hex key to loosen screw #1 in the upper-left corner of the transport lock until the lock disconnects from the instrument frame. The screw has a retaining washer that prevents it from being removed from the lock.



Tip: After you loosen screw #1, pull the plate drawer slightly out of the instrument to hold the chamber door open.

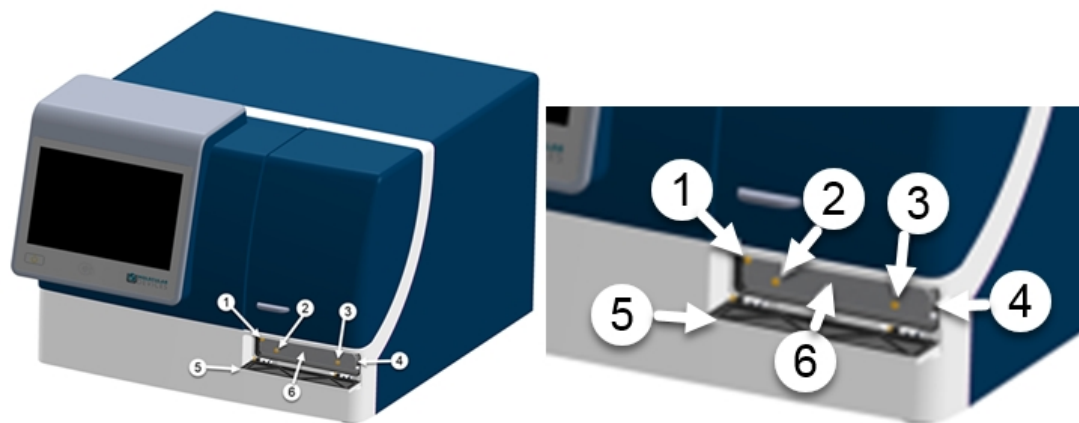

Plate Drawer Transport Lock



Item	Description
1	Screw #1 fastens the lock to the internal frame of the instrument
2	Screw #2 fastens the lock to the plate drawer
3	Screw #3 fastens the lock to the plate drawer
4	Plate drawer
5	Plate door in open position
6	Plate drawer transport lock

- Loosen screws #2 and #3 until the lock comes free of the plate drawer and you can remove the lock from the instrument. The screws have retaining washers that prevent them from being removed from the lock. Store the transport lock in the accessories tool box included with the microplate reader.
- Push the plate drawer back inside the instrument and close the chamber door.
- Save the original carton, foam inserts, accessories tool box, and transport locks for future shipments.

Connecting Instrument Cables

The power cord and Ethernet cable connect to the ports on the rear of the instrument. The Ethernet port enables you to connect the instrument to your intranet (similar to a printer) or to connect the instrument directly to a computer. When the instrument is connected to your intranet, you can synchronize any computer on the same intranet with the instrument, within security and firewall restrictions. You can synchronize multiple computers to an instrument and multiple instruments to a computer over your intranet.

Required Accessories

Illustration	Part Number	Description
	5052189	CAT6 Ethernet cable, 2 meter (6.56 foot)
	4400-0002 or 4400-0036	Power cord, 1 meter (3.3 foot)

To connect the cables to the instrument:

1. Connect one end of the supplied Ethernet cable to the Ethernet port on the instrument and then connect the other end of the Ethernet cable to a network wall outlet.

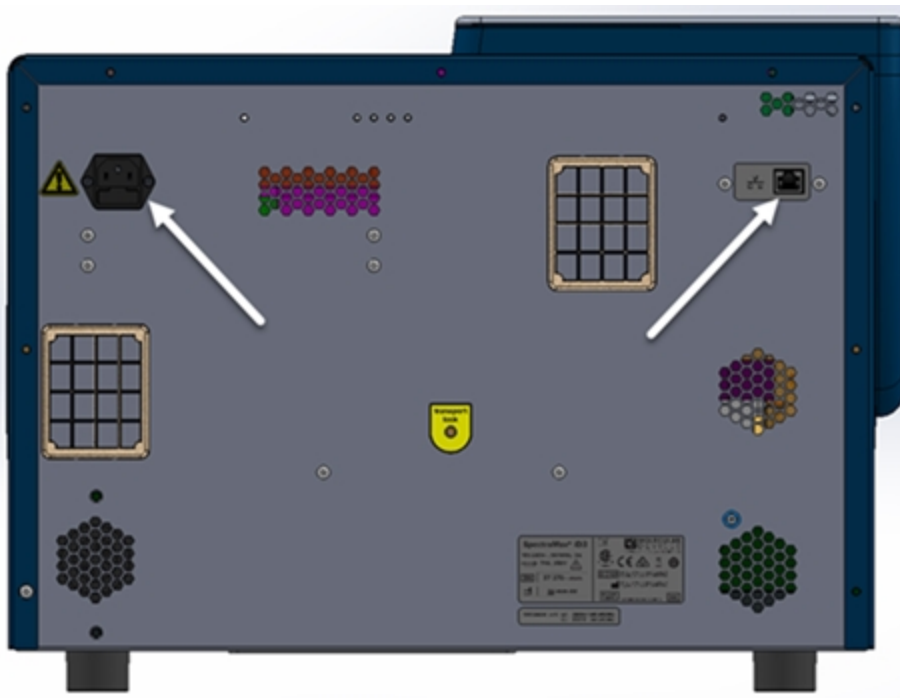

2. Use the power cord supplied with the instrument to connect the instrument to a grounded electrical wall outlet.

You can optionally connect the instrument directly to a computer.

1. Turn on the power to the computer.
2. Connect one end of an Ethernet cable to the port on the rear of the instrument and then connect the other end of the Ethernet cable to the Ethernet port on the computer. If the computer to which you intend to directly connect the instrument does not have an available Ethernet port, you can use an Ethernet (instrument side) to USB (computer side) adapter. (Adapter not included.)

Assembling Injectors

The SpectraMax Injector System is an optional addition to the base instrument configuration. If there is no handle on the instrument right hood, your instrument does not have injectors and the right hood is sealed shut.

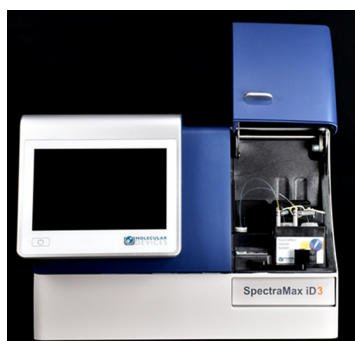

The two injectors are located under the instrument right hood. Injector 1 is on the left and injector 2 is on the right as you face the instrument.

Bottle Holder



The bottle holder is mounted on two knobs.

1. Align the two slots on the bottle holder with the two pegs on the rail.
2. Lightly press the bottle holder into position.

Injector Tubing

Each injector has an injector tube. The tubing line connects to an injector tip on one end and a snorkel on the other end. From the tip, the tube passes around the injector pump to the snorkel. The tubing around the pump is held in position by two rubber bumpers and a stabilizer lid.

To deliver reagent, the SpectraMax Injector System uses peristaltic pumps. Peristaltic pump systems use rotors with rollers that compress and relax flexible tubing. Reagent enters the relaxed tubing and is then pushed through as the rotating roller compresses the tubing. Alternate relaxing and compressing of the tubing results in a continuous stream of reagent passing through the tubing.



Note: Over long periods of injector use, the elasticity of the tubing may decline and the volume delivered per pump turn may become smaller.

The dispense accuracy should be periodically verified by running the gravimetric tubing calibration procedure. When you replace worn out tubing, you should perform a before and after calibration to ensure consistent results.

When not in use for long periods of time, open the stabilizer lids on top of the pumps to relieve compression on the tubing. This helps to retain uniformity of the tubing and ensure repeatability. Before use, make sure you close the stabilizer lids.

The tips slide into the nozzle. Move the nozzle to the injector arm above the open plate drawer for wash and prime functions. Move the nozzle to the opening located in the back left of the injector space within the instrument for injector protocols.

The snorkels are held in the bottles by snorkel clamps.

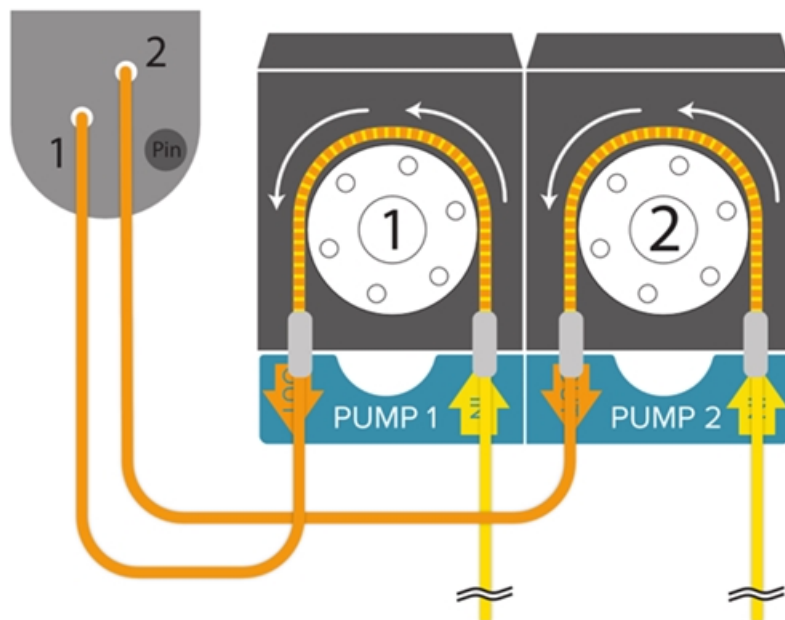

To install or replace the injector tubing:

1. Move the injector arm away from the instrument and insert the nozzle into the injector arm.

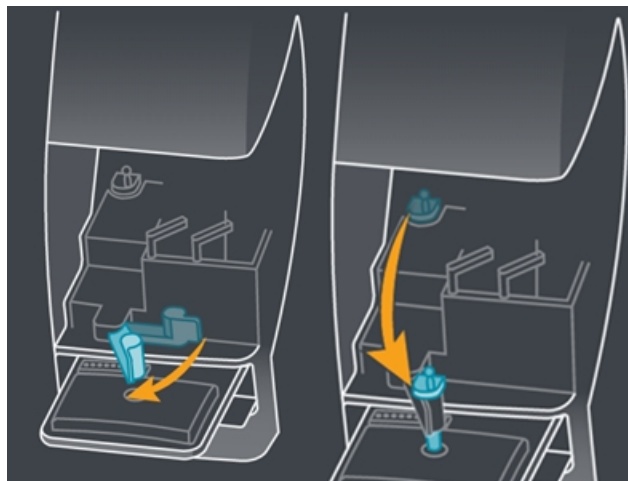

Do the following for both injectors.

2. Insert the snorkel into the bottle and then insert the snorkel into the snorkel clamp. Clamp for injector 1 is on the left and clamp for injector 2 is on the right.

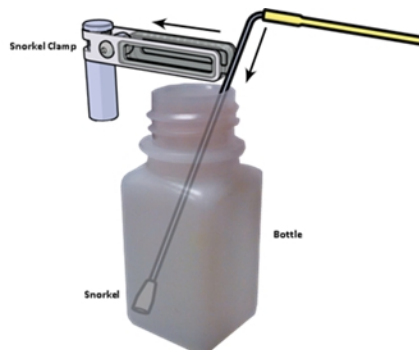

3. Pump 1 is on the left and pump 2 is on the right. Lift the stabilizer lid over the pump, press the bumper into the bumper slot on the input (right) side of the injector pump, gently pull the tubing around the injector pump, and then seat the bumper on the output (left) side of the injector pump.

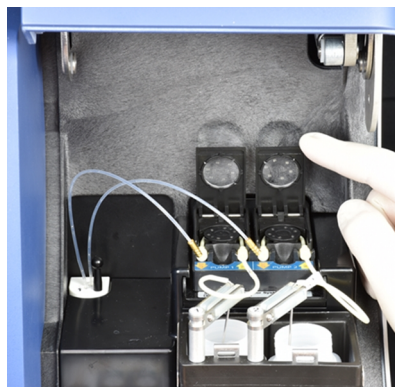

- Slide the tip into the nozzle, the slots are labeled 1 and 2 for injector 1 and injector 2.



- Use the black knob to move the nozzle back to the rear of the injector space. Align the nozzle with the opening and press straight down until you feel it snap into place.



- Move the injector arm to its original position.

Getting Started

All software required to run basic non-injector reads is installed in the instrument and is accessible from the touchscreen. You must use a computer running the SoftMax Pro Software to operate the instrument for advanced acquisition settings and for protocols that use the SpectraMax Injector System. Near Field Communication (NFC) tags enable you to easily save and view the protocols that matter to you.

The power button and NFC sensor are directly below the touchscreen on the front of the instrument.



CAUTION! You must remove the transport locks before you power on the instrument. See [Removing the Transport Locks on page 9](#).

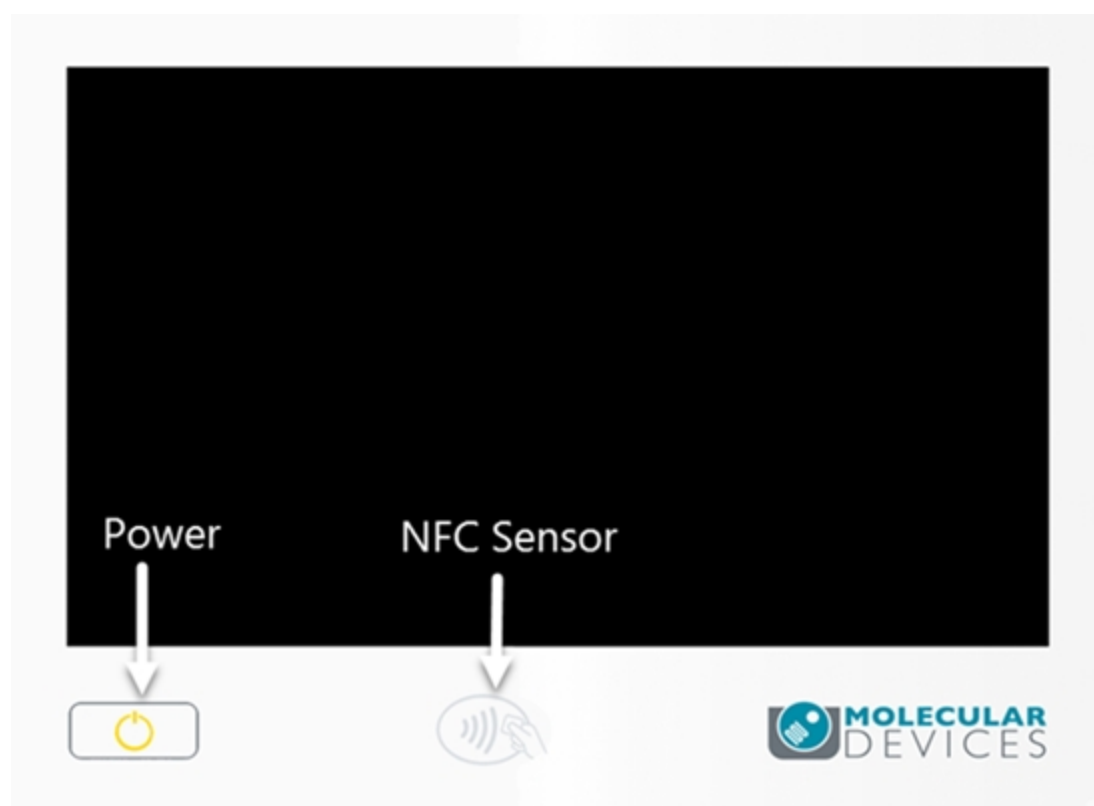

To power on the instrument:

1. Press the power button below the touchscreen.
2. Wait until the Welcome page displays and the  disappears.







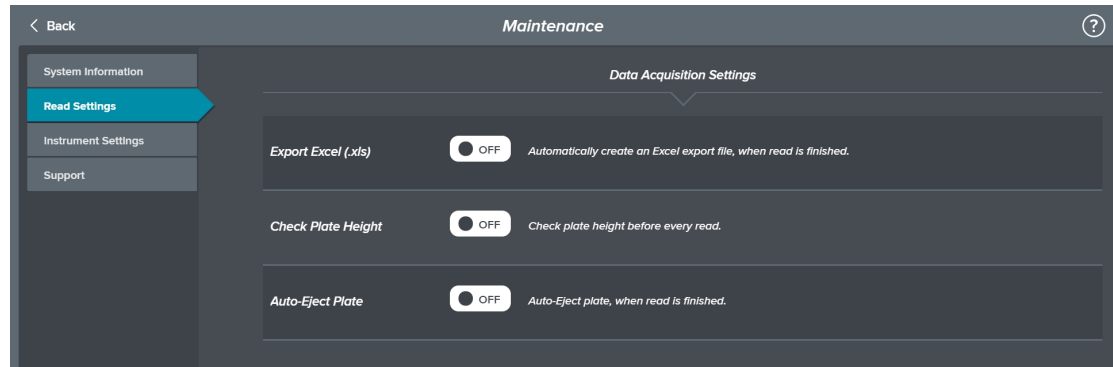

Note: When the instrument has fully initialized, the  icon on the left displays a temperature.

Defining Date, Time, and Global Read Settings

The Maintenance page enables you to define high-level read settings and the system date and time.



You need to log in (as any user) to change the date, time, and read settings. These settings are global and apply to all users of the instrument.

1. On the Welcome page, touch the **Public** user to display the Home page.
2. From the buttons on the left, touch  to display the Maintenance page and touch the **Read Settings** tab.
 - Touch the **Export Excel**  to display  to have the instrument export data through an Ethernet cable to a computer that is on the same company network or is attached to the instrument. You must insert a USB flash drive into the slot below the touchscreen or install the QuickSync tool on the computer.
 - Touch the **Check Plate Height**  to display  to have the instrument check the plate height before reads.
 - Touch the **Auto-Eject Plate**  to display  to have the instrument open the plate drawer after each read completes.
3. Touch **Instrument Settings** to display the Instrument Settings tab.

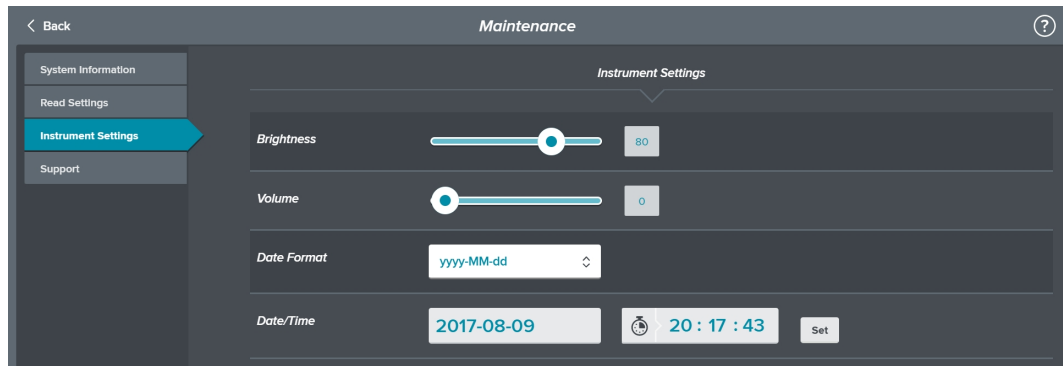

4. Use the **Brightness** slider to adjust the brightness of the touchscreen.

5. Use the **Volume** slider to change the volume of the instrument speakers that play the how-to videos. How-to videos are on the Support tab.
6. Touch the **Date Format** drop-down and select a format for date and time display.
7. Touch in the **Date/Time** field to display a calendar. Use the calendar to change the system date then touch the clock and use the scroll bars to change the time.
8. Touch **Set** to save the date/time changes.



Note: When you change the system date and time, the instrument software does an application re-start.

Getting the Instrument On Your Network

After you connect the Ethernet cable from the instrument to a networked wall outlet and after you power on the instrument, the instrument should automatically have an IP address assigned.

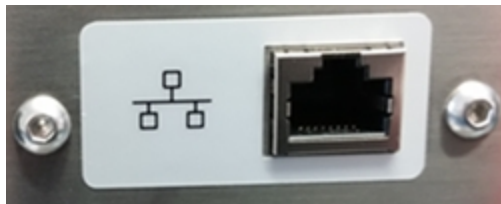

Tip: You might have to work with your IT department to make sure your network will accept the addition of the instrument.

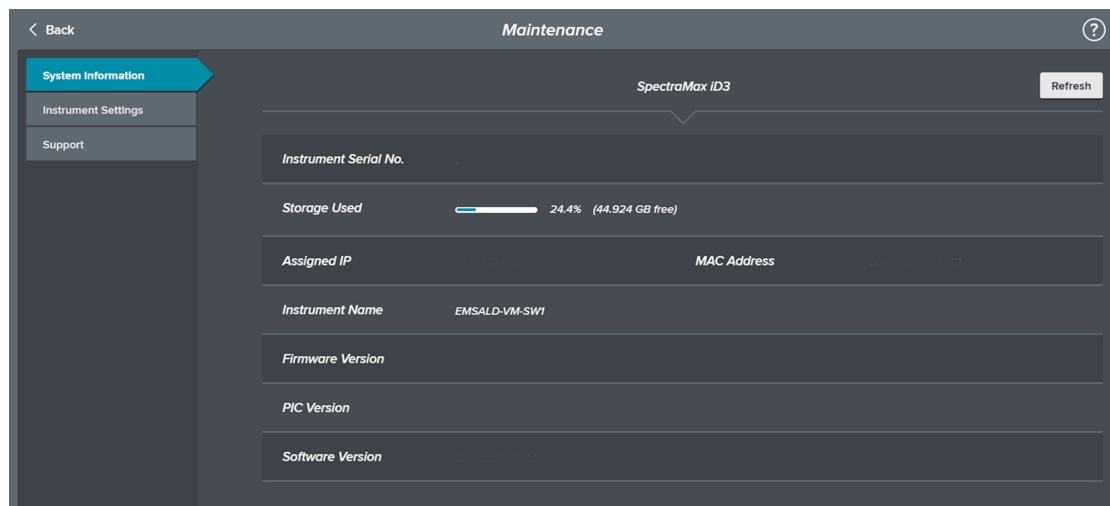

The Maintenance page has a System Information tab that enables you to view the instrument IP address. You do not need to log in as a user for this workflow.

1. From the buttons on the left, touch  to display the Maintenance page.
2. Touch **System Information** to display the System Information tab.

3. Touch **Refresh**. The instrument IP address can change due to network interruptions or when you power off the instrument. **Refresh** updates the display of the Assigned IP address.
4. The **Assigned IP** field displays the instrument IP address.



Note: If you plan to use a computer running the SoftMax Pro Software to operate the instrument, write down the IP address. You may need the IP address to connect the computer to the instrument.

Installing the QuickSync Tool

The QuickSync tool is optional and enables a computer to receive the raw data that the instrument exports, within the security and firewall restrictions of your network. The computer must be able to communicate with the instrument over your intranet or you can directly connect the computer to the instrument. After you synchronize the computer with the instrument, the instrument exports result data to the computer for further analysis.



Note: When you install the SoftMax Pro Software on a computer, the SoftMax Pro Software installation process automatically installs the QuickSync tool.

This topic describes how to install just the QuickSync tool on a computer, without installing the SoftMax Pro Software.







Tip: You can synchronize multiple computers to an instrument and multiple instruments to a computer.

Required Accessory

Part Number	Description
Latest Version	SoftMax Pro Software with Product Key and QuickSync tool

To install only the QuickSync tool, do the following on the computer to which you want to export data.

1. Insert the supplied USB flash drive or CD into your computer.
2. Navigate the file hierarchy to locate the **QuickSync<x.x>.exe** file.
3. Double-click **QuickSync<x.x>.exe** to start the QuickSync tool installation wizard.
4. Select the **I accept the terms of the license agreement** check box and click **Next**.
5. Wait for the installation to complete and the success message appears.
6. Click **Finish**.
7. The  QuickSync icon appears in your computer taskbar area, with the other programs running on your computer, at the bottom of the screen. You may have to look in the Show Hidden Icons area.

- Click the big  in the taskbar to display a smaller version of the  in the computer tray near the clock at the bottom of the computer screen with the message "Scanning For Devices". Wait for the computer to find the instrument.
- Right-click  in the tray near the clock to display a menu and select **Available Services** to display the list of SpectraMax iD3 Multi-Mode Microplate Reader instruments on your intranet and/or the instrument to which you connect the computer through an Ethernet cable.

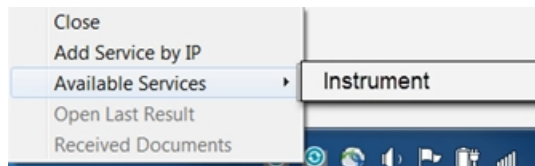

- Click the name of instruments to which to synchronize the computer. A check mark appears next to each instrument name to which the computer is synchronized.

Add Service by IP Address

If the name of the instrument does not appear in the list of available services, do the following:

- Right-click  in the tray near the clock and select **Add Service by IP** to display the following.

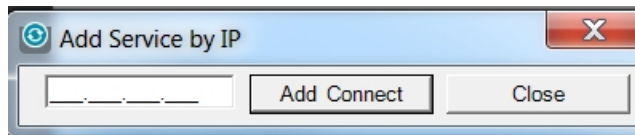

- Enter the IP address of the instrument to which to connect.
- Click **Add Connect**.

 **Tip:** If the computer still cannot find the instrument, contact your IT help desk to make sure that your company network setup and company intranet security allow the communication between the computer and the instrument.

Chapter 2: Before You Move the Instrument

When you move the instrument from one location to a new location, there are several things you must do before you power off the instrument.

This procedure requires the following tool included in the accessories tool box:



WARNING! LIFTING HAZARD. To prevent injury, use a minimum of two people to lift the instrument.

Illustration	Part Number	Description
	YW 000 012	Hollex HEXAGON ballhead bolt driver 3 mm



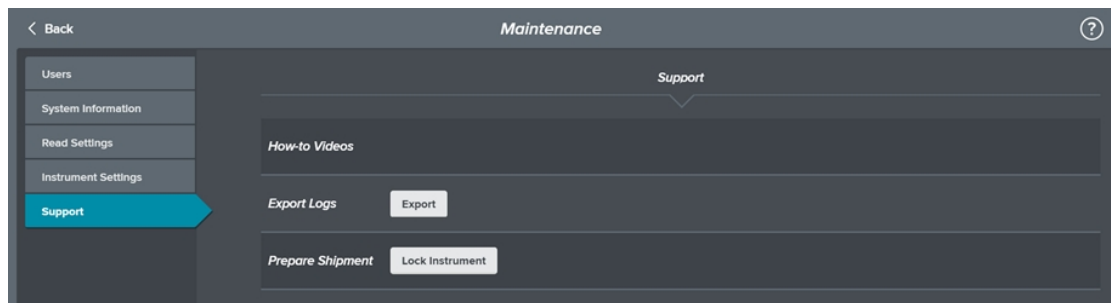

CAUTION! When transporting the instrument, warranty claims are void if improper packing results in damage to the instrument.



If you directly connect a computer to the instrument, make sure that the SoftMax Pro Software is not running and turn off the computer.

Before you power off the instrument, do the following to prepare the instrument for a move.

1. Touch  and remove the plate from the plate drawer, if present.
2. Touch  to display the Maintenance page.
3. Touch **Support** to display the Support tab.
4. Touch **Lock Instrument** to move the transport slide into a position that can accept the transport lock.
5. You are prompted to confirm that there is no plate in the drawer. When there is no plate in the drawer, touch **OK**.

6. On the rear of the instrument, remove the black cover from the travel lock opening in the center.

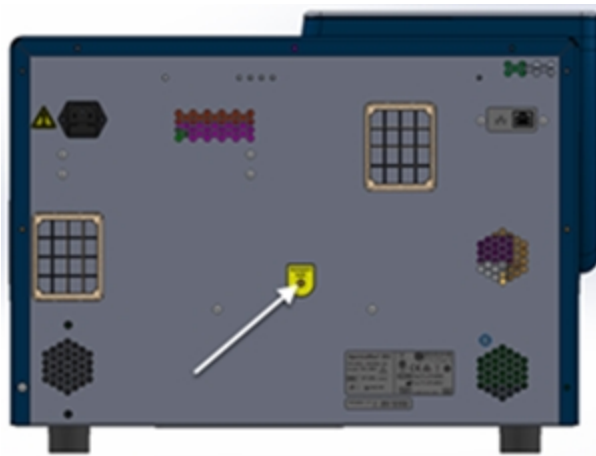

7. Insert the 3.0 mm Horex HEXAGON ballhead bolt driver into the Transport Lock opening and tighten the interior screw into the transport slide.

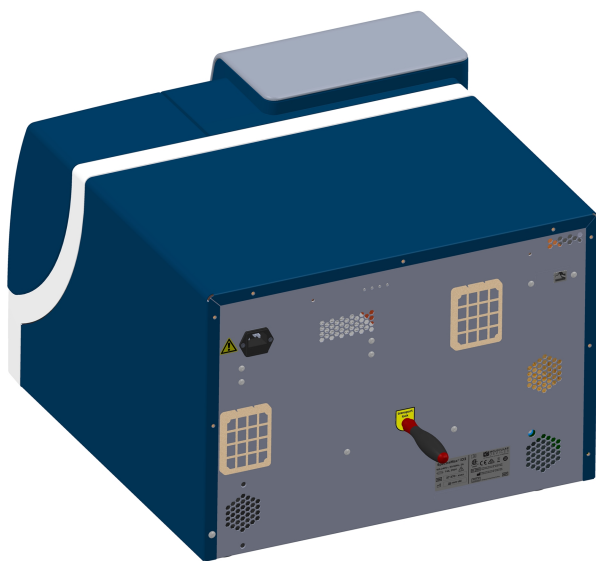

Note: The screw remains inside the instrument. The screw is spring mounted and cannot get lost within the instrument. Tighten the screw until it is snug. This locks the transport slide.

8. Replace the black cover in travel lock opening.
9. Move to the front of the instrument and touch **OK** to confirm that the transport slide has been locked. The plate drawer opens to enable you to install the transport lock on the plate drawer and the instrument proceeds to shut down.
10. Unplug the power cord and Ethernet cable from the rear of the instrument and from the wall outlet. Store the power cord and Ethernet cable in the accessories tool box.

11. Install the transport lock on the plate drawer. See [Installing Transport Locks on page 24](#).
12. If you plan to store the instrument, ship the instrument, or transport the instrument to a different building, pack the instrument in the original packaging.
13. Make sure that the new location is a dry, flat work area that has sufficient space for the instrument and required cables.

Installing Transport Locks

The transport locks protects the instrument from damage during a move or shipment.



CAUTION! Do not touch or loosen screws or parts other than those specifically designated in the instructions. Changes to other screws or parts can cause misalignment and possibly void the warranty.

This procedure requires the following tool included in the accessories tool box:

Illustration	Part Number	Description
	YW 000 006	Hex key, 2.0 mm

When you do all the steps in [Before You Move the Instrument on page 22](#) section, the transport slide moves to the correct position, you lock the transport slide, the plate drawer door opens, and the plate drawer moves into the position to accept the transport lock.

If you did not insert the 3.0 mm Horex HEXAGON ballhead bolt driver into the Transport Lock opening and tighten the interior screw into the transport slide you must power on the instrument and perform the steps in the [Before You Move the Instrument on page 22](#) topic.

To install the transport lock on the plate drawer:

1. Place the plate drawer transport lock on the end of the plate drawer.
2. Use the 2.0 mm hex key to tighten screws #2 and #3 until the lock is attached to the plate drawer.

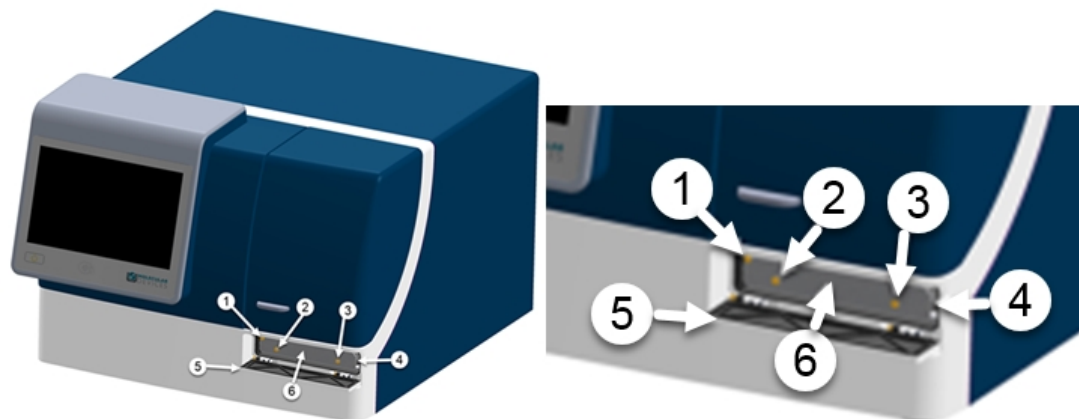

Plate Drawer Transport Lock

Item	Description
1	Screw #1 fastens the lock to the internal frame of the instrument
2	Screw #2 fastens the lock to the plate drawer
3	Screw #3 fastens the lock to the plate drawer
4	Plate drawer
5	Plate door in open position
6	Plate drawer transport lock

3. Gently push the plate drawer into the instrument and as far to the left as possible until screw #1, which fastens the lock to the internal frame of the instrument, lines up with the hole on the internal frame. The plate door must be held open manually until you fasten the transport lock.
4. Tighten screw #1 until the plate drawer is securely locked in place.
5. Route the yellow tab connected to the transport lock so that it will pass over the top of the plate door when the door is closed.
6. Gently close the plate door.

Contact Us

Phone: [+1-800-635-5577](tel:+18006355577)
Web: moleculardevices.com
Email: info@moldev.com

Visit our website for a current listing of worldwide distributors.