



Guide to Operations

innova[™] 4300

Digital Incubator Shaker

MANUAL No. M1193-0050

Revision R

August 5, 2002

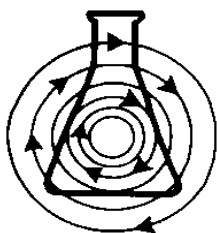

NEW BRUNSWICK SCIENTIFIC CO., INC.

BOX 4005 • 44 TALMADGE ROAD • EDISON, NJ 08818-4005

Telephone: 1-732-287-1200 • 1-800-631-5417

Fax: 732-287-4222 • Telex: 4753012 NBSCO

Internet: <http://www.nbsc.com> • E-mail: bioinfo@nbsc.com

INTERNATIONAL OFFICES:

THE NETHERLANDS

New Brunswick Scientific BV
Kerkenbos 1101, 6546 BC Nijmegen
P.O Box 6826, 6503 GH Nijmegen
Holland
Tel: 31 (0)24 3717 600
Fax: 31 (0)24 3717 640
E-mail: sales@nbsbv.nl

FRANCE

New Brunswick Scientific SARL
3, rue des Deux-Boules
75001 Paris
France
Tel: 33 (0)1 4026 2246
Fax: 33 (0)1 4026 5423
E-mail: sales@nbssarl.fr

UNITED KINGDOM

New Brunswick Scientific (UK) Ltd.
Edison House, 163 Dixons Hill Road
North Mymms, Hatfield, Herts. AL9 7JE
United Kingdom
Tel: 44 (0)1707 275733
Fax: 44 (0)1707 267859
E-mail: bioinfo@nbsuk.co.uk

BELGIUM

New Brunswick Scientific NV/SA
't Veldeke 1
B-1970 Wezembeek-Oppem
België/Belgique
Tel: 32 (0)2 731 6787
Fax: 32 (0)2 731 8130
E-mail: sales@nbsnv-sa.be

GERMANY

New Brunswick Scientific GmbH
In Der Au 14
D-72622 Nürtingen
Deutschland
Tel: 49 (0)7022 932490
Fax: 49 (0)7022 32486
E-mail: sales@nbsgmbh.de

CHINA

New Brunswick Scientific Co., Inc.
9A. AiBang Building
585 LingLing Road
Shanghai 200030, P.R. China
Tel: 86 21 6481 2658
Fax: 86 21 6481 2665
E-mail: nbschc@online.sh.cn

THIS PAGE INTENTIONALLY BLANK

**CAUTION!**

This equipment *must* be operated as described in this manual. If operational guidelines are not followed, equipment damage and personal injury *can* occur. Please read the entire User's Guide before attempting to use this unit.

THIS PAGE INTENTIONALLY BLANK

Copyright Notice

New Brunswick Scientific Company, Inc.
Box 4005 44 Talmadge Road
Edison, New Jersey 08818-4005

© Copyright 2002 New Brunswick Scientific Co., Inc.

All Rights Reserved.

Reproduction, adaptation, or translation without prior written permission
from

New Brunswick Scientific is prohibited.

Disclaimer Notice

New Brunswick Scientific Co., Inc. reserves the right to change information in this document without notice. Updates to information in this document reflect our commitment to continuing product development and improvement.

Manual Conventions



NOTE:

Notes contain essential information that deserves special attention.



CAUTION!

Caution messages appear before procedures which, if caution is not observed, could result in damage to the equipment.

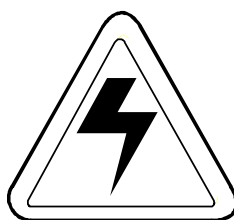

WARNING!

Warning messages alert you to specific procedures or practices which, if not followed correctly, could result in serious personal injury.

Bold

Text in bold face type emphasizes key words or phrases.

THIS PAGE INTENTIONALLY BLANK



WARRANTY

Innova Shakers are warranted by New Brunswick Scientific Co., Inc. for two years or 10,000 hours of actual shaker use, whichever comes later. This warranty covers parts and labor for the entire machine, with the exception of glassware and its contents. This warranty covers faulty components and assembly, and our obligation under this warranty is limited to repairing or replacing the shaker or part thereof which shall, within two years after date of shipment or 10,000 hours of operating time, prove to be defective after examination. This warranty does not cover any loss of time, materials, biological or biochemical by-products caused by any work interruption resulting from shaker failure, nor does it extend to any Innova Shaker which has been subjected to misuse, neglect, accident or improper installation or application. In addition, the warranty does not apply to any Innova Shaker that has been repaired or altered outside the NBS factory without prior authorization from New Brunswick Scientific. For a period of two years (or more) after the shipment date, the Innova warranty will be in effect as long as the shaker has not been in operation for a total of 10,000 hours. After the 10,000 hours of operating time have elapsed, the Innova warranty may still be in effect, as long as the two-year minimum warranty period has not been reached. Operating time is based on actual usage of the shaker, as determined by the shaker's internal electronic clock. Any tampering or alteration of the clock will void the 10,000-hour warranty.

THIS PAGE INTENTIONALLY BLANK

TABLE OF CONTENTS

| | | |
|----------|--|-----------|
| 1 | INTRODUCTION..... | 1 |
| 2 | OVERVIEW & FEATURES | 3 |
| 2.1 | GENERAL DESCRIPTION..... | 3 |
| 2.2 | UNIVERSAL POWER CAPABILITY | 5 |
| 2.3 | CONTROL PANEL | 6 |
| 2.3.1 | <i>LED Display</i> | 6 |
| 2.3.2 | <i>User Interface Keys</i> | 6 |
| 2.3.3 | <i>Status Indicator Lights</i> | 7 |
| 2.3.4 | <i>Function Indicator Lights</i> | 8 |
| 2.4 | PLATFORM ASSEMBLIES | 8 |
| 2.5 | QUICK-CHANGE PLATFORM KIT..... | 8 |
| 2.6 | TRIPLE ECCENTRIC DRIVE..... | 8 |
| 2.7 | BEARINGS..... | 9 |
| 2.8 | MOTOR..... | 9 |
| 2.9 | ELECTRONIC BOARDS..... | 10 |
| 3 | INSTALLATION & SET-UP..... | 11 |
| 3.1 | UNPACKING & INSPECTION | 11 |
| 3.2 | VOLTAGE CONFIGURATION | 11 |
| 3.3 | LEVELING..... | 12 |
| 3.4 | INSTALLATION..... | 12 |
| 3.4.1 | <i>Space Requirements</i> | 12 |
| 3.4.2 | <i>Electrical Connections</i> | 13 |
| 3.4.3 | <i>Installation of Platform</i> | 14 |
| 3.4.4 | <i>Flask Clamps Installation</i> | 14 |
| 4 | OPERATION | 17 |
| 4.1 | STARTING THE INNOVA 4300..... | 17 |
| 4.2 | CONTINUOUS (UNLIMITED) RUN | 17 |
| 4.3 | CHECKING A SETPOINT | 18 |
| 4.4 | TIMED FUNCTIONS | 18 |
| 4.4.1 | <i>Setting the Timer</i> | 18 |
| 4.4.2 | <i>Cancelling the Timer</i> | 19 |
| 4.5 | ALARM FUNCTIONS | 19 |
| 4.6 | TEMPERATURE | 19 |
| 4.6.1 | <i>Setting the Temperature</i> | 20 |
| 4.6.2 | <i>Deactivating Temperature Control</i> | 20 |
| 4.7 | TEMPERATURE OFFSET CALIBRATION..... | 21 |
| 4.8 | TOTAL RUNNING TIME | 22 |
| 4.9 | MAINT INDICATOR LIGHT | 22 |
| 4.10 | VENT..... | 22 |
| 5 | MAINTENANCE & SERVICE..... | 23 |
| 5.1 | MAINTENANCE..... | 23 |
| 5.2 | CLEANING | 23 |
| 5.3 | CHANGING FUSES..... | 24 |
| 5.4 | CHANGING VOLTAGE | 24 |
| 5.5 | REPLACING/ADJUSTING THE MOTOR DRIVE BELT | 25 |
| 5.6 | REPLACING THE MOTOR ASSEMBLY..... | 26 |
| 5.7 | ACKNOWLEDGING THE MAINT INDICATOR..... | 27 |

| | | |
|----------|---|-----------|
| 5.8 | RECORDER ADAPTATION | 27 |
| 5.9 | ESD PRECAUTIONS | 28 |
| 5.10 | REPLACING THE MAIN CONTROL BOARD | 29 |
| 5.11 | REPLACING THE TEMPERATURE CONTROL BOARD | 31 |
| 5.12 | QUICK CHANGE PLATFORM OPTION | 32 |
| 5.12.1 | <i>Installing the Quick Change Platform</i> | 32 |
| 5.12.2 | <i>Removing the Quick Change Platform</i> | 33 |
| 5.13 | SERVICE PARTS LIST | 34 |
| 6 | SPECIFICATIONS | 35 |
| 7 | ACCESSORIES | 37 |
| 7.1 | INTERCHANGEABLE PLATFORMS | 37 |
| 7.2 | TEST TUBE RACKS FOR UNIVERSAL PLATFORM | 37 |
| 7.3 | ACCESSORY FLASK CLAMPS | 38 |
| 7.4 | EASY-LOAD PLATFORM OPTION | 38 |
| 7.5 | CLAMP MOUNTING HARDWARE KIT | 38 |
| 8 | DRAWINGS | 41 |
| 8.1 | CONTROL SCHEMATIC | 41 |
| 8.2 | INDEX OF DRAWINGS | 46 |
| 9 | INDEX | 47 |

1 INTRODUCTION

This Manual is intended to provide the user with a complete understanding of how the Innova 4300 Digital Incubator Shaker operates, its basic components, and information about preventative maintenance and service issues. This Manual also includes a complete guide to the installation and operation of the Innova 4300.

The manual is divided into three basic sections. Chapters 1-2 provide an overview of the Innova 4300 and all of its features and options. Chapters 3-4 detail the set-up, installation and operation of the instrument. Chapter 5 outlines troubleshooting and service procedures, which should be utilized only by a qualified service engineer. Chapters 6-9 provide additional details of interest: specifications, lists of accessories, drawings and ordering information. Finally, Chapter 10 is an index to important terms used in the manual.

It is recommended that you completely familiarize yourself with this manual prior to actually operating the Innova 4300.

The Innova 4300 Digital Incubator Shaker will provide you with the reliable and maintenance-free operation which is characteristic of all NBS shakers. The Innova 4300 is among the newest generation of NBS shakers and incorporates a variety of state-of-the-art components and features to permit the precision operation necessary for your exacting scientific experiments.

THIS PAGE INTENTIONALLY BLANK

2 OVERVIEW & FEATURES

2.1 **General Description**

The Innova 4300 shaker incorporates a triple eccentric counterbalanced drive to provide horizontal plane rotary motion in a 1" (25.4 mm) circular orbit. A Proportional/Integral (PI) Microprocessor controller with instantaneous digital feedback controls the speed over a range of 25-500 RPM. It also provides temperature control over a range of 5°C above ambient to 60°C. The internal chamber is 34¾ inches (88.3 cm) wide, 22¼ inches (56.6 cm) deep, 19¼ inches (48.9 cm) above the platform and will accept flasks up to 6 liters. It is equipped with a foot-pedal lid lift.

The shaker may be operated either continuously or in a timed mode via a programmable timer for shaking periods of 0.1 hour to 99.9 hours.

The Innova 4300 is equipped with audible and visible alarms which are activated when an alarm condition exists as follows:

- The end of a timed run
- Deviations of shaking speed or temperature outside of tolerance limits

A wide variety of platforms can be used with the Innova 4300. Dedicated platforms are available for a variety of flask sizes. A Universal platform and test tube racks are available. *(See Chapter 7 for accessories.)*

Additionally, the Innova 4300 has analog outputs for a chart recorder that will record speed and/or temperature. *(See Chapter 5 for recorder adaptation.)*

See Figures 1, 2 and 3 for the front, rear and side views.

Figure 1: Front View

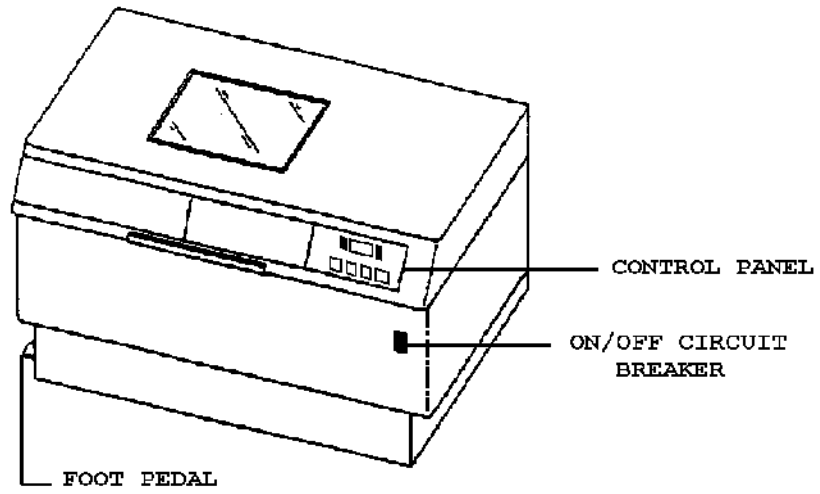

Figure 2: Rear View

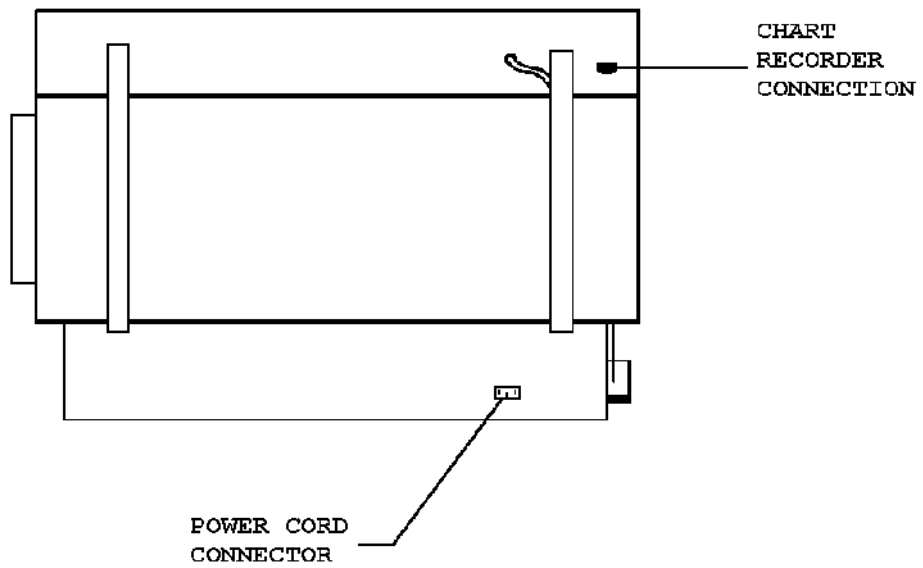
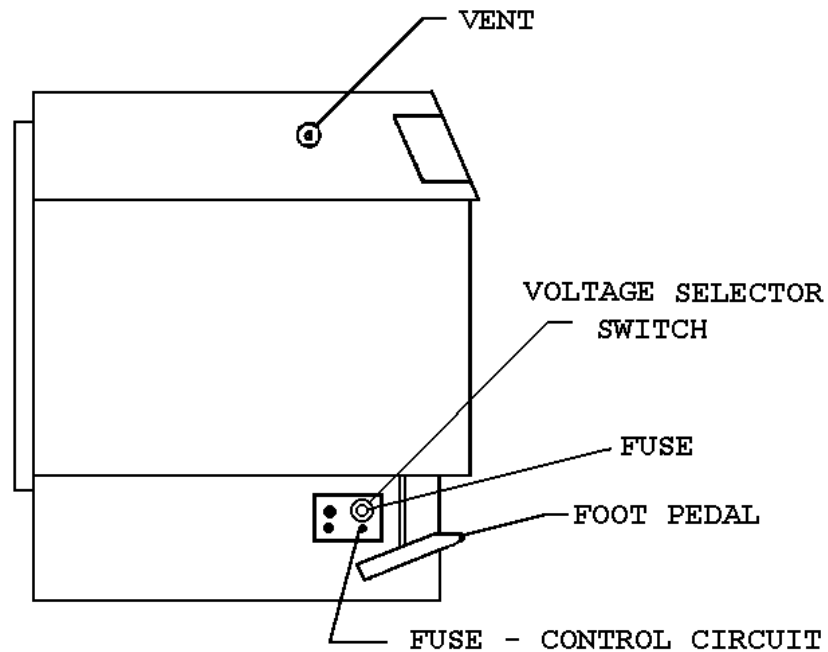

Figure 3: Side View



2.2 *Universal Power Capability*

A voltage selector switch is used to select the appropriate voltage. This universal system adapts to worldwide power requirements. Voltage has been set prior to shipment. Innova shakers are available in 100V, 120V, 220V and 240V and accommodate both 50 and 60 Hz frequencies.



WARNING!

It is critical that you check the voltage setting before you plug the unit into a power source. Make sure the voltage set on the voltage selector switch (see Figure 2) matches the voltage specified on the CAUTION label located over the power cord connection on the rear panel. For details, see Section 3.2.

2.3 Control Panel

The control panel (*see Figure 4 below*) is located on the front of the instrument. It serves as the operator interface. The keypad has four keys marked START/STOP, Δ , ∇ and SELECT. A three-digit LED display provides numeric values as well as some letter codes. There are four **function indicators** and four **status indicator** lights on the control panel as well. A general description of the display, user interface keys and indicators follows.

For operation of the control panel, *see Chapter 4*.

2.3.1 LED Display

The display on the Innova control panel is a 3-digit LED display. During normal shaker operation the display will indicate:

- Shaker status (on/off)
- Shaking speed
- Setpoints
- Hours remaining (timed run)
- Measured temperature
- “Lid” (cover open & shaker operation stops)

2.3.2 User Interface Keys

- **Start/Stop**
This key is used to start or stop the shaking motion. It will also activate or stop the timer when a timed run is desired.
- **Select**
This key is used to change the displayed parameter.
- **Δ , ∇**
These keys are used to adjust the setpoint of a displayed parameter up or down. They also allow the user to enter the SET mode for setpoint changes.

Figure 4: Control Panel

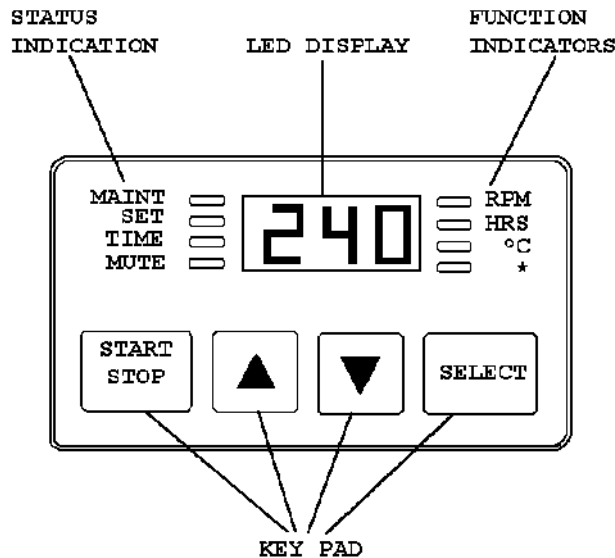

2.3.3 Status Indicator Lights

There are four status indicator lights, located to the left of the LED display:

- **MAINT**
Remains lit after 10,000 hours of use. Accumulated running time is internally monitored and may be displayed as a guideline.
- **SET**
Indicates that the shaker is in the SET mode and setpoints are being displayed and can be altered.
- **TIME**
Indicates that the timer is in operation. Innova shakers can be programmed to run for a preset time from 0.1 hr. to 99.9 hrs. without stopping an ongoing run. The timer can be disengaged or reset.
- **MUTE**
Indicates the status of the audible alarm. When the MUTE indicator is illuminated the audible alarm device is disabled.

2.3.4 Function Indicator Lights

There are four function indicator lights, located to the right of the LED display. They indicate the current parameter being displayed:

- **RPM** Revolutions per Minute
- **Hours** Time Remaining
- **°C:** Temperature

2.4 Platform Assemblies

The Innova 4300 can be used with a wide variety of NBS 18 inch x 30 inch (46 cm x 76 cm) platforms which will accept a variety of clamps for flasks and test tubes (*see Chapter 7 for accessories*).

2.5 Quick-Change Platform Kit

This easy-load accessory enables the user to snap in platforms without tools or hardware. Recommended for speeds up to 400 RPM.

2.6 Triple Eccentric Drive

The Triple Eccentric Drive (*see Figure 5*) used in the Innova Shakers employs the same proven technology which has driven New Brunswick Scientific's shakers for over 30 years.

This drive mechanism utilizes a counterweight system to stabilize the rotary motion produced during operation. When the workload moves in one direction, opposing forces are generated to stabilize the shaker. This action will help eliminate the problem of "walking" which may occur with less precisely balanced instruments. Vibration is minimized and the life of the unit is extended.

Figure 5: Counterbalanced Drive Mechanism

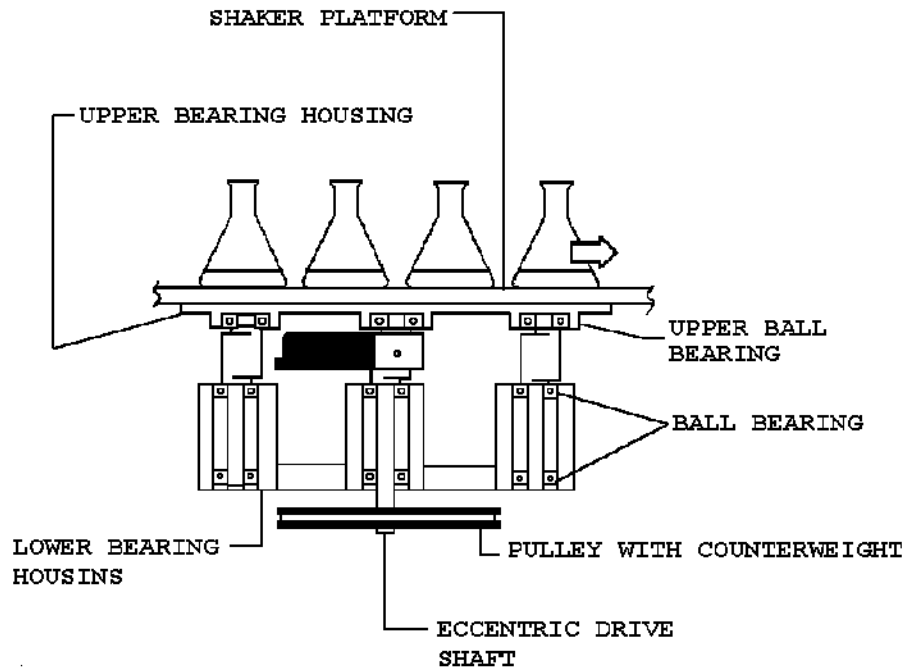

2.7 Bearings

Innova Shakers employ shielded lubricated ball bearings of the highest quality. Shielded bearings minimize the generation of airborne particulates which may be disadvantageous in clean rooms or controlled environment areas. These bearings require no maintenance.

2.8 Motor

The Innova 4300 Shaker uses a 3-phase brushless ball bearing DC motor. This low profile motor provides high torque along with quiet, efficient operation and low maintenance. This motor has a rating of 1/8 horsepower.

2.9 *Electronic Boards*

The main control board for the Innova Shaker has the following functions:

- Non-volatile memory for storage of key parameters during power interruption;
- Speed sensing, electronic commutation and power control for the brushless DC drive motor;
- Maintains an elapsed running time clock;
- Contains firmware for shaker control as well as recognition of an expansion connector for option modules;
- Provides an operator interface via displays, audible alarm, and connection to the keypad module (keypad buttons and display graphics).

Its Temperature Control module has the following functions:

- Control of analog power supplies;
- Rectification and regulation for analog power supplies;
- Provides signal conditioning circuitry and A/D conversion for the RTD-based temperature measurement;
- Provides remote monitoring capabilities by supplying analog output for speed and temperature which are compatible with chart recorders and analog data acquisition system;
- Controls the heater.

3 INSTALLATION & SET-UP

The Innova 4300 is a versatile instrument which can be operated in a continuous fashion or set for a timed run. The following section describes set-up and installation procedures.

3.1 Unpacking & Inspection

Upon unpacking the unit, inspect it carefully for any apparent damage which may have occurred during transit. Report any damage to the carrier and to the New Brunswick Scientific Co., Inc. Service Department (in the USA, call 1-800-631-5417) or to your NBS Service Representative. **Do not discard the crate or packing material.**

3.2 Voltage Configuration



WARNING!

It is critical that you check the voltage setting before you plug the unit into a power source.

Confirm that the Voltage setting is correct by checking the Voltage Selector on the side (see Figure 3) and the CAUTION label located over the power cord connection on the rear panel.

In addition to checking the voltage of your unit as indicated in the WARNING above, be sure to confirm that the correct electrical service package is included with the unit. Compare the part number on the electrical service package to the following table:

| VOLTAGE CONFIGURATION TABLE | | |
|-------------------------------------|-----------------------|--|
| <i>Innova 4300 Catalog #</i> | <i>Voltage</i> | <i>Electrical Service Package</i> |
| M1193-0001 | 100V 50/60Hz | M1193-0071 |
| M1193-0000 | 120V 50/60Hz | M1193-0071 |
| M1193-0002 | 220V 50/60Hz | M1193-0070 |
| M1193-0003 | 240V 50/60Hz | M1193-0070 |

3.3 *Leveling*

The Innova 4300 should be installed on an even surface. The eight feet can be adjusted for leveling when necessary. Adjustment can be made by loosening the locking nuts on the threaded studs attached to the feet, then retightening when the level condition is attained.



NOTE:

Use of the Innova Shakers requires a platform, which is a separate item. Available platforms are listed in Chapter 7.

3.4 *Installation*

3.4.1 **Space Requirements**

It is essential that the instrument be situated in an area where there is sufficient space for the shaker and service lines (*see Figure 6*).

The outside dimensions of the Innova 4300 are:

| | Inches | Centimeters |
|---------------|---------------|--------------------|
| Width | 43 | 109 |
| Depth | 28 | 71 |
| Height | 37 | 94 |

The effective surface area required for operation is:

| | Inches | Centimeters |
|--------------|---------------|--------------------|
| Width | 46 | 117 |
| Depth | 30 | 76 |

Figure 6: Space Requirements

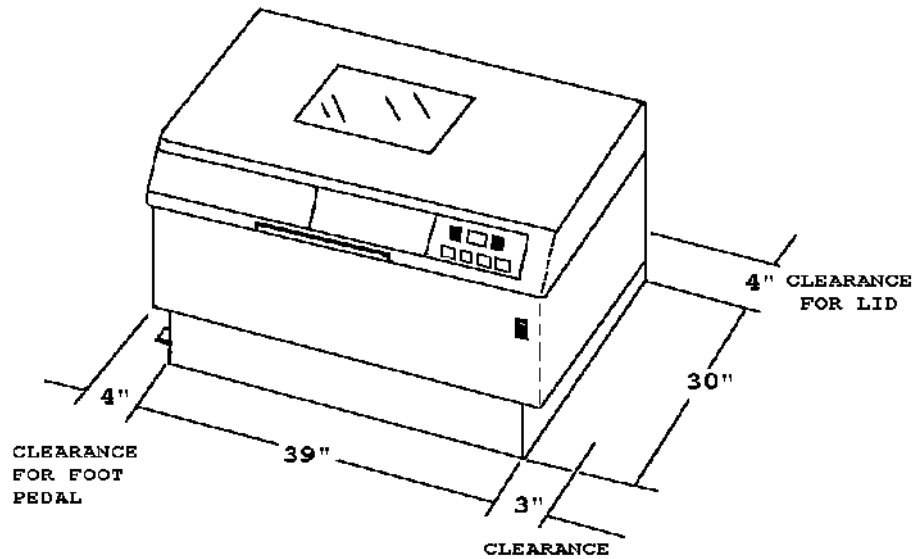

3.4.2

Electrical Connections

**CAUTION!**

Be sure to check the following items **BEFORE** making electrical connections.

1. Check the voltage selector switch on the side of the unit (*see Figure 3*) against the Caution label on the rear of the unit, to ensure that it is set to the appropriate voltage.
2. Remove the caution label from the rear of the unit.
3. Set the circuit breaker on the front of the unit to the OFF position.

**CAUTION!**

A grounded electrical outlet is necessary for the safe operation of this unit.

4. Connect the power cord to the power cord connection and then to a grounded electrical outlet.

3.4.3 Installation of Platform

A platform must be installed on the unit prior to use. To install the platform:

1. Set the power switch in the off position. Open the cover.
2. The unit is shipped with the four platform screws installed in the subplatform of the bearing housing. These screws must be removed before a platform can be installed. Using the 7/32 inch hex wrench provided, loosen and remove the platform screws from the bearing housing. Retain the screws for reuse.
3. Place the platform on the on the subplatform of the bearing housing.
4. Reinstall and secure the four Allen head platform screws, with the 7/32 inch hex wrench provided, to secure the platform.

If the Quick Change Option is installed:

1. Slip the platform between the side guides and push the platform to the rear retainer.
2. Press down on the front edge of the platform. The platform should snap down into place and be retained by the springs. Check that the rear edge of the platform is engaged under the bend of the rear clip.



NOTE:

The recommended maximum speed with a Quick Change platform is 400 RPM.

3.4.4 Flask Clamps Installation

Flask clamps purchased for use with universal platforms require installation. Clamps are installed by securing the base of the clamp to the platform with the correct type and number of screws (refer to clamp hardware application charts provided below).

All clamps are shipped complete with hardware. Clamps for 2- to 6-liter flasks are shipped with an additional girdle to keep the flasks in place. To install 2- to 6-liter clamps:

1. Place clamp on platform, secure in place with correct type of screws (refer to clamp hardware application charts below).

2. Place the loose girdle around the upper portion of clamp body so that it is held in place by the legs of the clamp.
3. Insert the flask into the clamp.



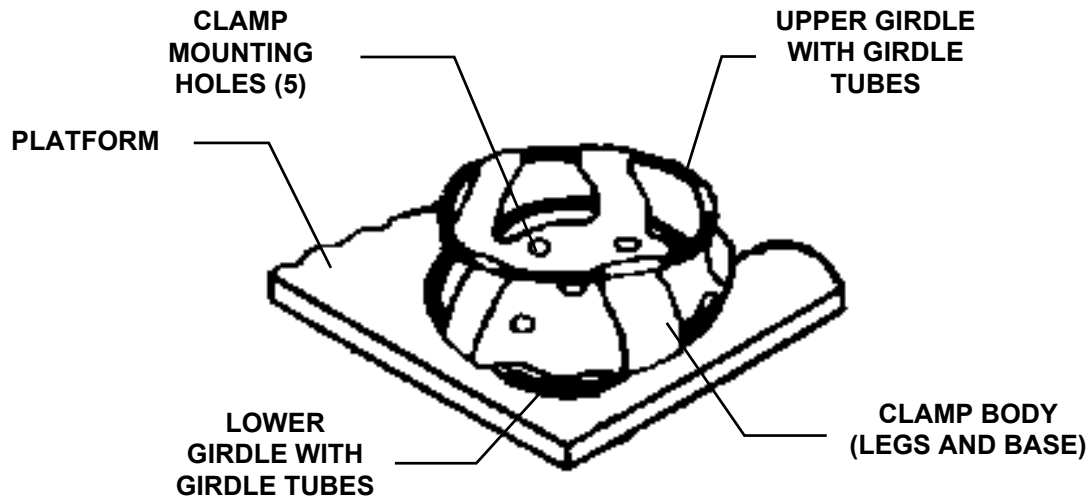



Figure 7: 2- to 6-Liter Flask Clamp Installation









 **NOTE:** 2800 ml Fernbach Flask Clamp applicable to above.

NBS flask clamps are used on a variety of shaker platforms. Flat head screws of different lengths and thread pitch are used to secure the clamp. The following tables identify the proper screw for your shaker application by reference to the head style.

10 to 500 ml Clamp Hardware Application Chart

| <i>Description</i> | <i>Part Number</i> | <i>Qty.</i> | <i>Application</i> |
|---|--------------------|-------------|--|
|  10-24 x 5/8 (15.87 mm) flat Phillips (+) head screw | S2116-3101 | 1 | 3/4" (19.05 mm) thick wood platform  |
|  10-24 x 5/16 (7.9 mm) flat Phillips (+) head screw | S2116-3051 | 1 | 5/16" (7.9 mm) thick aluminum, phenolic and stainless steel platforms.  |
|  10-32 x 5/16 (7.9 mm) flat slotted (-) head screw | S2117-3050 | 1 | all stainless steel platforms  |

1- to 6-Liter Clamp Hardware Application Chart

| | <i>Description</i> | <i>Part Number</i> | <i>Qty.</i> | <i>Application</i> |
|---|---|--------------------|-------------|--|
|  | 10-24 x 5/8 (15.87 mm) flat Phillips (+) head screw | S2116-3101 | 5 | 3/4" (19.05 mm) thick wood platform  |
|  | 10-24 x 5/16 (7.9 mm) flat Phillips (+) head screw | S2116-3051 | 5 | 5/16" (7.9 mm) thick aluminum, phenolic and stainless steel platforms.   |
|  | 10-32 x 5/16 (7.9 mm) flat slotted (-) head screw | S2117-3050 | 5 | all stainless steel platforms  |



NOTE: 2800 ml Fernbach Flask Clamp applicable to above chart.

4 OPERATION

4.1 *Starting the Innova 4300*

To initially start the instrument, push the ON/OFF switch on the right side of the shaker to the ON position.



NOTE:

The LED display will flash to indicate that the shaker has been off or the power to the shaker has been interrupted. To stop the flashing display, press any key.

Press the **SELECT** key until the RPM indicator lights. If the shaker is running, the LED display will track the speed as it accelerates to the last entered setpoint.

The shaking action may be stopped or started by pressing the **START/STOP** key.

The shaker motor stops when the cover is opened. While the cover is open and the display mode is RPM, the display will read “Lid”.

At the higher speed ranges, it is recommended that the platforms have a 30% minimum load to maintain a good balance condition.

4.2 *Continuous (Unlimited) Run*

To set up a continuous run:

1. If the LED displays “Off”, press the **START/STOP** key.
2. Press **SELECT** until RPM is lit.
3. Press either Δ or ∇ to enter SET mode (set indicator will light).
4. Set the speed by using the Δ or ∇ key until the desired setpoint is displayed.



NOTE:

Holding the Δ or ∇ key down will cause the setting to change more rapidly.

The setpoint may be changed during a run without stopping the shaker by following steps 2-4 above. During speed changes, the alarm will flash until the speed returns to within 5 RPM of the setpoint; do not be concerned.

4.3 **Checking a Setpoint**

To check any setpoint:

1. Press **SELECT** until the desired indicator is lit.
2. Press either Δ or ∇ to enter the SET mode, which will display the current setpoint.



NOTE:

Holding the Δ or ∇ key for more than 0.5 second causes the speed, time or temperature setpoint to change. Should this occur, resetting will be necessary.

4.4 **Timed Functions**

The shaker may be programmed to automatically stop after a preset time period of 0.1 hour to 99.9 hours. There must be power to the shaker in order to set the timer. However, a timed run can be initiated while the unit is either shaking or stopped.

4.4.1 **Setting the Timer**

To set the timer:

1. Press the **SELECT** key to light HRS.
2. Set the time by pressing Δ or ∇ key until the desired setpoint is displayed (0.1 to 99.9 hours).
3. To start the timer operation, press the Δ or ∇ key once. The SET indicator should light. While the SET indicator is on, press the **START/STOP** key. The time indicator will light and remain lit for the duration of the run. At the end of the timed run, the display will read "Off", the time indicator will flash, and the audible alarm will sound (if it is enabled).
4. The setpoint may be changed during a run without stopping the shaker by following steps 1 and 2.

5. To stop the alarm, press the **SELECT** key and change to any other function.

4.4.2 Cancelling the Timer

To cancel the timer WITHOUT stopping the shaker:

1. Press the **SELECT** key to light HRS.
2. Set the time by pressing the Δ or ∇ key until the desired setpoint is displayed (0.1 to 99.9 hours).
3. While the SET LED is lit, press the **START/STOP** key. The TIME indicator will go out and the display will read "Off".

4.5 Alarm Functions

Innova 4300 has an audible alarm which is activated at predetermined times. It may be deactivated in the following way:

1. Press **SELECT** to light HRS.
2. **Simultaneously** press the Δ and ∇ keys. The SET and MAINT indicators will flash.
3. While the SET and MAINT indicators are flashing, press the **START/STOP** key. The MUTE indicator will light to advise that the audible alarm is deactivated.

To reactivate the alarm, repeat steps 1-3. The MUTE indicator will be extinguished when the alarm has been reactivated.

4.6 Temperature

This control consists of an internal electrical interface, an RTD temperature probe, and an analog output for chart recorder or computer. The temperature can be set from 5.0°C above ambient to 60.0°C.

4.6.1 Setting the Temperature

To set the temperature setpoint:

1. Press the **SELECT** key until the function indicator lights on the °C mode.
2. Increase or decrease the setpoint by pressing the Δ or ∇ key (5.0°C above ambient is the minimum possible setpoint).

The temperature alarms, both audible and flashing light, are activated if the temperature is more than 1.0°C higher or lower than the temperature setpoint. The alarm will automatically deactivate as the unit achieves the set temperature.

4.6.2 Deactivating Temperature Control

If desired, the temperature control system may be shut off during set-up for special investigations.

To deactivate the temperature control system:

1. Press and hold the ∇ key until the setpoint is at 4.0°C.
2. While holding the ∇ key, simultaneously press the **START/STOP** key. The temperature setpoint display shows “Off” and both the heater and the refrigeration system will be deactivated.

To re-activate the temperature controller:

1. Press the Δ key until the desired temperature setpoint is displayed.



NOTE:

The shaker may be started or stopped by pressing the START/STOP key. When starting, the unit will automatically return to the last function and setting. The alarms will be activated until the speed is within 5 RPM or the temperature is within 1.0°C of the setpoint. The alarm will not sound when the shaker is accelerating or the temperature is changing to satisfy a new setpoint.

4.7 Temperature Offset Calibration

The temperature probe and the temperature controller are calibrated together at the factory. The temperature probe measures the temperature of the air at the probe's location, near the heat exchanger return vent. The controller uses the probe input to adjust air temperature, up or down, to match the temperature setpoint.

Depending on various conditions within the chamber, such as flask placement and size, the heat produced by growing organisms, heat losses due to liquid evaporation from flasks, etc., the display temperature may differ from temperatures within the flasks themselves.

If you wish to have the temperature display ("Indicated Temperature") match the temperature at a given point, or match the average of a series of points within the chamber ("Actual Temperature"), proceed as follows:

1. Let the unit equilibrate at or near the desired temperature. Record the Indicated Temperature.
2. Record the Actual Temperature.
3. Calculate the temperature correction value: Actual Temperature – Indicated Temperature = Temperature Correction Value.
4. Press the **SELECT** key until the °C function indicator illuminates.
5. **Simultaneously** press the Δ and ∇ keys. The SET and MAINT indicators will light.
6. While the SET and MAINT indicators are illuminated, use the Δ or ∇ key to set the display to the calculated Temperature Correction Value.



NOTE:

The °C light will pulse rapidly for a short duration to indicate it is not operating in the factory default mode. It will pulse for a longer duration and less rapidly (with a frequency of approximately one second) to indicate temperature is more than one degree above or below setpoint.

To return to the factory calibration:

1. Press the **SELECT** key until the °C function indicator illuminates.
2. Simultaneously press the Δ and ∇ keys. The SET and MAINT indicators will light.

3. While the SET and MAINT indicators are illuminated, press the START/STOP key.

4.8 Total Running Time

The control module of the Innova 4300 totals the time the shaker has been “ON” to track hours of usage.

To display the accumulated running time:

1. Select HRS using the **SELECT** key.
2. **Simultaneously** press the Δ and ∇ keys.

The SET and MAINT indicators will flash and the accumulated running time will be displayed in hundreds of hours (i.e., “02” equals 200 hours; “102” equals 10,200 hours). This display will continue for 10 seconds and then default to the previous mode readout.

4.9 MAINT Indicator Light

After 10,000 hours of operation, the MAINT indicator will light. Preventive maintenance is recommended at this point. The light can be deactivated by NBS Service Personnel. Alteration of the internal clock by unauthorized personnel will void the warranty.

4.10 Vent

The Innova 4300 is provided with a vent to exhaust gas or allow small amounts of ambient air into the chamber. The vent is located in the left side of the cabinet (*see Figure 3*).

When the knob is tight (in a clockwise position), the vent holes are sealed. Rotate the knob counter-clockwise to open the vent.

5 MAINTENANCE & SERVICE

The following section describes basic cleaning and maintenance instructions for the user.

*There are also troubleshooting and service procedures, and instructions to install optional features. **These must be performed by a qualified service engineer.***



WARNING!

Before cleaning the instrument, and before a qualified Service Engineer performs any maintenance or service procedures, be sure to turn the power off (using the ON/OFF switch on the shaker's front right-hand panel). Also disconnect the power cord.

5.1 Maintenance

The Innova Shaker requires no routine mechanical maintenance on the part of the user. The MAINT indicator light goes on 10,000 hours after the unit was last serviced. At that time contact your local NBS Service Engineer or call the NBS Service Department at 1-800-631-5417 (from the United States). This periodic maintenance will keep your unit in premium condition.

5.2 Cleaning

The outside painted surfaces can normally be cleaned with a damp cloth and, if necessary, standard household or laboratory cleaners. **Do not use any abrasive or corrosive compounds to clean this instrument**, as they may damage the unit and void the warranty.

The viewing window is glass and can be cleaned with any household or laboratory glass cleaner or polish.

**WARNING!**

None of the following procedures should be attempted by anyone who is not a qualified Service Engineer or Technician.

5.3 Changing Fuses

The unit is designed with a circuit breaker, which is used as an **ON/OFF** switch. There are two fuses on the left side of the unit (*see Figure 3*). One is to protect the control circuitry and the other is to protect the motor circuit. The motor circuit fuse is mounted in the center of the voltage selector switch.

To remove either fuse:

1. Insert a small, flat-bladed screwdriver and turn counter-clockwise until it disengages and the fuse holder springs free.
2. Check the fuse. If it has failed, replace it with a like fuse as identified in the Spare Parts List (see Section 5.13). Spare fuses are supplied with the unit.

5.4 Changing Voltage

Innova 4300 is set to the appropriate line voltage prior to shipment. The voltage selector switch (*see Figure 3*), however, is a universal power-entry device which can be reset to adapt to worldwide power requirements.

If it becomes necessary to set to a different voltage:

1. Set the **ON/OFF** switch (*see Figure 1*) to OFF.
2. Disconnect the unit from the power source.
3. Using a small, flat-bladed screwdriver, rotate the center portion of the switch until the fuse is disengaged. Remove the fuse.
4. Using a larger flat-bladed screwdriver or a small coin, rotate the center portion of the switch to the desired voltage. The indicator is at the top of the switch.
5. Replace the fuse and holder.
6. Check that the proper power cord is available for the voltage selected.

7. Plug the power cord into the power cord connection on the unit and the power source.
8. Set the **ON/OFF** switch to the ON position.

The unit is ready for operation.

5.5 Replacing/Adjusting the Motor Drive Belt

To replace or adjust the motor drive belt:

1. Turn off the power and remove the power cord.
2. Remove the lower front cover using a Phillips (+) screwdriver.
3. Rotate the large pulley and exert a light pressure to the belt so the belt feeds out of the pulley groove (*see Figure 8*).

Figure 8: Belt Replacement & Adjustment

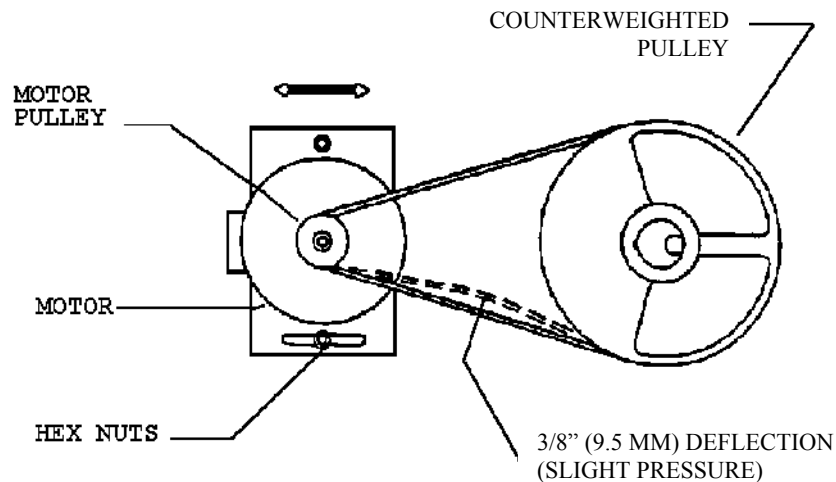

4. Install a new belt by feeding onto the motor pulley and guiding onto the motor pulley and guiding onto the large pulley while rotating the small pulley.



CAUTION!

Be sure to keep fingers clear to avoid pinching them between the belt and pulley.

5. Check the belt tension with a light side pressure near the center of the belt. It should deflect approximately 3/8 inch (9.5 mm).
6. If adjustment is needed, loosen the two nuts holding the motor plate and move the plate to either loosen or tighten the belt. Tighten the nuts when the adjustment is correct.
7. Replace the lower front cover.
8. Connect the power cord.
9. Set the circuit breaker to the “ON” position.

The unit is ready for operation.

5.6 Replacing the Motor Assembly

1. Turn off the power and disconnect the power cord.
2. Remove the lower front cover using a Phillips (+) screwdriver.
3. Remove the connector from the motor assembly (*see Figure 9 below*). Remove the green ground wire going to the chassis (disconnect from the chassis side).

Figure 9: Motor Assembly Replacement

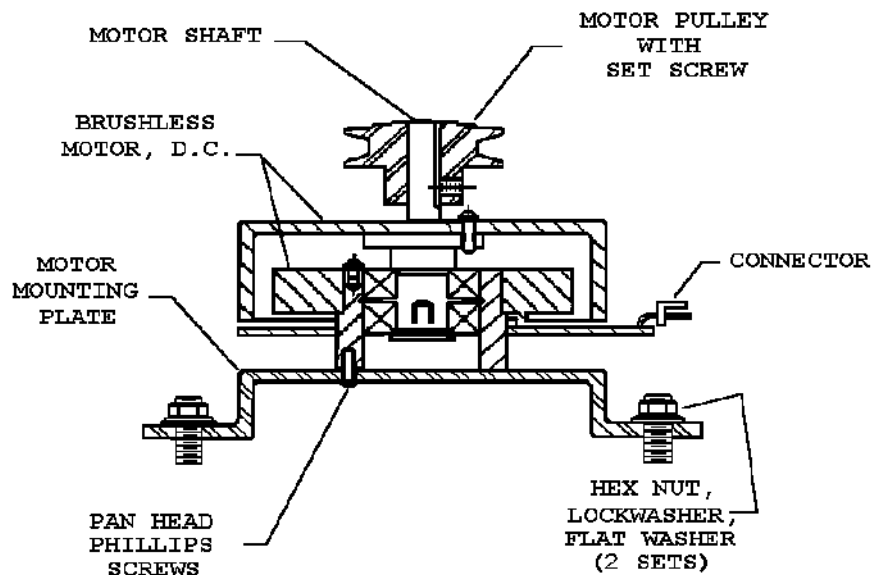

4. Remove the 2 hex nuts and washers and lift out the motor and plate assembly.
5. Position the new motor assembly back onto the unit. Replace the 2 hex nuts with their associated hardware. Do not tighten.
6. Connect the green wire coming from the motor assembly to the chassis. Replace the belt. Adjust the motor pulley height so that the belt is level as related to the drive pulley. Tighten the set screw.
7. Adjust the belt tension as shown in Figure 8. Tighten the 2 hex nuts.
8. Rotate the large pulley by hand and see that the belt tracks smoothly.
9. Replace the motor connector. Be sure the motor connector is positioned with no pins visible. Reconnect the green wire from the motor assembly to the chassis.
10. Replace the lower front cover.
11. Connect the power cord and turn the circuit breaker to the ON position.

The unit is ready for operation.

5.7 *Acknowledging the MAINT Indicator*

After the shaker has been operating for 10,000 hours accumulated running time (initially, or since the previous maintenance check), the MAINT indicator light on the control panel will light. Only an NBS Service Engineer can turn it off.

The MAINT light indicates that it is time for a routine maintenance check. A regular schedule of routine maintenance is an excellent way to keep your valuable equipment performing optimally for years of reliable service.

5.8 *Recorder Adaptation*

To record speed and temperature, a recorder (not supplied) can be used. It should have the following capabilities:

- To record both speed and temperature, two channels are required. Each channel should have signal conditioning which accepts 0-5 volt input. The pin-out diagram and scale below identify the application.
- A mating connector is required on the recorder cable (not supplied). This is a 9-pin male D subminiature connector, AMP Amplimite HDP-20 series or equivalent.

Figure 10: Recorder Connector

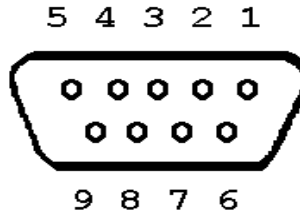

 **NOTE:**

The figure above is the pin-out diagram, as seen from the rear of the unit. The chart below identifies the pin application and scale.

| Pin No. | Signal Name | Scale |
|---------|-------------|--------------|
| 6 | Speed | 1V = 100 rpm |
| 2 | Ground | |
| 7 | Temperature | 1V = 20° C |
| 3 | Ground | |



WARNING!

Do not attempt to change boards or electronic components unless you are a qualified Service Engineer or Technician.

Integrated circuits are extremely susceptible to damage from electrostatic discharge. The Service Engineer or Technician should read and follow the ESD Precautions below before undertaking any work.

5.9 ESD Precautions

1. Do not remove components from their antistatic packaging until you are ready to insert them into their sockets or install the board.
2. Before handling components or boards, touch an unpainted portion of the system unit chassis for a few seconds.
3. Wear a wrist grounding strap, available from most electronic component stores.

5.10 Replacing the Main Control Board

1. Switch the shaker off and disconnect the line cord.
2. Open the lid and remove the (2) 3/8 inch hex nuts. These nuts are located on the back of the front panel.
3. Carefully push the two threaded studs, now exposed, so that the control panel eases out from the lid.

Figure 11: Control Board Replacement

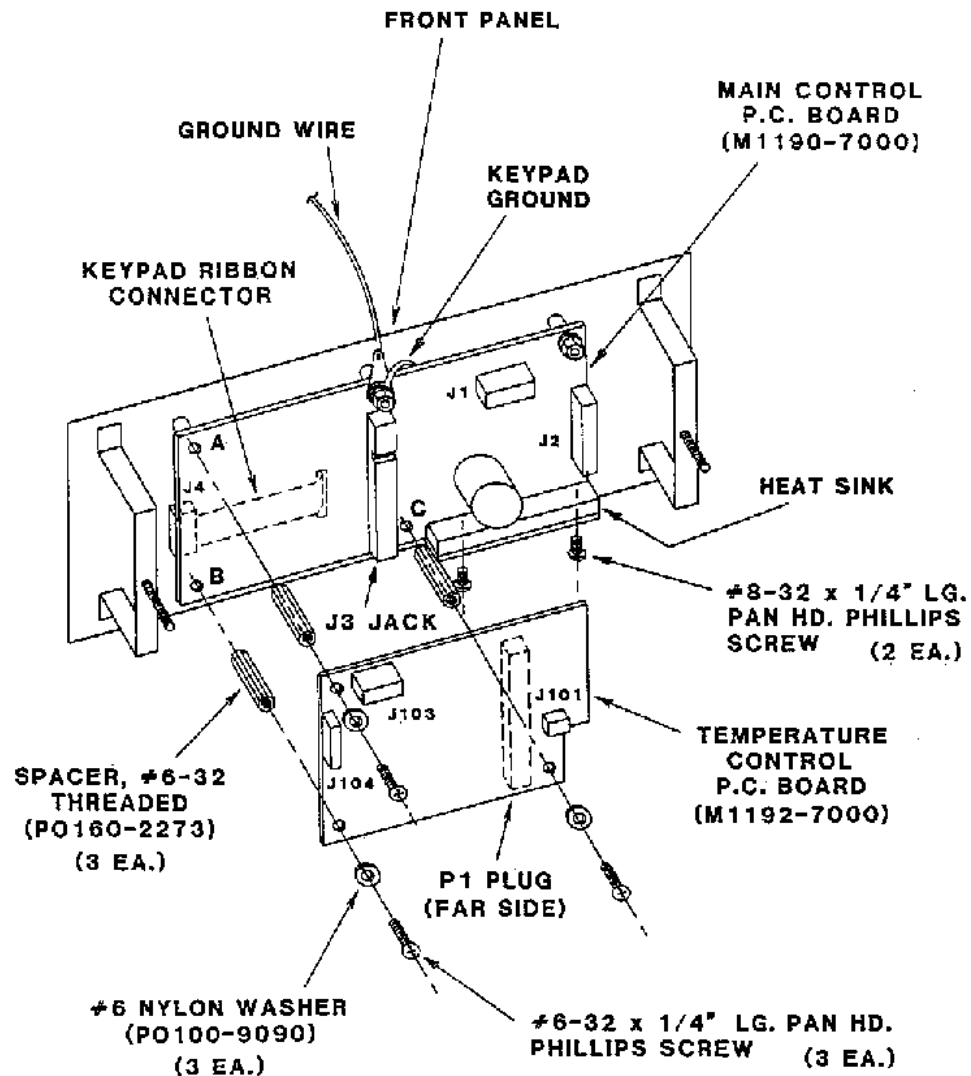

4. Disconnect the harness wiring from connectors J1, J2, J101, J102, J103 and J104 (see Figure 11 above).

5. Remove the temperature control board:
 - a. Remove the three $\frac{1}{4}$ inch screws and nylon flat washers.
 - b. Disconnect the temperature control board from the main control board, being careful not to damage the board-to-board connectors. Apply force perpendicular to the plane of the board. **Do not lift from one end.**
6. Remove the three hex spacers and two $\frac{5}{16}$ inch hex nuts.
7. Remove the green wire and keyboard ground lead.
8. Remove the two screws that fasten the heat sink to the front panel bracket.
9. Lift the board out of the bracket assembly and disconnect the keypad connector from J4.

**NOTE:**

Be careful not to lose the five $\frac{1}{4}$ " spacers or the gray insulator.

10. Position the gray insulator on the solder side of the new main control board and connect the keypad connector to J4.
11. Make sure the five $\frac{1}{4}$ inch spacers are in place on the mounting studs and mount the new main control board.
12. Replace the two screws that fasten the heat sink to the bracket assembly. Do not tighten at this time.
13. Replace the three hex spacers and tighten.
14. Replace the keypad ground lead and the green wire from the main chassis.
15. Replace the two $\frac{5}{16}$ inch hex nuts and tighten.
16. Tighten the two heat sink mounting screws.
17. Reconnect the harness wiring to connectors J1 and J2. Make sure that each connector is properly positioned (keys mate and no pins remain exposed).
18. Replace the temperature control board:
 - a. Snap the new temperature control board onto the main control board, making sure the board-to-board connectors mate properly.
 - b. Replace the three nylon flat washers and $\frac{1}{4}$ inch screws.

- c. Reconnect the harness wiring to connectors J101, J102, J103 and J104. Make sure that each connector is properly positioned (keys mate and no pins remain exposed).
 - d. Replace the panel and secure with the two 3/8 inch hex nuts.
19. Replace the panel and secure with the two 3/8 inch hex nuts.
 20. Connect the line cord to the rear of the shaker.

5.11 Replacing the Temperature Control Board

1. Switch the shaker OFF and disconnect the line cord from the rear of the shaker.
2. Open the lid and remove the two 3/8 inch hex nuts. These nuts are located on the back of the front panel.
3. Carefully push the two threaded studs, now exposed, so that the control panel eases out from the lid.
4. Disconnect the harness wiring from connectors J101, J102, J103 and J104 (*see Figure 11 above*).
5. Remove the three 1/4 inch screws and nylon flat washers.
6. Disconnect the temperature control board from the main control board, being careful not to damage the board-to-board connectors. Apply force perpendicular to the plane of the board. **Do not lift from one end.**
7. Snap the new temperature control board onto the main control board, making sure the board-to-board connectors mate properly.
8. Replace the three nylon flat washers and 1/4 inch screws.
9. Reconnect the harness wiring to connectors J101, J102, J103 and J104. Make sure that each connector is properly positioned (keys mate and no pins remain exposed).
10. Replace the panel and secure with the two 3/8 inch hex nuts.
11. Connect the line cord to the rear of the shaker.

5.12 Quick Change Platform Option

The Easy Loading Platform Kit enables user to change or mount the series of 18 inch x 30 inch (46 cm x 76 cm) platforms, using no tools or hardware.

The following parts are required to make this upgrade or change; they are included in the kit:

| Qty | Description (M1193-9931 Kit) |
|------------|--|
| 1 | Plastic subplatform with springs, retainers & friction pads attached |
| 1 | Counterweight with tapped holes |
| 1 | Counterweight with clearance holes |
| 2 | ¼-20 x 2-inch long pan head Phillips (+) screws and lock washers |
| 4 | 3/8-16 x 1-inch long Allen socket flat head screws |
| 1 | 7/32 inch Allen key wrench |

5.12.1 Installing the Quick Change Platform

1. Turn the power off using the power switch and disconnect the line cord.
2. Check the parts in the kit, to be sure you have everything you need.
3. Remove the existing platform, if one is on the machine.
4. Rotate the counterweight so that the heavy section is in the extreme right position.
5. Slip the set of counterweights under the unit counterweight, keeping the part with the clearance holes on top and the one with the tapped holes below. Mount with the two ¼ inch x 2 inch long screws and lock washers supplied (*see Figure 12 below*). Be sure to tighten the screws securely.
6. Mount the subplatform with the four flat head Allen screws, taking care to keep the side with the two springs toward the front of the machine. Tighten the screws securely.
7. Slip an 18 inch x 30 inch (46 cm x 76 cm) platform between the side guides, push the platform to the rear retainer and press down on the front edge of the platform. It should snap down into place and be retained by the springs. Check that the rear edge of the platform is engaged under the bend of the rear retainer.
8. Plug in the power cord, switch on the power, and the unit is ready for operation.

Figure 12: Quick Change Platform Option

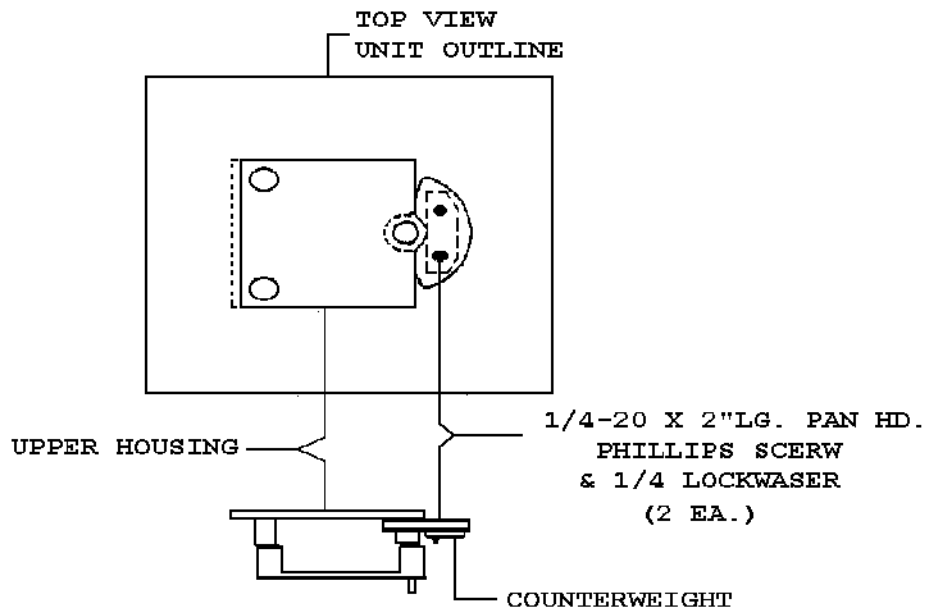

5.12.2 Removing the Quick Change Platform

To remove the Quick Change Platform:

1. Stop the machine by pressing the **START/STOP** key.
2. Face the machine squarely.
3. Put your index fingers under each front corner of the platform. Note that there is a relief in these corners on the subplatform. With your thumbs, press the two corner springs toward your body, and with an upward pressure with index fingers, lift the platform from its retained position.



NOTE:

We recommend that the maximum speed not exceed 400 RPM when you are using the Quick Change Platform.

5.13 Service Parts List

| NBS Part Number | Description | Quantity |
|------------------------|-----------------------------|-----------------|
| P0380-3710 | 0.16A Fuse (Low Voltage) | 1 |
| P0380-3532 | 1.6A Fuse (Selector Switch) | 1 |
| P0420-1610 | 10 VA Transformer | 1 |
| M1191-5300 | 130 VA Transformer | 1 |
| P0320-0350 | 21000 uF Capacitor | 1 |
| P0460-4091 | Diode Bridge | 1 |
| P0360-4040 | 130V Varistor | 2 |
| M1191-4000 | Large Motor Assembly | 1 |
| M1190-9941 | Main Control Board | 1 |
| M1192-7000 | Temperature Control Board | 1 |
| M1190-5000 | Membrane Sw. Panel | 1 |
| P0400-0980 | Voltage Selector Switch | 1 |
| P0400-4330 | 10A Circuit Breaker | 1 |
| P0400-3011 | 10A Solid State Relay | 1 |
| P0400-2751 | Relay | 1 |
| P0620-1380 | 250 Watt Heater | 2 |
| M1195-8001 | RTD Assembly | 1 |
| P0720-2024 | Power Cord 120V 15A | 1 |
| P0720-2021 | Power Cord 220V | 1 |
| B-162 | Bearing, Upper Housing | 3 |
| P0180-0282 | Bearing, Shielded | 6 |
| R-337 | Belt | 1 |
| M1193-6331 | Bearing Housing Assembly | 1 |
| M1193-9901 | Lid Gasket | 1 |
| P0400-1531 | Magnetic Switch | 1 |
| P0400-1538 | Magnet | 1 |
| P0620-2561 | 6" Fan | 1 |
| M1193-9902 | Glass Window | 1 |
| P0640-0380 | Gas Springs | 2 |

6 SPECIFICATIONS

This chapter provides technical details of interest, but not necessarily essential for operation of the instrument.

| | |
|--|---|
| SHAKING | |
| Speed | 25-500 RPM |
| Motion | 1 inch (25.4 mm) diameter circular orbit |
| Indication | LED digital electric display, 1 RPM increments |
| Setpoint & Control | Digital adjustment with PI microprocessor control and instantaneous visual feedback |
| Accuracy | ± 1 RPM |
| DRIVE | |
| Triple eccentric counterbalanced ball bearing drive. | |
| TEMPERATURE | |
| Range | 5.0°C above ambient to 60°C |
| Control Stability | $\pm 0.1^\circ\text{C}$ by use of PI microprocessor controller and pulse width modulation of heater |
| Setpoint | Digital adjustment increments within 0.1°C instantaneous visual feedback |
| Accuracy | $\pm 0.1^\circ$ @ 30-40°C range $\pm 0.25^\circ\text{C}$ for remaining range |
| Uniformity | Better than $\pm 0.25^\circ\text{C}$ over entire range |
| Safety | Heater shuts off if temperature exceeds operating range |
| Heater | Low watt density resistance heater with high temperature safety thermostat |
| TIMER (Shaker) | |
| <ul style="list-style-type: none"> • Programmable shaking periods from 0.1 hour to 99.9 hours by a digital timer that shuts off at the end of period and energizes status light. • Timer counts down and digital display indicates remaining time. Can be deactivated for continuous operation. • Additionally, unit will display total accumulated running time for service information. | |
| AMBIENT OPERATING ENVIRONMENT | |
| 0° - 40°C, 90% humidity, non-condensing | |
| SELF-DIAGNOSTIC STATUS | |
| Warning signal (audible and visible) indicates when shaking speed deviates more than 5 RPM or the temperature deviates more than 1.0°C from setpoint and when timer operation has expired. The audible alarm can be deactivated/activated by the operator. | |
| REMOTE MONITORING | |
| <ul style="list-style-type: none"> • Chart recorder outputs for speed and temperature (0-5V). • 1V per 100 RPM; 1V per 20°C, accuracy $\pm 25\text{mV}$. | |

| AUTOMATIC RESTART | | |
|--|---------------------------------------|-----------------|
| <ul style="list-style-type: none"> • Unit will automatically restart after undesired power interruption. • Setpoints are maintained by non-volatile memory. • Interruption is indicated by a flashing display. | | |
| AUTOMATIC DRIVE | | |
| Interrupt when lid is opened. | | |
| MOTOR | | |
| 1/8 HP, 3-phase brushless ball bearing DC motor. | | |
| ELECTRICAL SERVICE | | |
| <ul style="list-style-type: none"> • 100V, 120V, 220V, 240V • 50 or 60 Hz • 700 VA Universal power entry system adapts to U.S. or International requirements. | | |
| DIMENSIONS | | |
| Width | 43 inches | 109 cm |
| Depth | 28 inches | 71 cm |
| Height | 37 inches | 94 cm |
| PLATFORM DIMENSIONS | | |
| | 18 inches x 30 inches | 46 cm x 74.6 cm |
| CHAMBER DIMENSIONS (Interior) | | |
| Width | 34 ³ / ₄ inches | 88.3 cm |
| Depth | 22 ¹ / ₄ inches | 56.6 cm |
| Clearance (above platform) | 19 ¹ / ₄ inches | 48.9 cm |
| CONSTRUCTION | | |
| <ul style="list-style-type: none"> • Heavy gauge steel, phosphate-coated and texture-painted cabinet. • 17-inch hermetically sealed double-pane viewing window for complete chamber visibility. • Stainless steel chamber (interior). | | |
| WEIGHT | | |
| Net | 398 lbs | 181 kg |
| Gross | 490 lbs | 223 kg |

7 ACCESSORIES

7.1 *Interchangeable Platforms*

Following are 18 inch x 30 inch (46 cm x 76 cm) platforms:

| Catalog No. | Clamps/holders | Size of Glassware |
|-------------|----------------|----------------------------|
| M1250-9920 | XX | Universal Platform* |
| M1191-9908 | 108 | 50mL Erlenmeyer Flask |
| M1191-9909 | 60 | 125mL Erlenmeyer Flask |
| M1191-9910 | 40 | 250/300mL Erlenmeyer Flask |
| M1191-9911 | 24 | 500mL Erlenmeyer Flask |
| AG-1 | 15 | 1L Erlenmeyer Flask |
| AG-2 | 12 | 2L Erlenmeyer Flask |
| AG-00 | XX | Utility Tray |
| AG-4 | 6 | 4L Erlenmeyer Flask |
| AG-6 | 4 | 6L Erlenmeyer Flask |
| AG-28 | 6 | 2800mL Erlenmeyer Flask |

*Flask clamps must be ordered separately.

7.2 *Test Tube Racks for Universal Platform*

Test tube racks must be used on the Universal Platform (part number M1250-9920). The following choices are available:

| Catalog Number | Description | Tubes per Rack | Racks per Platform |
|----------------|------------------------------|----------------|--------------------|
| TTR-111 | Rack for 13 mm tubes | 48 | 7 |
| TTR-121 | Rack for 20 mm tubes | 33 | 7 |
| TTR-122 | Rack for 25 mm tubes | 21 | 7 |
| TTR-199 | Adjustable-angle slant rack | 15 | 4 |
| TTR-208 | Rack for 30 mm (50 mL) tubes | 15 | 7 |

7.3 **Accessory Flask Clamps**

All of the following clamps are constructed of stainless steel.

| Catalog Number | Type of Clamp |
|-----------------------|---|
| ACE-10S | 10mL Erlenmeyer |
| M1190-9004 | 25mL Erlenmeyer |
| M1190-9000 | 50mL Erlenmeyer, with spring retainer |
| M1190-9001 | 125mL Erlenmeyer, with spring retainer |
| M1190-9002 | 250mL Erlenmeyer, with spring retainer |
| M1190-9003 | 500mL Erlenmeyer, with spring retainer |
| ACE-1000S | 1.0L Erlenmeyer, with spring retainer |
| ACE-2000S | 2.0L Erlenmeyer, with spring retainer |
| ACE-4000S | 4.0L Erlenmeyer, with spring retainer |
| ACE-6000S | 6.0L Erlenmeyer, with spring retainer |
| ACFE-2800S | 2800mL Fernbach Flask, with spring retainer |
| ACSB-500S | 500mL Media Bottle, with spring retainer |
| ACSB-1000S | 1.0L Media Bottle, with spring retainer |

7.4 **Easy-Load Platform Option**

This easy-load accessory, also called a Quick-Change Platform, enables the user to snap in platforms without tools or hardware. The kit includes a subplatform with spring clips, extra counterweight and hardware. The kit does not include a platform.

Once it is installed, a speed range of 25-400 rpm is recommended.







The package should be installed by a qualified service engineer.

| Catalog Number | Description |
|-----------------------|--------------------|
| M1193-9931 | Easy-Loading Kit |





7.5 **Clamp Mounting Hardware Kit**

NBS Flask Clamps are used on a variety of shaker platforms. Flat head screws of different lengths and thread pitch are used to secure the clamp. The table below identifies the proper screw for your shaker application by reference to the head style.

HARDWARE FOR 10 mL TO 500 mL CLAMPS

| Description | Part Number | Qty. | Application |
|---|--------------------|-------------|--|
|  10-24 x 5/8 (15.87 mm) flat Phillips (+) head screw | S2116-3101 | 1 | 3/4" (19.05 mm) thick wood platform  |
|  10-24 x 5/16 (7.9 mm) flat Phillips (+) head screw | S2116-3051 | 1 | 5/16" (7.9 mm) thick aluminum, phenolic and stainless steel platforms.  |
|  10-32 x 5/16 (7.9 mm) flat slotted (-) head screw | S2117-3050 | 1 | all stainless steel platforms  |

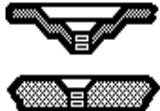
HARDWARE FOR 1-LITER TO 6-LITER CLAMPS

| Description | Part Number | Qty. | Application |
|---|--------------------|-------------|---|
|  10-24 x 5/8 (15.87 mm) flat Phillips (+) head screw | S2116-3101 | 5 | 3/4" (19.05 mm) thick wood platform  |
|  10-24 x 5/16 (7.9 mm) flat Phillips (+) head screw | S2116-3051 | 5 | 5/16" (7.9 mm) thick aluminum, phenolic and stainless steel platforms.  |
|  10-32 x 5/16 (7.9 mm) flat slotted (-) head screw | S2117-3050 | 5 | all stainless steel platforms  |



NOTE: 2800 mL Fernbach Flask Clamp applicable to above chart.

THIS PAGE INTENTIONALLY BLANK

8 DRAWINGS

8.1 Control Schematic

Figure 13: Control Schematic, Overview

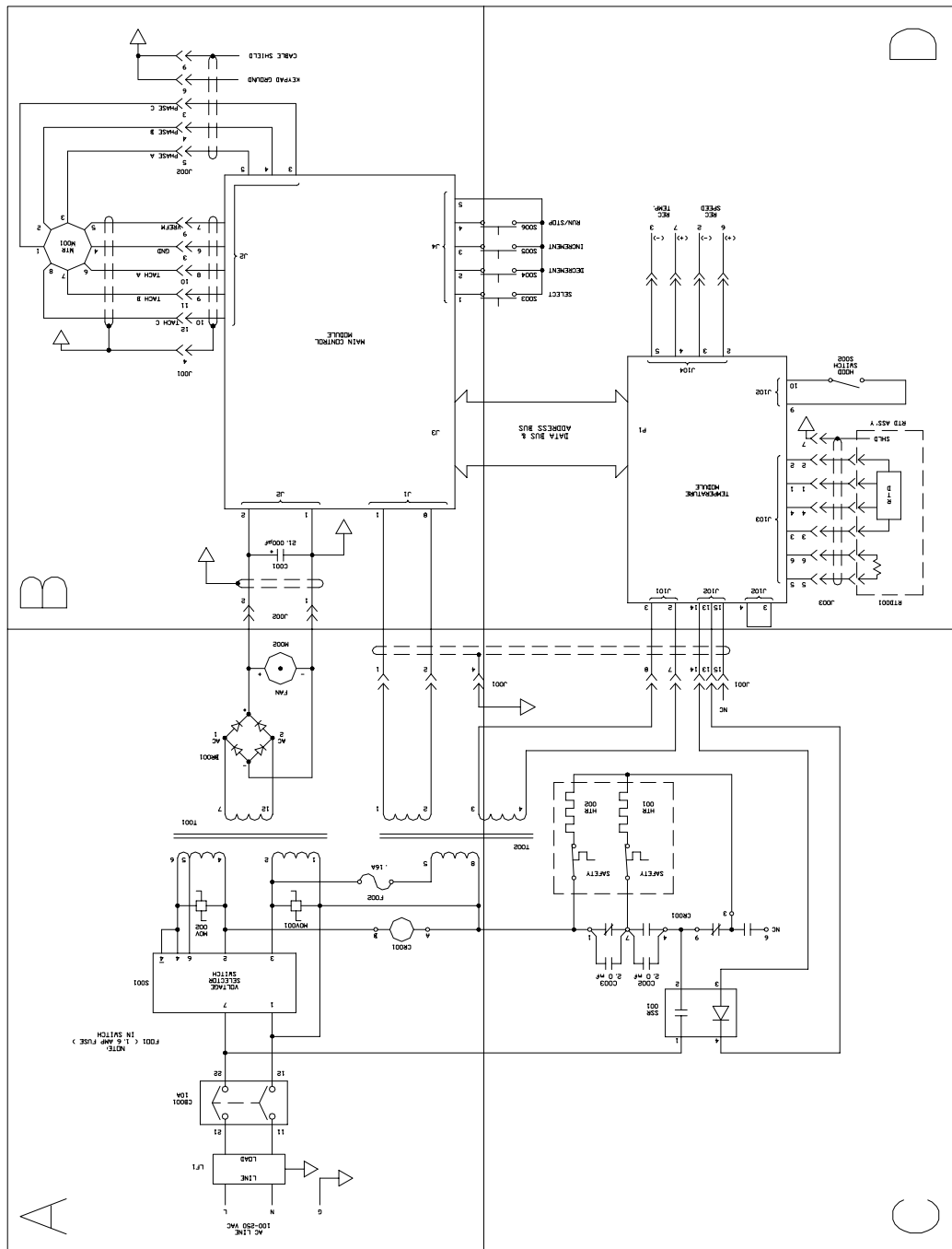

Figure 14: Control Schematic, Quadrant A

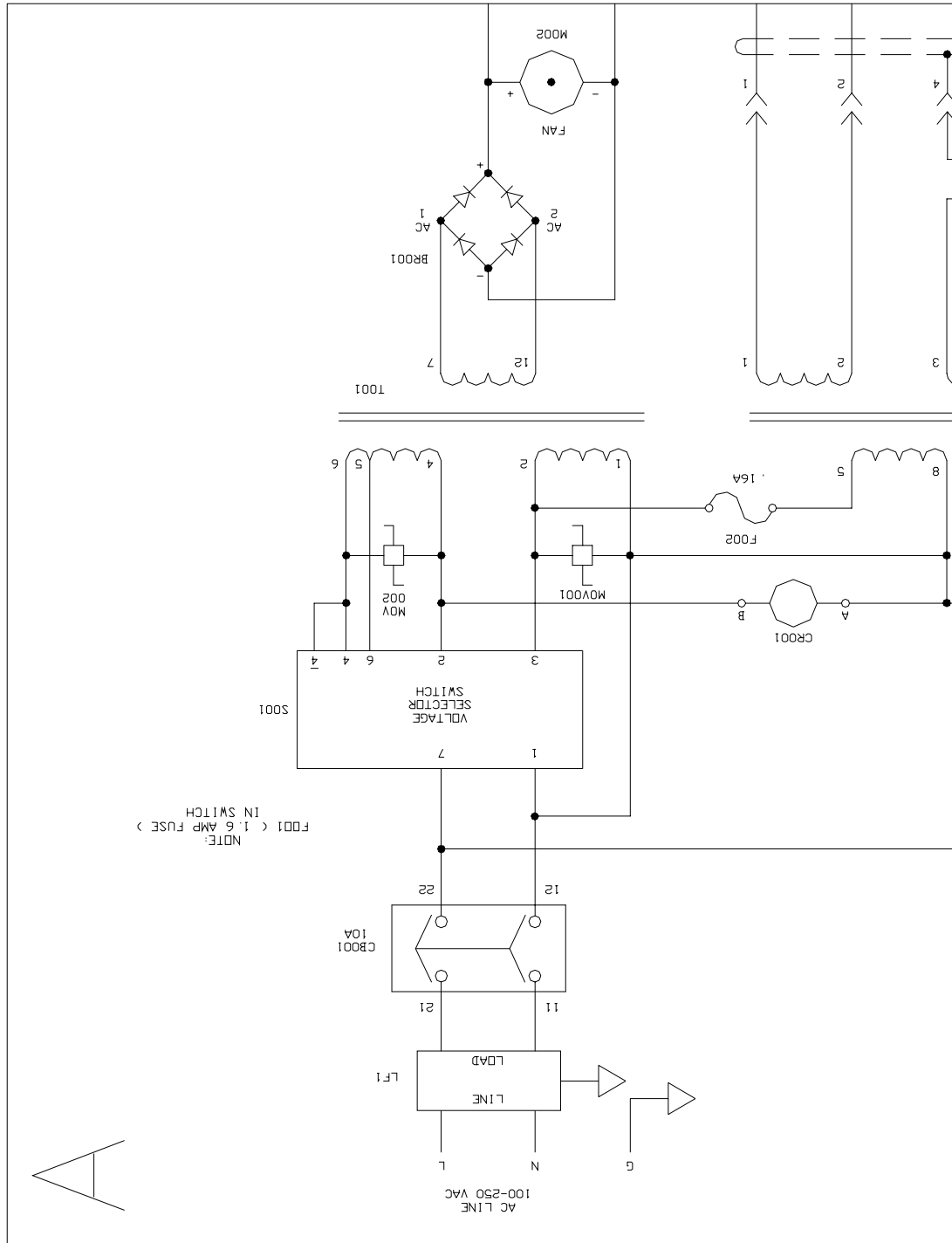

Figure 15: Control Schematic, Quadrant B

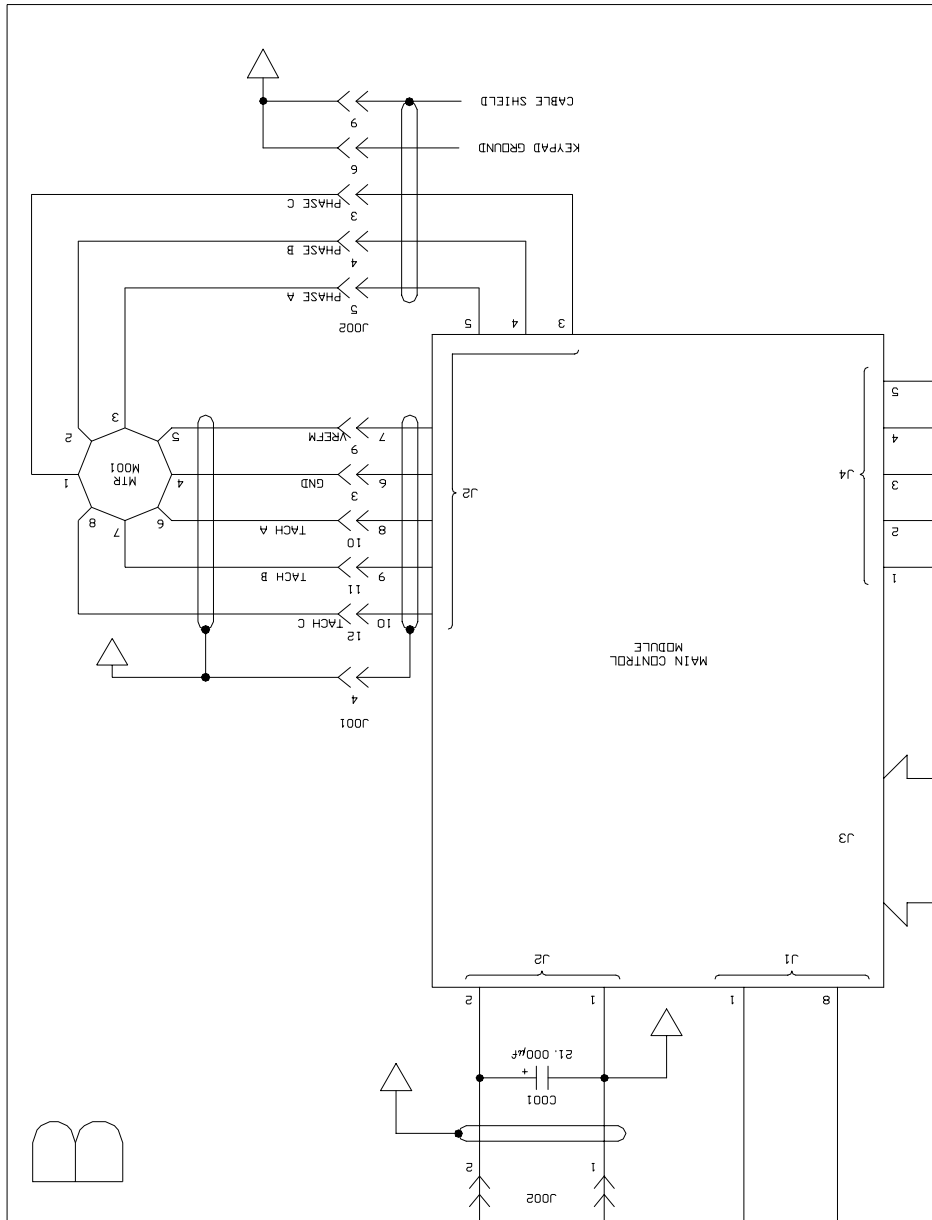
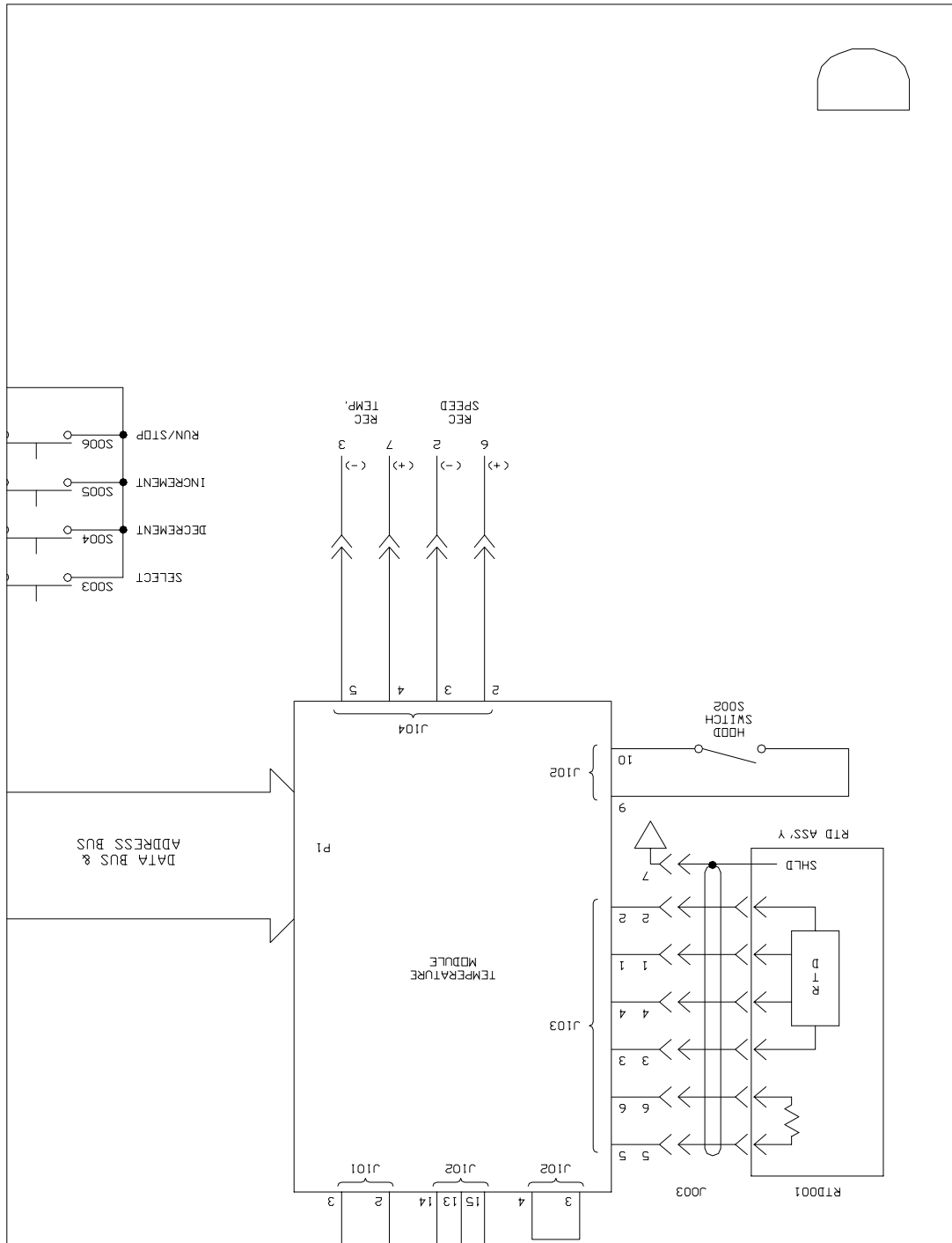

Figure 17: Control Schematic, Quadrant D



8.2 *Index of Drawings*

| Figure | Description | Page |
|---------------|--|-------------|
| 1 | Front View | 4 |
| 2 | Rear View | 4 |
| 3 | Side View | 5 |
| 4 | Control Panel | 7 |
| 5 | Counterbalanced Drive Mechanism | 9 |
| 6 | Space Requirements | 13 |
| 7 | 2- to 6-Liter Flask Clamp Installation | 15 |
| 8 | Belt Replacement & Adjustment | 25 |
| 9 | Motor Assembly Replacement | 26 |
| 10 | Recorder Connector | 28 |
| 11 | Control Board Replacement | 29 |
| 12 | Quick Change Platform Option | 33 |
| 13-17 | Control Schematics | 41-45 |

9 INDEX

- #**
- °C Indicator, 8
- A**
- Accessories, 37
 Accessory Flask Clamps, 38
 Accumulated Running Time, 22
 Actual Temperature, 21
 Alarm Functions, 19
 Alarms, 3, 19, 35
 Deactivating the, 19
 Reactivating the, 19
 Ambient Operating Environment, 35
 Audible Alarm, 19
 Automatic Drive, 36
 Automatic Restart Features, 36
- B**
- Bearings, 9
 Belt
 Adjusting the, 25
 Replacing the, 25
 Belt Tension
 Adjusting the, 25
 Checking the, 25
- C**
- Cancelling Timer, 19
 CAUTION
 Symbol for, vii
 Changing Fuses, 24
 Changing Voltage, 24
 Chart Recorder, 3, 35
 Clamp Mounting Hardware, 38
 Clamp Mounting Hardware Application Charts, 15, 38
 Clamps, 38
 Cleaning Instructions, 23
 Construction Features, 36
 Continuous Run, 17
 Control Panel, 6, 7
 Control Schematics, 45
 Copyright Notice, vii
 Counterbalanced Drive, 8, 9
- D**
- Deactivate Temperature Offset Calibration, 21
 Deactivating Alarms, 19
 Deactivating Temperature Control, 20
 Dimensions, 3, 12
- Chamber, 36
 Outside, 36
 Platform, 36
 Disclaimer Notice, vii
 Down ▽ Key, 6
 Drawings, 46
 Index of, 46
 Drive Mechanism, 8, 9, 35
- E**
- Easy-Load Platform, 38
 Electrical Connections, 13
 Electrical Service, 36
 Electronic Boards, 10
 Electrostatic Discharge, 28
 ESD Precautions, 28
 Exhaust Vent, 22
- F**
- Feet
 Adjusting the, 12
 Flashing °C Light, 21
 Flashing Display, 17
 Flask Clamps, 38
 Installation of, 14
 Foot Pedal, 3, 5
 Front View, 4
 Function Indicators, 6, 8
 Fuses, 5
 Changing the, 24
- H**
- Heater Description, 35
 HOURS Indicator, 8
 Hours Remaining
 Display of, 6
 How to Cancel Timer, 19
 How to Deactivate Temperature Control, 20
 How to Set Timer, 18
 How to Start, 17
 How to Work Alarms, 19
- I**
- Indicated Temperature, 21
 Inspection Instructions, 11
 Installation Instructions, 11
 International Offices
 List of, iii
 Interrupt Feature, 36

-
- K**
- Keypad, 6
- L**
- LED Display, 6
 - Flashing of, 17
 - Leveling Feet, 12
 - Leveling the Unit, 12
 - LID
 - Display of, 6
 - LID Display, 17
- M**
- Main Control Board, 10
 - Replacing the, 29
 - MAINT Indicator, 7, 22, 23, 27
 - Deactivation of, 22
 - Maintenance Instructions, 23
 - Manual Conventions, vii
 - Missing Parts, 11
 - Motor, 9, 36
 - Motor Assembly
 - Replacing the, 26
 - Motor Drive Belt
 - Adjusting the, 25
 - Replacing the, 25
 - MUTE Indicator, 7
- N**
- NOTE
 - Symbol for, vii
- O**
- ON/OFF Switch, 17
 - Operating Hours, 22
 - Operator Interface, 6
- P**
- Pedal, 3
 - Platforms, 37
 - Installation of, 14
 - Power Entry Module, 24
 - Precautions
 - about Cleaning, 23
 - about Electronic Boards, 28
 - about Electrostatic Discharge, 28
 - about Maintenance, 23
 - about Service, 23
 - for Electrical Connections, 13
- Q**
- Quick-Change Platform, 14, 32, 38
 - Installing the, 32
- R**
- Maximum Speed for, 14, 33
 - Removing the, 33
 - Quick-Change Platform Kit, 8
- S**
- Reactivating Alarms, 19
 - Rear View, 4
 - Recorder Adaptation, 27
 - Recorder Connector, 28
 - Recorder Pinout Diagram, 28
 - Recording Speed Data, 27
 - Recording Temperature Data, 27
 - Remote Monitoring, 35
 - RPM Indicator, 8
- T**
- SELECT Key, 6
 - Self-Diagnostic Status, 35
 - Service Parts, 34
 - SET Indicator, 7
 - Setpoints
 - Changing the, 18
 - Checking the, 18
 - Display of, 6
 - Setting the Temperature, 20
 - Set-Up Instructions, 11
 - Shaker Status, 6
 - Shaking
 - Starting, 17
 - Stopping, 17
 - Shaking Accuracy, 35
 - Shaking Indication, 35
 - Shaking Motion, 35
 - Shaking Setpoint & Control, 35
 - Shaking Speed, 6, 35
 - Shipping Damage, 11
 - Side View, 5
 - Space Requirements, 12
 - Specifications, 3, 35
 - Start/Stop Key, 6
 - Starting the Unit, 17
 - Status Indicator XE "TIME Indicator" s, 7
 - Status Indicators, 6
- T**
- Table of Contents, xi
 - Temperature
 - Display of, 6
 - Temperature Accuracy, 35
 - Temperature Control, 19
 - Deactivating the, 20
 - Temperature Control Board, 10
 - Replacing the, 31
 - Temperature Control Stability, 35
 - Temperature Correction Value, 21
 - Temperature Indicator, 8
 - Temperature Offset Calibration, 21

Temperature Range, 3, 19, 35
Temperature Safety Feature, 35
Temperature Setpoint, 35
Temperature Uniformity, 35
Test Tube Racks, 37
TIME Indicator, 7
Timed Functions, 18
Timer, 3
 Cancelling the, 19
 Features of, 35
 Setting the, 18
Total Running Time, 22
Triple Eccentric Drive, 8

U

Universal Power Capability, 5
Unlimited Run, 17
Unpacking Instructions, 11
Up Δ Key, 6

V

Vent, 5, 22
Visible Alarm, 19
Voltage Configuration, 11
Voltage Configuration Table, 11
Voltage Selector Switch, 5, 24
Voltage Setting, 5, 11, 24

W

WARNING
 Symbol for, vii
Warranty, ix
Weight
 Gross, 36
 Net, 36